

MOUNT WITH (2) 6-32 x $\frac{3}{8}$ PHILLIPS SCREW #101-0244
 (BLACK NICKEL) AND (2) NYLON WASHER #103-0069.

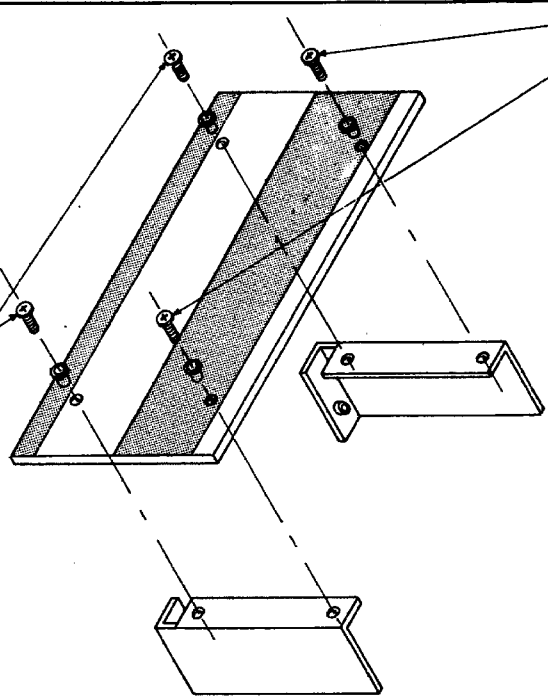

MOUNT WITH (2) 6-32 x $\frac{3}{8}$ PHILLIPS SCREW #101-0156
 (CADMIUM PLATED) AND (2) NYLON WASHER #103-0069.

PANEL ASSEMBLY

NOTE

1. PANELS: MAT'L. ALUMINUM ALLOY 1/8 THICK.
 FINISH: LIGHT GRAY PER FEDERAL STD. 595
 COLOR # 26440. ONE SIDE IS ADDITIONALLY
 TRIMMED DARK CHARCOAL GRAY SIMILAR
 TO HARTIN 6406.
2. MOUNTING BRACKETS: MAT'L. 16 GA COLD ROLLED STEEL
 FINISH: CADMIUM PLATED WITH A YELLOW
 CHROMATE WASH.

REVISIONS	DRAWN	CHKD.	APPR.	DATE

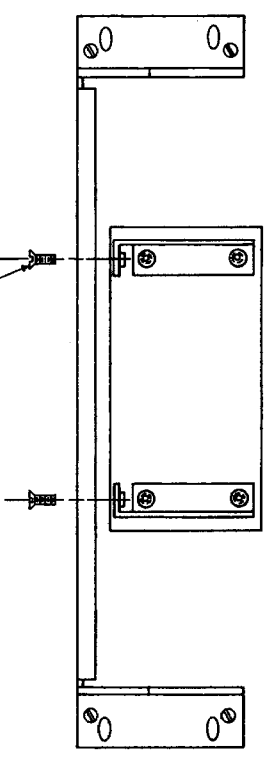

MOUNT WITH (2) 8-32 x $\frac{1}{2}$ FLAT HEAD SCREW
 #101-0027

RACK ADAPTER ASSEMBLY (REAR)

INSTALLATION INSTRUCTIONS

MODELS: RFP 24-1, RFP 24-2 and
 RFP 24-3

228-0514

TOLERANCE UNLESS OTHERWISE SPECIFIED: FRACTIONS ± 1/64 DECIMALS ± .005 ANGLES ± 1/2°