

OPERATOR'S MANUAL

MST SERIES POWER MODULE

DIGITALLY CONTROLLED POWER MODULE SYSTEM

1/9 RACK SIZE 200 WATT POWER MODULES FOR USE WITH KEPCO POWER MODULE CONTROLLERS

KEPCO INC.
An ISO 9001 Company.

MODELS



**MST 6-20M(F), MST 15-12M(F),
MST 25-8M(F), MST 36-5M(F),
MST 55-3.5M(F), MST 75-2.5M(F),
MST 100-2M(F), MST 150-1.2M(F)**

IMPORTANT NOTES:

- 1) This manual is valid for the following Model and associated serial numbers:

MODEL	SERIAL NO.	REV. NO.
-------	------------	----------

- 2) A Change Page may be included at the end of the manual. All applicable changes and revision number changes are documented with reference to the equipment serial numbers. Before using this Instruction Manual, check your equipment serial number to identify your model. If in doubt, contact your nearest Kepco Representative, or the Kepco Documentation Office in New York, (718) 461-7000, requesting the correct revision for your particular model and serial number.
- 3) The contents of this manual are protected by copyright. Reproduction of any part can be made only with the specific written permission of Kepco, Inc.

Data subject to change without notice.

©2019, KEPCO, INC
P/N 228-1736 REV 4



KEPCO, INC. ● 131-38 SANFORD AVENUE ● FLUSHING, NY. 11355 U.S.A. ● TEL (718) 461-7000 ● FAX (718) 767-1102
email: hq@kepcopower.com ● World Wide Web: <http://www.kepcopower.com>

Conditions of Conformance MST “Modular” products

When this product is used in applications governed by the requirements of the EEC, the following restrictions and conditions apply:

1. For European applications, requiring compliance to the Low Voltage Directive, 73/23/EEC, this power supply is considered a component product, designed for “built in” applications. Because it is incomplete in construction, the end product enclosure must provide for compliance to any remaining electrical safety requirements and act as a fire enclosure. (EN61010-1:2001 Cl. 6, Cl. 7, Cl.8, and Cl. 9)
2. This power supply is designed for stationary installation, with mains power applied via a KEPCO Rack Adapter.
3. This power supply is considered a Class 1 (earthed) product. It is intended for use as part of equipment meant for test, measurement and laboratory use, and is designed to operate from single phase, three wire power systems. This equipment must be installed in a specifically designed KEPCO rack adapter and within a suitably wired equipment rack, utilizing a three wire (grounded) mains connection. See wiring section of this manual for complete electrical wiring instructions. (EN61010-1:2001 Cl.6.10.1)
4. This power supply has secondary output circuits that are considered hazardous.
5. The output wiring terminals of this power supply have not been evaluated for field wiring and, therefore, must be properly configured by the end product manufacturer prior to use.
6. This power supply employs a supplementary circuit protector in the form of a fuse mounted within its enclosure. The fuse protects the power supply itself from damage in the event of a fault condition. For complete circuit protection of the end product, as well as the building wiring, it is required that a primary circuit protection device be fitted to the branch circuit wiring. (EN61010-1:2001 Cl. 9.5)
7. Hazardous voltages are present within this power supply during normal operation. All operator adjustments to the product are made via externally accessible switches, controls and signal lines as specified within the product operating instructions. There are no user or operator serviceable parts within the product enclosure. Refer all servicing to qualified and trained Kepco service technicians.

SAFETY INSTRUCTIONS

1. Installation, Operation and Service Precautions

This product is designed for use in accordance with EN 61010-1 and UL 3101 for Installation Category 2, Pollution Degree 2. Hazardous voltages are present within this product during normal operation. This product is designed for use in a KEPCO Rack Adapter product. Operation of this product without a rack adapter should never be attempted. The product should never be operated with the cover removed unless equivalent protection of the operator from accidental contact with hazardous internal voltages is provided.



There are no operator serviceable parts or adjustments within the product enclosure. Refer all servicing to trained service technician.



Source power must be removed from the product prior to performing any servicing.



This product is designed for use with nominal a-c mains voltages indicated on the rating nameplate.

2. Grounding

This product is a Class 1 device which utilizes protective earthing to ensure operator safety.



The PROTECTIVE EARTHING CONDUCTOR TERMINAL must be properly connected prior to application of source power to the product (see instructions on installation herein) in order to ensure safety from electric shock.



PROTECTIVE EARTHING CONDUCTOR TERMINAL - This symbol indicates the point on the product to which the protective earthing conductor must be attached.



EARTH (GROUND) TERMINAL - This symbol is used to indicate a point which is connected to the PROTECTIVE EARTHING TERMINAL. The component installer/ assembler must ensure that this point is connected to the PROTECTIVE EARTHING TERMINAL.

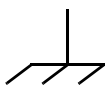

CHASSIS TERMINAL - This symbol indicates frame (chassis) connection, which is supplied as a point of convenience for performance purposes (see instructions on grounding herein). This is not to be confused with the protective earthing point, and may not be used in place of it.

3. Electric Shock Hazards

This product outputs hazardous voltage and energy levels as a function of normal operation. Operators must be trained in its use and exercise caution as well as common sense during use to prevent accidental shock.



This symbol appears adjacent to any external terminals at which hazardous voltage levels as high as 500V d-c may exist in the course of normal or single fault conditions.



This symbol appears adjacent to any external terminals at which hazardous voltage levels in excess of 500V d-c may exist in the course of normal or single fault conditions.

TABLE OF CONTENTS

SECTION	PAGE
SECTION 1 - INTRODUCTION	
1.1	Scope of Manual 1-1
1.2	Description 1-1
1.3	Specifications 1-1
1.4	Features 1-3
1.4.1	Control/Programming..... 1-3
1.4.2	Status Indicators..... 1-6
1.4.3	Front Panel Meters 1-6
1.4.4	Output Enable/Disable and Polarity Reversal..... 1-6
1.4.5	Protection..... 1-6
1.4.6	Series Configurations 1-6
1.4.7	Parallel Configuration 1-7
1.5	Options 1-7
1.6	Accessories 1-7
SECTION 2 - INSTALLATION	
2.1	Unpacking and Inspection 2-1
2.2	Terminations and Controls 2-1
2.3	A-C Input Requirement..... 2-1
2.4	Cooling 2-1
2.5	Preliminary Check-out 2-3
2.5.1	Required Equipment..... 2-3
2.5.2	Initial Setup..... 2-3
2.5.3	Checkout Procedure..... 2-5
2.6	Installation/Removal 2-7
2.6.1	Changing Control Bus Address (Node or Channel Number)..... 2-7
2.6.2	Installation..... 2-9
2.6.3	Removal..... 2-10
2.7	Grounding..... 2-10
2.7.1	Safety Grounding..... 2-10
2.7.2	D-C (Output) Grounding 2-10
2.8	Power Module to Load Interface 2-11
2.9	Connection, General 2-12
2.9.1	Load Connection with Local Error Sensing..... 2-13
2.9.2	Load Connection with Remote Error Sensing..... 2-13
SECTION 3 - OPERATION	
3.1	Introduction to Controlling the MST Power Module Output 3-1
3.1.1	Status Flags (Error Messages)..... 3-1
3.1.2	Timing Requirements for a Valid Status 3-1
3.2	Operating Modes..... 3-2
3.2.1	Voltage Mode..... 3-2
3.2.2	Current Mode..... 3-2
3.3	Output Polarity Reversal 3-2
3.4	Output Enable and Disable 3-4
3.5	Parallel Operation..... 3-5
3.6	Series Operation 3-5
3.7	Fault Protection 3-6
3.7.1	Fault Recovery..... 3-6
3.7.2	Tracking Overvoltage and Overcurrent Detectors 3-6
3.7.3	Overtemperature Detectors 3-7
3.7.4	A-C Loss Detector 3-7
3.7.5	Open Sense/Power Wire Protection..... 3-7
3.8	Calibration 3-8

TABLE OF CONTENTS

SECTION		PAGE
3.8.1	Equipment Required	3-8
3.8.2	+5 Volts Reference Adjust (R49)	3-9
3.8.3	Output Voltage (E_O) Zero Adjust (R11)	3-10
3.8.4	Current Sense Zero Adjust (R50)	3-10
3.8.5	Output Current I_O Zero Adjust (R51)	3-10
3.8.6	Voltage Reference Adjust (R47)	3-11
3.8.7	Current Reference Adjust (R48)	3-11
3.8.8	Current (I_O) Full Scale Adjust (R52)	3-11

LIST OF FIGURES

FIGURE	TITLE	PAGE
1-1	MST Power Supply	iv
1-2	MST Power Supply, Mechanical Outline Drawing	1-4
1-3	Remotely Controlled Power Supply Configurations Using Kepco Products	1-5
2-1	Front and Rear Views of the MST Power Module.....	2-2
2-2	DC Output Connector Configuration for Preliminary Checkout.....	2-3
2-3	Initial Checkout Setup	2-4
2-4	Configuration and Calibration Controls and Testpoints	2-9
2-5	Output Impedance vs. Frequency.....	2-11
2-6	Connector Locations and Pin Assignments	2-13
3-1	Calibration Test Set-up	3-9

LIST OF TABLES

TABLE	TITLE	PAGE
1-1	MST Model Parameters	1-1
1-2	MST General Specifications	1-2
1-3	Accessories	1-7
2-1	Functions of Internal Controls	2-1
2-2	Front Panel Controls and Indicators	2-2
2-3	Rear Terminations	2-3
2-4	Node Address Selection	2-8
2-5	DC Output Connector Pin Designations	2-12
3-1	Error Messages	3-1
3-2	Maximum External Capacitance Values to Ensure Dry Switching	3-3

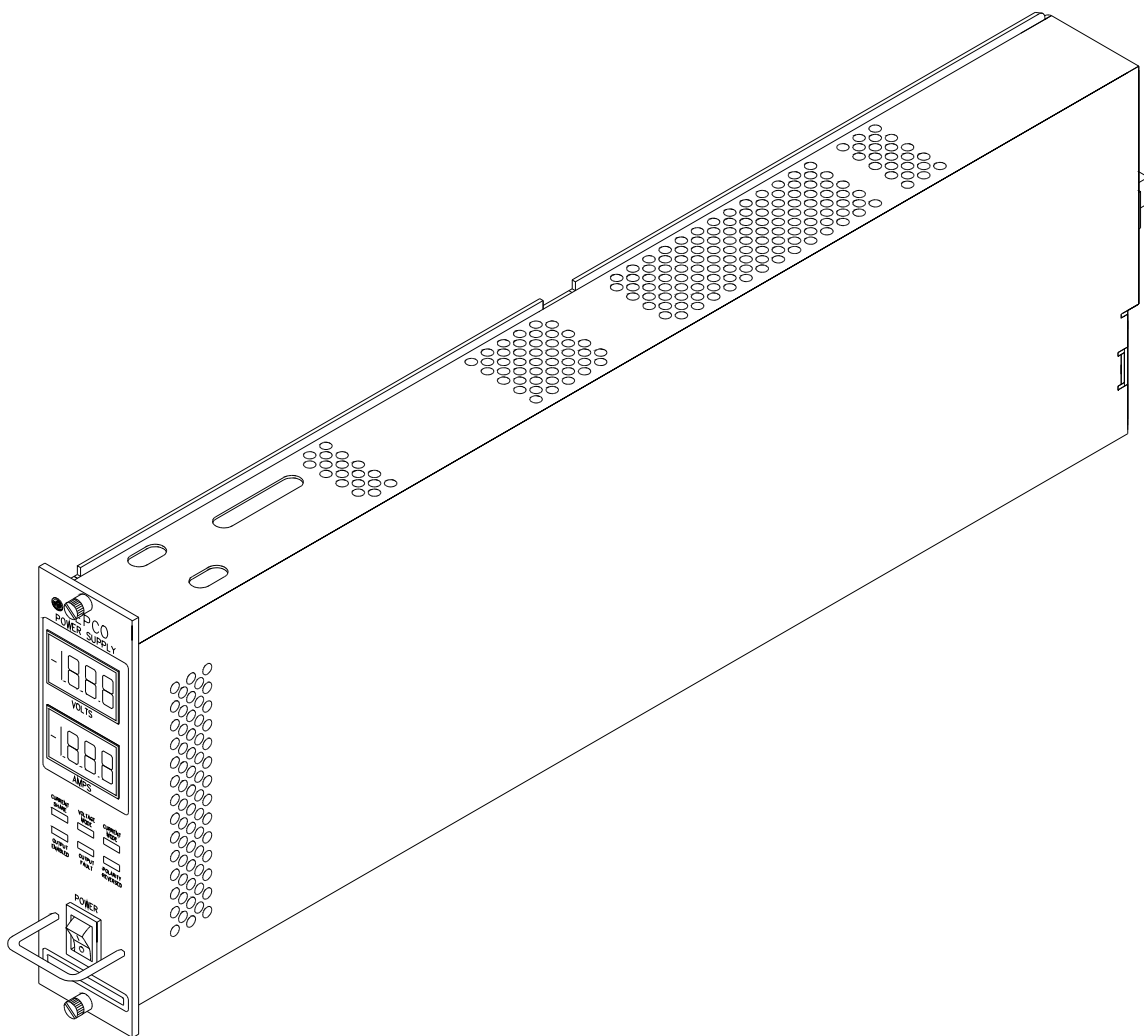

3041110

FIGURE 1-1. MST POWER SUPPLY

SECTION 1 - INTRODUCTION

1.1 SCOPE OF MANUAL

This manual contains instructions for the installation, operation, and maintenance of the MST series of 200 Watt, voltage and current stabilized d-c power supplies (power modules) manufactured by Kepco, Inc., Flushing, New York, U.S.A.

1.2 DESCRIPTION

The Kepco MST 200 Watt Series (Figure 1-1) consists of eight, single-output models as shown in Table 1-1. MST Series Power Modules employ a switch mode preregulator for high efficiency and power density, with linear output stabilization for accuracy and resolution. MST Power Supplies (Modules) are of a modular, plug-in design whose 7" x 1-3/4" cross-section allows nine independently controlled modules to be mounted abreast in a standard (19" x 7" x 20.9") Kepco Model RA 55 rack adapter or 5 modules in a standard (9.6" x 7" x 20.9") Kepco Model CA 400 case.

The MST Power Module is controlled digitally via the IEEE 1118 2-wire serial bus ("Bitbus") with 12 bits of resolution over the entire voltage and current ranges. Voltage and current are displayed on LED panel meters, and read back over the control bus with an accuracy of 0.06%. Operating status is displayed on front panel LED indicators and read back over the bus.

An MST Power Module can be removed and installed without powering down the system if the module POWER switch is set to OFF. Employing current-sharing for parallel operation, they may be "hot-swapped" for redundant (N+1) applications. MST Power Supplies can be operated with universal a-c input power sources (90-264Vac, 47-63Hz) and incorporate power factor correction (0.98) to meet EN 61000-3-2. MST Power Modules can also be configured in series for higher than rated output voltages (500V d-c maximum).

TABLE 1-1. MST MODEL PARAMETERS

MODEL	OUTPUT VOLTAGE Adjustment Range (V d-c)	OUTPUT CURRENT Maximum (Amps)			RIPPLE (mV p-p)		NOISE (mV p-p)	EFFICIENCY (100% Load 120V a-c)
		45° C	55° C	65° C	Source (max.)	SW (max.)	(Spike) 20MHz	
MST 6-20M	0-6	20	16	12	2.5	5	50	51%
MST 15-12M	0-15	12	9.6	7.2	5	10	100	61%
MST 25-8M	0-25	8	6.4	4.8	5	10	100	62%
MST 36-5M	0-36	5	4.0	3.0	5	10	100	63%
MST 55-3.5M	0-55	3.5	2.8	2.1	5	10	100	64%
MST 75.2.5M	0-75	2.5	2.0	1.5	7.5	15	150	64%
MST 100-2M	0-100	2.0	1.6	1.2	7.5	15	150	66%
MST 150-1.2M	0-150	1.2	1.0	0.7	7.5	20	200	66%

1.3 SPECIFICATIONS

The MST Series electrical and mechanical specifications are listed in Tables 1-1 and 1-2.

TABLE 1-2. MST GENERAL SPECIFICATIONS

SPECIFICATIONS		RATING/DESCRIPTION	CONDITION
INPUT			
A-C Voltage	nominal	100-250V a-c	Single phase
	range	90-264 Va-c	Brownout Voltage \leq 85Vrms
Frequency	nominal	50-60 Hz	At >63 Hz, input leakage current exceeds specifications
	range	47 – 63 Hz (400 Hz)	
Input Current	maximum	3.6A rms	90V a-c Input
Current Harmonics		Within EN 61000-3-2 limits	Any source condition, rated load
Efficiency	minimum	See Model Table 1-1	120V a-c, rated output Load
EMI		FCC Class A, CISPR 11 Class A	Conducted Emissions
Leakage Current	120V a-c, 60Hz	<0.5 mA	
	240V a-c, 50Hz	<1.0 mA	
Power Factor		0.98 min.	All source conditions, full load
EMC		Complies with IEC 61326-1, Class A	
OUTPUT			
Source Effect	Voltage	0.001%	90 – 132, 176 – 264V a-c, any load condition
	Current	0.005%	
Load Effect	Voltage	\pm 0.002% or 0.5mV, whichever is greater	10% to 100% Load at E_{MAX} , any source condition
	Current	\pm 0.005% ⁽¹⁾	10% to 100% Load at I_{MAX}
Temperature Effect	Voltage	0.01%/°C	Any source/load condition (0 – 45° C)
	Current	0.02%/°C	
Time Effect (drift)	Voltage	0.01%	0.5 – 8.5 hours Any source/load condition
	Current	0.02%	
Programming Resolution	Voltage	12 Bits, 0.024%	% of E_{MAX}
	Current	12 Bits, 0.024%	% of I_{MAX}
Data Read Back Accuracy	Voltage	0.1%	% of E_{MAX}
	Current	0.12%	% of I_{MAX}
Transient Recovery Time		100 Microseconds (500 Microseconds for MST 6-20M)	Return to within stabilization band from 50% load step
Turn On/Off Overshoot		None	Any source/load condition
Error Sense		0.5V maximum/wire	Any source/load condition
MISCELLANEOUS			
Temperature		0° to +65° C, start from –20°C (see Table 1-1)	Operating
		–40° to +85° C	Storage
Humidity		0 to 95% RH	Non-condensing Operating & Storage
Shock		20G 11 msec \pm 50% half sine	3 axes, 3 shocks each axis, non-operating
Vibration		5 – 10Hz 10mm double amplitude	Non-operating, 1 hour each axis
		10 – 55 Hz 2G	
Altitude		Sea level to 10,000 ft.	Any source/load condition
Isolation (Output – Case)		\pm 500 V d-c	
Display	Voltage	3.5 Digit LED, red	Front panel, For reference only
	Current	3.5 Digit LED, red	
(1) Current mode regulation is subject to an additional 0.015% settling effect as well as a d-c offset of up to 3mA based on compliance voltage			

TABLE 1-2. MST GENERAL SPECIFICATIONS (CONTINUED)

SPECIFICATIONS	RATING/DESCRIPTION		CONDITION
Status Indicators	Voltage Mode		Green LED
	Current Mode		Amber LED
	Current Share		Amber LED
	Output Enabled		Green LED
	Polarity Reversed		Green LED
	Output Fault		Red LED
Output Enable	Built in power and sense relay		
Polarity Reversal	Built in power and sense relay		
Parallel Connection	N+1 redundancy, forced current share		Currents divided equally
Overvoltage protection	Tracks output setting, power shutdown		Latched, reset by cycling source power off
Overtemperature	Thermostat		
Open sense wire	Automatic detection with power shutdown		
Backup current limit	Tracks output current at 110%		
PHYSICAL			
Type of Construction	Enclosed, plug-in style includes status LEDs, two digital meters, handle and ON/OFF switch		
Cooling	Internal D-C Cooling Fans		Exhaust to rear
Module Dimensions	English	7" x 1.83" x 20"	Refer to Figure 1-2
	Metric	178 x 46.5 x 508 mm	
Weight	English	8 lbs.	
	Metric	3.6 Kg.	
Load Connection	Mates with Positronic POW-R-LOK Series 6 pin connector, Kepco P/N 143-0458 (See Figure 2-6 and Table 2-5),		Mating connectors provided with MST compatible rack adapters
Source Connection	Mates with Molex Minifit, Jr. Series 10 pin connector, Kepco p/n 143-0544 (See Figure 2-6)		Mates with a-c backplane in MST compatible rack adapters

1.4 FEATURES

1.4.1 CONTROL/PROGRAMMING

Control of the MST Power Module is via the IEEE 1118 2-wire serial bus operating at 375KHz; as many as 27 separate modules of either the MST, MAT, MBT or BOP Series design can be addressed via the bus (see Figure 1-3). Decoders for RS232, IEEE-488 and VXI are available in modular form and stand-alone types. As shown in Figure 1-3, the following controllers are available to control of MST (and MAT) Power Modules directly from a computer.

- a. Controller Model TMA PC-27 plugs into a half-card slot of a DOS-based PC and allows keyboard control of the MST via the IEEE 1118 bus.
- b. Controller Model TMA 4882-27 is free-standing and allows host computers designed for RS232 or IEEE 488 bus communication to control the MST via the IEEE 1118 bus.
- c. Controller Model TMA-VXI-27 plugs into a slot in a VXI chassis and allows VXI-based computers to control the MST via the IEEE 1118 bus.
- d. Controller Model MST 488-27 plugs into a slot in a Model RA 55 Rack Adapter and allows host computers designed for RS232 or IEEE 488 bus communication to control the MST via the IEEE 1118 bus.
- e. The MST Power Module can also be directly controlled via the keypad of the MBT Series ("G" Option) Power Supply via the IEEE 1118 bus.

NOTES:

1. MATERIAL:
 - A) CHASSIS & COVER: 0.064 THK. ALUM. 5052-H32.
 - B) FRONT PANEL: 0.125 THK. ALUM. 6061-T6.
2. FINISH:
 - A) CHASSIS & COVER: YELLOW IRIDITE.
 - B) FRONT PANEL: KEPKO GRAY, HARTIN PAINT #15-22493.
3. DIMENSIONS IN PARENTHESES ARE IN MILLIMETERS.
4. TOLERANCES:
 - A) BETWEEN MOUNTING HOLES: $\pm 1/64(\pm 0.4)$.
 - B) ALL OTHER DIMENSIONS: $\pm 1/32(\pm 0.8)$ EXCEPT AS NOTED.

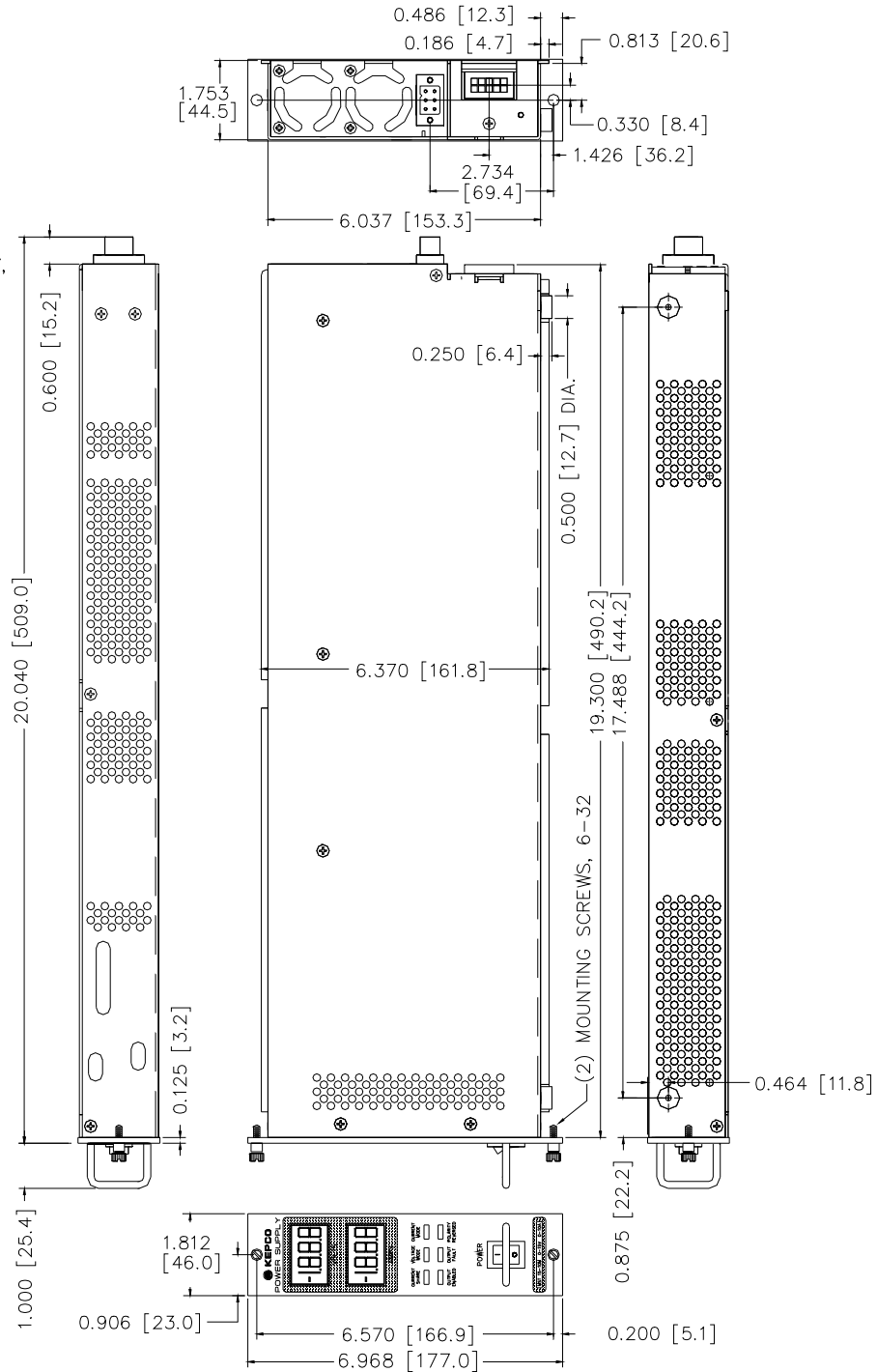

3040955

FIGURE 1-2. MST POWER SUPPLY, MECHANICAL OUTLINE DRAWING

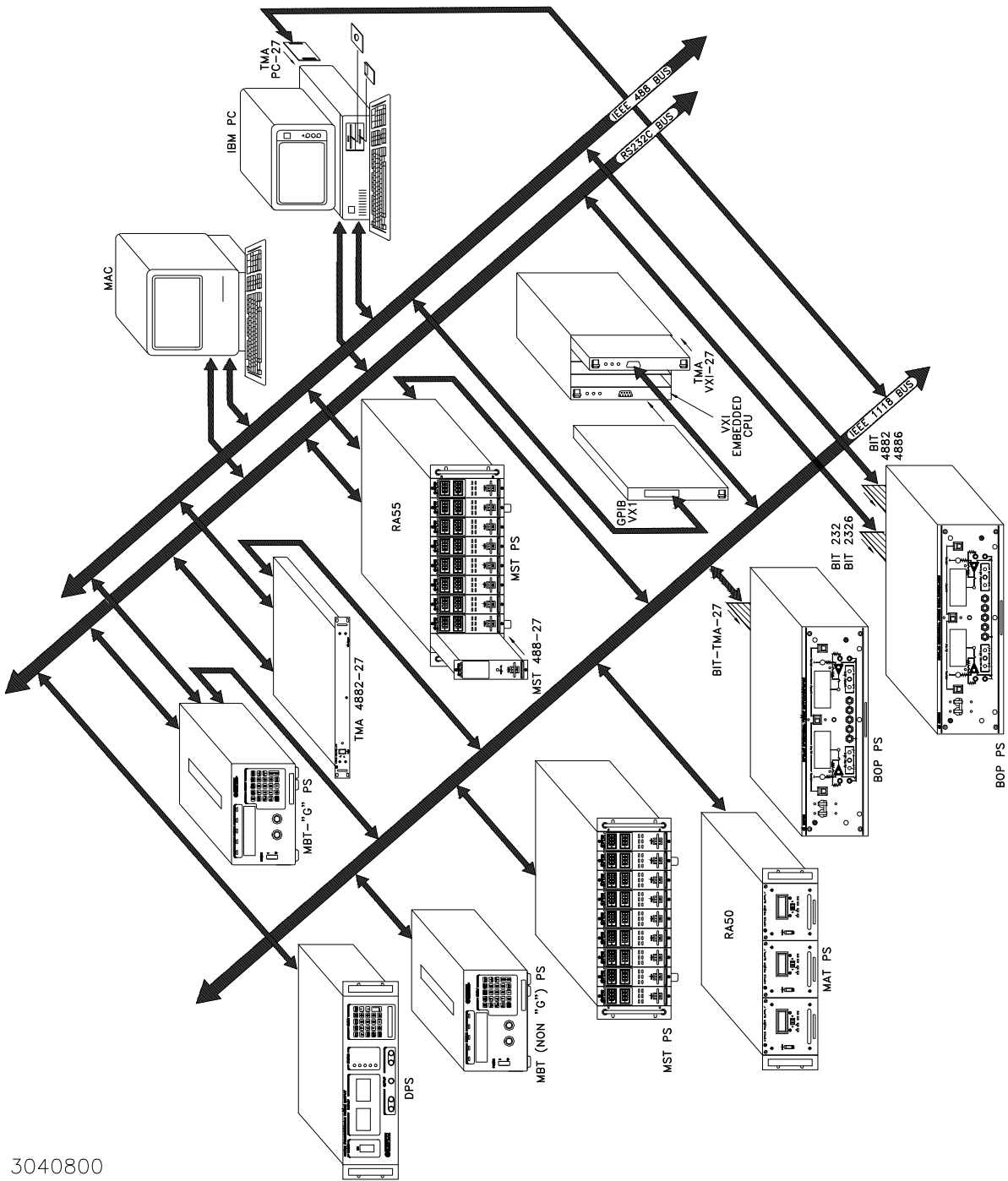

3040800

FIGURE 1-3. REMOTELY CONTROLLED POWER SUPPLY CONFIGURATIONS USING KEPCO PRODUCTS

1.4.2 STATUS INDICATORS

Six status indicators at the front panel provide operational information (see Table 2-2):

- VOLTAGE MODE
- CURRENT MODE
- CURRENT SHARE
- OUTPUT ENABLED
- POLARITY REVERSED
- OUTPUT FAULT

1.4.3 FRONT PANEL METERS

Two digital meters at the front panel provide displays of output voltage and current. These displays show 3.5 digits and are provided for reference only, accurate to 0.5% (typical) for voltage and 1.5% (typical) for current.

1.4.4 OUTPUT ENABLE/DISABLE AND POLARITY REVERSAL

The MST Power Module features integral relays to enable/disable the output and to allow polarity reversal. Separate relays are provided for power and sense connections. Disabling the MST as a voltage source means opening the connection between the power supply and its load. Disabling the MST as a current source means shorting the power supply's output terminals. The polarity reversal relays provide for two-quadrant operation.

1.4.5 PROTECTION

The MST Power Module incorporates the following protection circuits which cause the MST to automatically isolate the load and force power module output voltage and current to zero.

- Overvoltage protection: Tracks output voltage; activated if the output goes out of tolerance (see PAR. 3.7.2).
- Overcurrent protection: Tracks output current; activated if the output goes out of tolerance (see PAR. 3.7.2).
- Overtemperature: Activated when the internal temperature exceeds a safe operating threshold (see PAR. 3.7.3).
- AC loss: Activated if loss of source power detected (see PAR. 3.7.4).
- Open power lead and sense wire: Activated if an open sense wire or open power lead is detected (see PAR. 3.7.5).

1.4.6 SERIES CONFIGURATIONS

The output of the MST Power Module “floats;” so that MST Power Modules can be connected in series to obtain higher output voltages, up to a maximum of ± 500 Volts referenced to the chassis (see PAR. 3.6).

1.4.7 PARALLEL CONFIGURATION

A parallel configuration may be employed for higher output current and for N + 1 redundant, “hot-swap” applications. When connected in a parallel configuration, MST Power Modules employ forced current sharing to ensure equal distribution of the load among all power modules, improving performance, reducing component stress, and increasing reliability (see PAR. 3.5).

1.5 OPTIONS

The F option (F appended to the Model Number, e.g., MST 6-20MF) incorporates additional filtering to provide significant output noise reduction in the range of 1KHz to 10MHz. Contact Kepco Sales Engineering for additional information regarding performance and availability.

1.6 ACCESSORIES

The MST Power Module is designed for installation in Kepco Rack Adapter Model RA 55 which accommodates nine 1/9 rack size power modules. With a 1/9 rack Controller module installed, the RA55 will accommodate eight 1/9 rack power modules. Connecting cables and IEEE 1118 bus daisy chain terminations are supplied with the RA 55 Rack Adapter. Additional accessories are listed in Table 1-3.

TABLE 1-3. ACCESSORIES

ACCESSORY	PART NUMBER	USE
MATING CONNECTOR (DC OUTPUT)	142-0372	Mates with DC OUTPUT connector, Kepco P/N 143-0457 (Positronic POW-R-LOK Series 6 pin connector).
LOAD CONNECTOR PINS	107-0327	Replacement pins for DC OUTPUT connector.
LOAD CABLE	118-0849	Allows output load connections of up to 20 Amperes to MST power module not installed in RA 55 Rack Adapter (for advanced troubleshooting). Cable length is approximately 7 feet, terminated at one end with mating connector for MST module output connector. The opposite end is terminated with two hook lugs for the power connections, as well as a ring lug for the load sharing connection. Error sensing is established at the hook lug terminals. This cable is typically used in conjunction with 118-0850 Input Power/Communication Cable.
INPUT POWER/COMMUNICATION CABLE	118-0850	Allows power and communication connections to MST power module not installed in RA 55 Rack Adapter (for advanced troubleshooting). Cable length is approximately 7 feet, terminated at one end with mating connector for MST module a-c input/control bus connector. The opposite end of the cable is split into two terminations, one a NEMA 5-20P a-c mains plug and the other a 9-pin D-sub connector that mates with the control bus connector of RA 55 (as well as CA 400, MST 488-27 or TMA 4882-27). This cable is typically used in conjunction with 118-0849 Output Load Cable.

SECTION 2 - INSTALLATION

2.1 UNPACKING AND INSPECTION

This instrument has been thoroughly inspected and tested prior to packing and is ready for operation. After careful unpacking, inspect for shipping damage before attempting to operate. Perform the preliminary operational check as outlined in PAR. 2.5. If any indication of damage is found, file an immediate claim with the responsible transport service.

NOTE

If the Power Modules are shipped pre-installed in the RA 55 Rack Adapter, each module is secured to the RA 55 Rack Adapter by two shipping screws. These screws must be removed from the bottom of the rack adapter, otherwise the modules cannot be removed from the rack adapter.

2.2 TERMINATIONS AND CONTROLS

- a. Internal Calibration Controls: Refer to Figure 2-4 and Table 2-1.
- b. Front Panel: Refer to Figure 2-1 and Table 2-2.
- c. Rear Panel: Refer to Figure 2-1 and Table 2-3.

TABLE 2-1. FUNCTIONS OF INTERNAL CONTROLS

REFERENCE DESIGNATION	CONTROL	PURPOSE
R49	+5 V REF	This is a primary adjustment for the analog circuits.
R11	E_O Zero	This control is used to adjust the output voltage of the Power Module to zero. E_O Zero calibrates the Power Module in the Voltage mode.
R51	I_O Zero	This control is used to adjust the output current of the Power Module to zero. I_O Zero calibrates the Power Module in the Current mode.
R50	Current Sensing Zero	This adjustment calibrates the current monitor amplifier to zero.
R52	Full Scale Current Adjust	This adjustment calibrates the programmed full scale value.
R47	V_{REF}	This is a full scale voltage adjustment.
R48	I_{REF}	This is a current read back accuracy adjustment.

2.3 A-C INPUT REQUIREMENT

MST Power Modules operate from single-phase a-c mains power over the specified voltage and frequency ranges without adjustment or modification.

2.4 COOLING

The power transistors and rectifiers in the MST Power Module are maintained within their operating temperature range by means of internal heat sink assemblies cooled by internal fans. PANEL OPENINGS AND THE TOP OF THE CASE MUST BE KEPT CLEAR FROM OBSTRUCTIONS TO INSURE PROPER AIR CIRCULATION. Maximum ambient temperature for installed MST modules is 45°C. See technical manuals for RA 55 or CA 400 rack adapters

for detailed cooling requirements. Periodic cleaning of the power module interior is recommended.

TABLE 2-2. FRONT PANEL CONTROLS AND INDICATORS

CONTROL/INDICATOR	FUNCTION
POWER switch	Turns a-c power ON/OFF. CAUTION: DO NOT repeatedly toggle the POWER On/Off switch as this may cause unit to fault.
VOLTAGE MODE indicator - green LED	Goes on to indicate MST is operating as a voltage source (see PAR. 3.2.1).
CURRENT MODE indicator - amber LED	Goes on to indicate MST is operating as a current source (see PAR. 3.2.2).
POLARITY REVERSED indicator - green LED	Goes on when negative output programmed while the output is enabled.(see PAR. 3.3).
OUTPUT ENABLE indicator - green LED	Goes on to indicate power relays are closed and output regulator is enabled (see PAR. 3.4).
OUTPUT FAULT indicator - red LED	Goes on to indicate internal power module fault detected (see PAR. 3.7).
CURRENT SHARE indicator - amber LED	Goes on to indicate that unit is operating as “slave” module when used in a parallel configuration (see PAR. 3.5).
VOLTS meter	Displays output voltage.
AMPS meter	Displays output current.

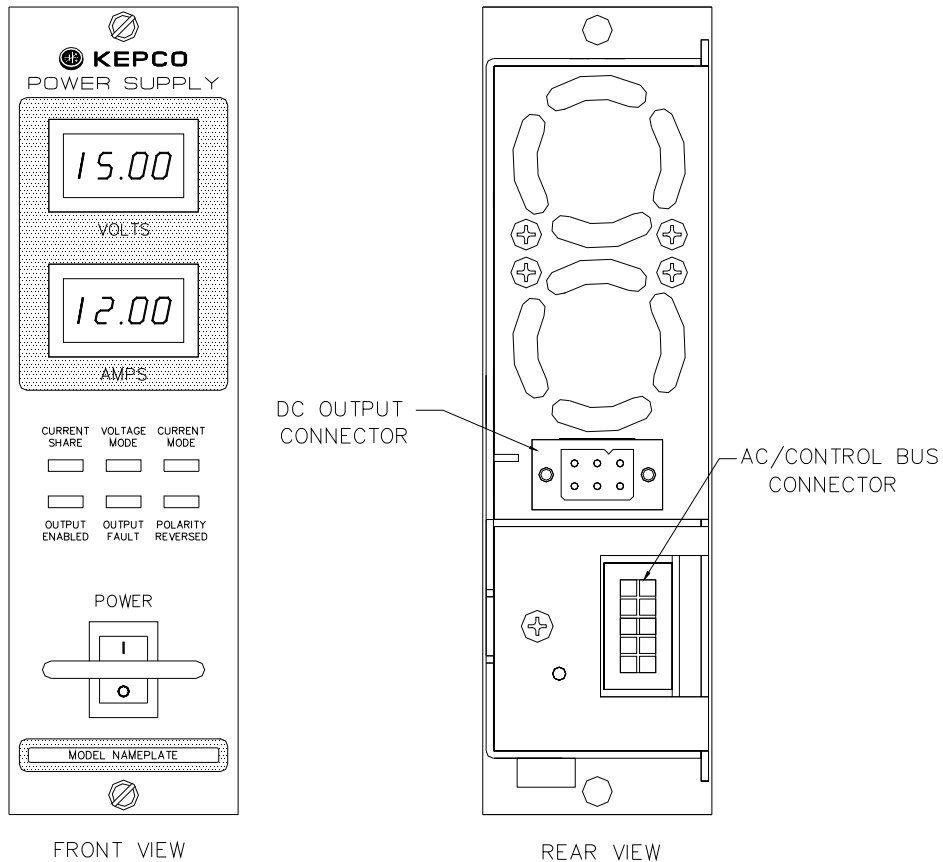

FIGURE 2-1. FRONT AND REAR VIEWS OF THE MST POWER MODULE

TABLE 2-3. REAR TERMINATIONS

REAR TERMINATION	FUNCTION
AC Input/Control Bus connector	Connects the MST Power Module to single-phase a-c power, safety ground, and two-wire IEEE 1118 bi-directional Control Bus.
DC output connector	Connects the MST Power Module output lines, sensing lines, frame ground lines and current share bus to the load.

2.5 PRELIMINARY CHECK-OUT

2.5.1 REQUIRED EQUIPMENT

- Host computer w/communication cable for selected controller
- Kepco Controller (See PAR. 1.4.1).
- RA 55 or CA 400 rack adapter; alternative is to use Input Power/Communication Cable (see Table 1-3)
- Load Interface Cable or mating load connector (see Table 1-3)
- Digital Voltmeter (DVM)
- Switch (SPST) rated 32V d-c, 1A

2.5.2 INITIAL SETUP

Initial set-up is as follows (See Figure 2-3):

1. Connect the Unit under test (UUT) to the computer/controller interface (refer to the appropriate Controller Instruction Manual and to the Rack Adapter (RA 55 or CA 400) Instruction Manual for source power connections). NOTE: An Alternative configuration using the Input Power Communication cable in place of the rack adapter may be used.
2. Install the MST Power Module into a vacant rack adapter slot (see PAR. 2.6.2).
3. Configure the Load Interface Cable as shown in Figure 2-2. If the Load Interface Cable is not available, wire load mating connector as shown in Figure 2-2.

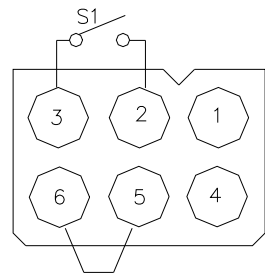

DC OUTPUT CONNECTOR
(REAR VIEW)

3041255

FIGURE 2-2. DC OUTPUT CONNECTOR CONFIGURATION FOR PRELIMINARY CHECKOUT

CAUTION: DO NOT repeatedly toggle the power ON/OFF switch as this may cause unit to fault.

4. Apply a-c power first to the MST power module(s) by setting Power ON/OFF switch on front panel to ON., then apply a-c power to the Controller.
5. Set switch S1 (Figure 2-3) to CLOSE SENSE position.

NOTE: If the sequence in step 4, above, is reversed (i.e., a-c power applied to the Controller first and MST power modules last), the operator must send an IEEE 488 Device Clear command via the Host Computer prior to issuing other commands.

For proper time delays between commands refer to PAR. 3.1.2. For details on the CIIL or SCPI commands, refer to the Instruction Manual for the applicable controller (see PAR. 1.4.1).

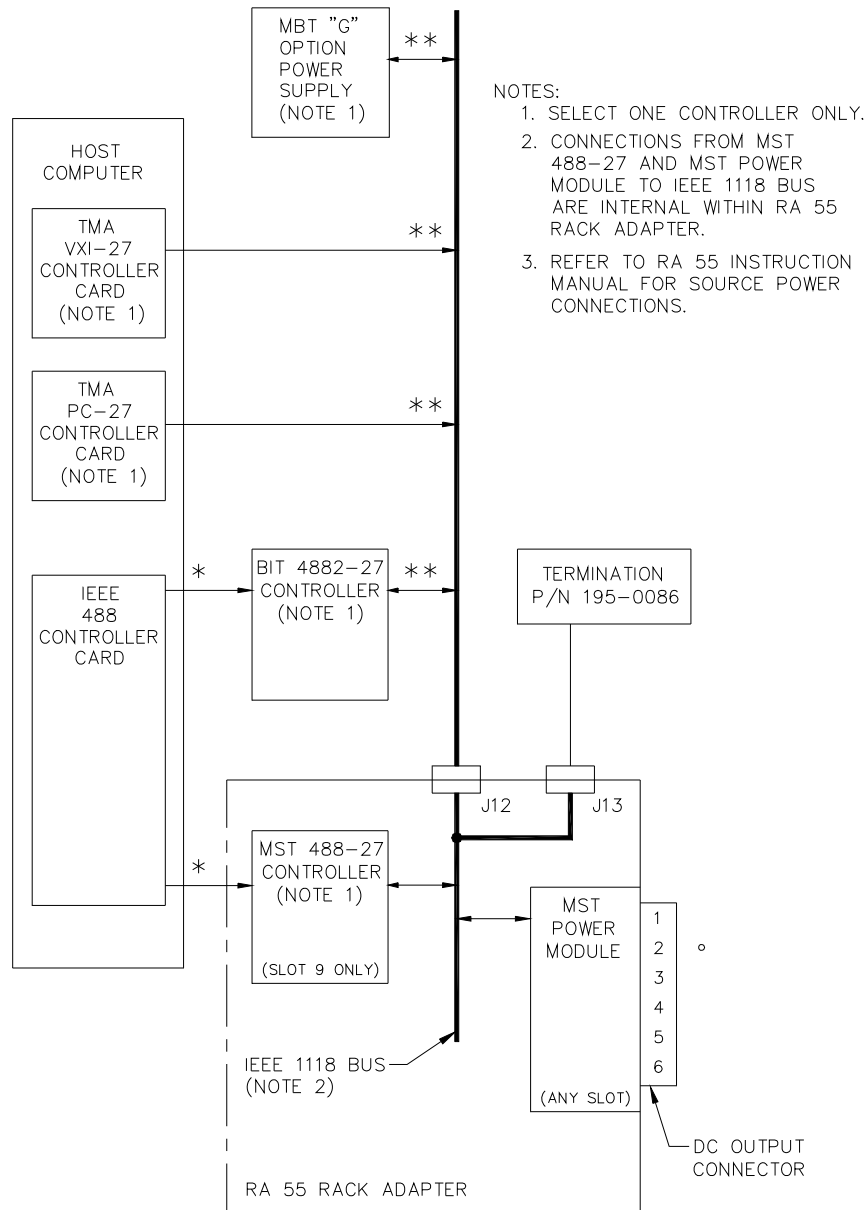

* IEEE 488 OR RS 232C CABLE CONNECTED TO CORRESPONDING PORT ON CONTROLLER.

** IEEE 1118 CABLE CONNECTED TO RA 55 J12 OR J13.

3041121

FIGURE 2-3. INITIAL CHECKOUT SETUP

2.5.3 CHECKOUT PROCEDURE

The following checkout procedure requires commands to be issued by the host computer in order to program the power module or read back information (voltage, current or status) from the power module; it does not include the IEEE 488 Bus Commands.

NOTE: The following procedure provides specific SCPI and CIIL commands where necessary to implement the applicable step. These commands are for a Model MST 36-5M Power Module set to Control Bus Address 1 (the factory default setting); for addresses other than 1, change commands accordingly (see applicable Controller Instruction Manual for details).

1. Issue commands from the host computer to initialize the Power Module.

SCPI COMMAND	CIIL COMMAND
*RST	DCL

NOTE: Both SCPI and CIIL commands must be issued in the proper syntax; incorrect syntax can result in the Power Module being “locked out” from accepting further commands. If this occurs, initialize the power module (see step 1 above). If the “locked out” condition persists, turn off MST power for approximately 10 seconds, then reapply power. (Refer to applicable Controller Instruction Manual for details regarding syntax.)

2. Issue commands from the host computer to set the MST Power Module to Voltage Mode, program output voltage to $+E_{MAX}$, current limit to I_{MAX} and enable the output.

SCPI COMMANDS	CIIL COMMANDS
FUNC1:MODE VOLT VOLT1 36; CURR1 5; OUTP ON	FNC DCS :CH1 SET VOLT 36 SET CURL 5 CLS :CH1

NOTE: E_{MAX} is the maximum output voltage of the unit listed in Table 1-1; I_{MAX} is the maximum output current of the unit as listed in Table 1-1 for 45° C.

3. Verify that VOLTAGE MODE and OUTPUT ENABLED indicators on front panel are on and VOLTS meter on front panel indicates E_{MAX} .
4. Connect DVM across pins 5 (+) and 2 (–) of the DC Output connector (Figure 2-3) and verify that DVM reads $+E_{MAX}$.
5. Issue commands from the host computer to read back voltage; verify that readback voltage is $+E_{MAX}$.

SCPI COMMANDS	CIIL COMMANDS
MEAS1:VOLT?	FNC DCS VOLT :CH1 INX VOLT FTH VOLT

6. Set switch S1 (Figure 2-3) to OPEN SENSE position. Verify that front panel OUTPUT ENABLED indicator is off, and VOLTS meter reads 0V.
7. Issue commands from the host computer to check Status and verify status reads DEV Load Path Fault (CIIL) or Relay Error (SCPI); refer to PAR. 3.1.1.

8. Verify that DVM connected across pins 5 and 2 of DC Output connector reads 0V.
9. Set switch S1 to CLOSE SENSE position and issue commands from the host computer to set the MST Power Module to Voltage Mode, program output voltage to $-E_{MAX}$, current limit to I_{MAX} and enable the output.

SCPI COMMANDS	CIIL COMMANDS
FUNC1:MODE VOLT VOLT1 -36; CURR1 5; OUTP ON	FNC DCS :CH1 SET VOLT -36 SET CURL 5 CLS :CH1

10. Verify that VOLTAGE MODE, POLARITY REVERSED and OUTPUT ENABLED indicators on front panel are on and VOLTS meter on front panel indicates E_{MAX} .
11. Connect DVM across pins 5 (+) and 2 (-) of the DC Output connector (Figure 2-3) and verify that DVM reads $-E_{MAX}$.
12. Issue commands from the host computer to read back voltage; verify that readback voltage is $-E_{MAX}$.

SCPI COMMANDS	CIIL COMMANDS
MEAS1:VOLT?	FNC DCS VOLT :CH1 INX VOLT FTH VOLT

13. Set switch S1 (Figure 2-3) to OPEN SENSE position. Verify that front panel OUTPUT ENABLED indicator is off, and VOLTS meter reads 0V.
14. Verify that DVM connected across pins 5 and 2 of DC Output connector reads 0V.
15. Set switch S1 to CLOSE SENSE position and issue commands from the host computer to set the MST Power Module to Current Mode, program output current to I_{MAX} and voltage limit to $+E_{MAX}$.

SCPI COMMANDS	CIIL COMMANDS
FUNC1:MODE CURR CURR1 5; VOLT1 36	FNC DCS :CH1 SET CURR 5 SET VLTL 36

16. Verify that CURRENT MODE indicator on front panel is on and AMPS meter on front panel indicates I_{MAX} .
17. Issue commands from the host computer to read back current; verify that read back current is I_{MAX} .

SCPI COMMANDS	CIIL COMMANDS
MEAS1:CURR?	FNC DCS CURR :CH1 INX CURR FTH CURR

2.6 INSTALLATION/REMOVAL

The MST Power Module is designed to be rack-mounted in an RA 55 Rack Adapter. Refer to Figure 1-2 for outline dimensions. For installation in confined spaces, care must be taken that the surrounding environment does not exceed the maximum specified ambient temperature (45° C); see PAR. 2.4. The MST Power Module may be shipped either individually, or already installed in an RA 55 Rack Adapter. Follow power module installation procedures in RA 55 Instruction Manual.

2.6.1 CHANGING CONTROL BUS ADDRESS (NODE OR CHANNEL NUMBER)

Each MST Power Module connected to the IEEE 1118 bus must have a unique address (also referred to as node or channel number). The address from 1 to 31 is selected by DIP selector switch S1 accessed through the top of the unit (see Figure 2-4) and can be changed in accordance with Table 2-4. This address is set at Kepco to 1.

NOTE: Although 31 unique addresses are provided, the maximum number of instruments which can be managed by the Kepco Controller is 27.

TABLE 2-4. NODE ADDRESS SELECTION

DECIMAL ADDRESS	SELECTOR SWITCH SECTION (SIGNAL LINE)				
	A3S1-4 (A4)	A3S1-3 (A3)	A3S1-2 (A2)	A3S1-1 (A1)	A3S1-0 (A0)
1	0	0	0	0	1
2	0	0	0	1	0
3	0	0	0	1	1
4	0	0	1	0	0
5	0	0	1	0	1
6	0	0	1	1	0
7	0	0	1	1	1
8	0	1	0	0	0
9	0	1	0	0	1
10	0	1	0	1	0
11	0	1	0	1	1
12	0	1	1	0	0
13	0	1	1	0	1
14	0	1	1	1	0
15	0	1	1	1	1
16	1	0	0	0	0
17	1	0	0	0	1
18	1	0	0	1	0
19	1	0	0	1	1
20	1	0	1	0	0
21	1	0	1	0	1
22	1	0	1	1	0
23	1	0	1	1	1
24	1	1	0	0	0
25	1	1	0	0	1
26	1	1	0	1	0
27	1	1	0	1	1
28	1	1	1	0	0
29	1	1	1	0	1
30	1	1	1	1	0
31	1	1	1	1	1

NOTE: If the Power Module is already installed in a Rack Adapter and it is necessary to change the control bus address, the Power Module must first be removed from the Rack Adapter as described in PAR. 2.6.3 below.

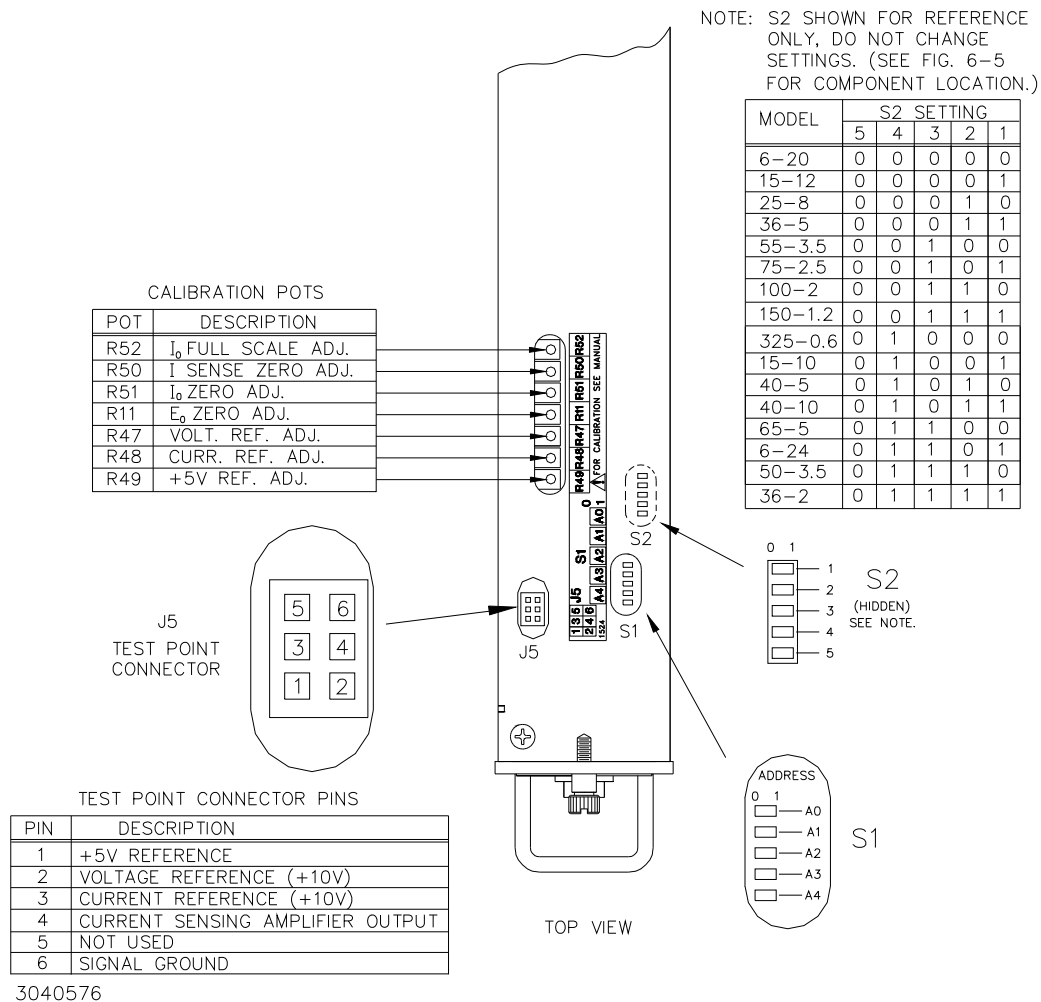

FIGURE 2-4. CONFIGURATION AND CALIBRATION CONTROLS AND TESTPOINTS

2.6.2 INSTALLATION

To install the MST Power Module in the RA 55 Rack Adapter or CA 400 case, proceed as follows:

1. The factory setting for the control bus address is 1; if address 1 is already in use, refer to PAR. 2.6.1 to change the address setting.

NOTE: If the Power Module is already installed in a Rack Adapter and it is necessary to change the control bus address, the Power Module must first be removed from the Rack Adapter as described in PAR. 2.6.3 below.

2. To ensure full engagement of the module interconnect to the RA 55 Rack Adapter or CA 400 case, pull out the two slotted captive thumb screws (at the front of the Module) and turn counterclockwise until the threads engage.

CAUTION

When inserting a Module into a Rack Adapter under power, the Module POWER switch must be placed in the OFF position prior to insertion.

3. Align slots of the Module with the guides of the Rack Adapter and insert Module into Rack Adapter slot. Secure with the two thumb screws (maximum torque applied to thumb screws is 10 foot-lbs).

2.6.3 REMOVAL

To remove the Power Module from the RA 55 Rack Adapter or CA 400 case, proceed as follows:

CAUTION

When removing a Module from a Rack Adapter under power, the Module POWER switch must be placed in the OFF position prior to extraction.

1. Loosen the two slotted captive thumb screws that hold the Module in place in the Rack Adapter until they disengage from the Rack Adapter.
2. Extract the module from the Rack Adapter using the front panel handle.

2.7 GROUNDING

Interconnections linking a stabilized Power Module to an a-c power source and a load are critical for both performance considerations and safety requirements. For optimum performance certain rules must be observed. These rules are described in detail in the following paragraphs.

2.7.1 SAFETY GROUNDING

National and international safety standards set procedures for the grounding of a metal cover and chassis of an instrument connected to an a-c power source.

When properly installed in the RA 55 Rack Adapter, the Power Module chassis is connected to the RA 55 safety ground terminal via the GROUND pins of the AC/Control Bus connector (Figure 2-6). For operation of the MST Power Module outside the RA 55 Rack Adapter, consult Kepco Applications Engineering for assistance.



RA 55 RACK ADAPTER MUST ALWAYS BE GROUNDED WHEN CONNECTED TO AN A-C POWER SOURCE.

2.7.2 D-C (OUTPUT) GROUNDING

D-C output connections are those between the Power Module and the load, including remote sensing connections. Despite precautions to eliminate noise such as shielding and twisted wire-pairs, output connections may pick up radiated noise of a wide frequency. To minimize such undesired effects, one side of the Power Module output/load may be grounded. Pin 4 of the DC

Output connector is connected to chassis (frame) ground. Although the d-c output is isolated from chassis or ground up to ± 500 V d-c, in certain applications the user may elect to terminate either the positive or negative terminals to chassis ground in order to optimize system performance.

Successful d-c grounding depends on careful analysis of the system operation; only general guide lines are provided here. One of the major points, however, is to avoid ground loops. Ground loops are created when two or more points of different ground potentials in the output circuit are grounded. An undesired signal (noise) is developed that is superimposed on the load (output potential). A way to avoid ground loops is to check for points of resistance to ground. Differences in ground potential can be avoided if the output circuit is completely isolated. A single point can then be selected along the Power Module output circuit and returned to ground with a single wire. This method is dependent on the specific application.

2.8 POWER MODULE TO LOAD INTERFACE

The general function of a voltage or current stabilized Power Module is to deliver rated output to the load. The load may be fixed or variable; resistive, capacitive, or inductive; and may be located close to or far away from the Power Module. The Power Module is designed for varied applications. The aim of the following paragraphs is to instruct the user in the interface of the Power Module to the load.

The perfect interface between a Power Module and load insures optimum performance. To approach this state of operation, one must be familiar with certain requirements, such as inter-connection guidelines, Ohm's Law and a-c theory.

Load Wire Selection - A stabilized d-c Power Module is not an ideal voltage or current source with zero output impedance (voltage mode) or infinite output impedance (current mode): All voltage sources have some amount of impedance which increases with frequency and all current sources have impedance which decreases with frequency (see Figure 2-5).

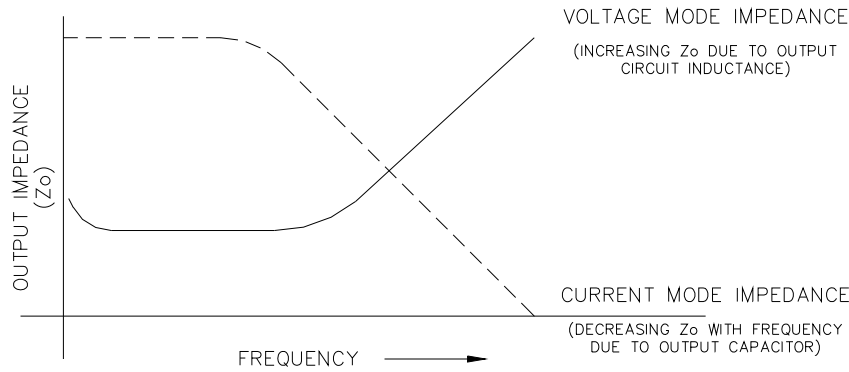

FIGURE 2-5. OUTPUT IMPEDANCE VS. FREQUENCY

A practical model for a voltage-stabilized Power Module includes a series inductance representing d-c and low frequency source impedance. Load leads should have minimum voltage drops (error sensing discussed in PAR. 2.10 below) and minimum inductance (error sensing does not compensate for this). Similarly a model for a current stabilized Power Module includes a parallel capacitor representing the d-c and low frequency source impedance. These considerations are important if:

- The load is constantly changing value.
- The load is switched “on” and “off.”
- The output of the Power Module is step programmed.
- The load is reactive.
- Dynamic output response of the Power Module is of concern.

2.9 CONNECTION, GENERAL

All input and output connections between the Power Module and RA 55 Rack Adapter are made automatically when the Power Module is fully seated in a Rack Adapter slot. Refer to the Rack Adapter Instruction Manual for instructions on connecting RA 55 output connectors to the load, a-c input power, and control signals.

The d-c output connector, labeled DC OUTPUT, is located on the back of chassis (Figure 2-6). For the DC Output Connector pin designations on MST units refer to Table 2-5.

TABLE 2-5. DC OUTPUT CONNECTOR PIN DESIGNATIONS

MST SIGNAL	CONNECTOR PIN
Output Terminal 1 (+)	6
Output Terminal 2 (-)	3
Sense Terminal 1 (+)	5
Sense Terminal 2 (-)	2
Current Share Bus	1
Module Chassis	4

TABLE 2-5. DC OUTPUT CONNECTOR PIN DESIGNATIONS

MST SIGNAL	CONNECTOR PIN
NOTE: The polarity for the terminals indicated above are for output enabled and polarity not reversed (normal).	

2.9.1 LOAD CONNECTION WITH LOCAL ERROR SENSING

The most basic power supply/load interface is a 2-wire connection between the power supply output terminals and the load. This connection method employs local error sensing which consists of connecting the error sense leads (pins 5 and 2) directly to the power supply output (pins 6 and 3). Its main virtue is simplicity: since voltage regulation is maintained at the power supply output, the regulation loop is essentially unaffected by the impedances presented by the load interconnection scheme. The main disadvantage is that it cannot compensate for losses introduced by the interconnection scheme and, therefore, regulation degrades directly as a function of distance and load current. The main applications for this method are for powering primarily resistive and relatively constant loads located close to the power supply, or for loads requiring stabilized current exclusively. The load leads should be tightly twisted to reduce pick-up.

2.9.2 LOAD CONNECTION WITH REMOTE ERROR SENSING

If the load is located at a distance from the power supply terminals, or if reactive and/or modulated loads are present, remote error sensing should be used to minimize their effect on the voltage stabilization. A twisted shielded pair of wires from the sensing terminals directly to the load will compensate for voltage drops in the load interconnection scheme (up to 0.5V maximum per wire); the termination point of the error sensing leads should be at or as close as practical to the load. For these conditions it is also recommended that some amount of local decoupling capacitance be placed at the error sense termination point to minimize the risk of unwanted pick-up affecting the remote error sense function. For very long power module/load interconnecting cables and/or reactive loads, it may be necessary to add decoupling capacitors between the power and sense terminals at the power module side of the cable to suppress oscillation due to cable inductance. A general recommendation is to install a network of one (1) 10 μ F, 6.3V capacitor paralleled by one (1) 0.1 μ F ceramic capacitor across each output sense pair (pins 6 to 5 and 3 to 2, respectively).

NOTE: As electrolytic capacitors are normally polarized make sure that the positive (+) terminal of each one are respectively connected to the +V (pin 6) and -S (pin 2) pins.

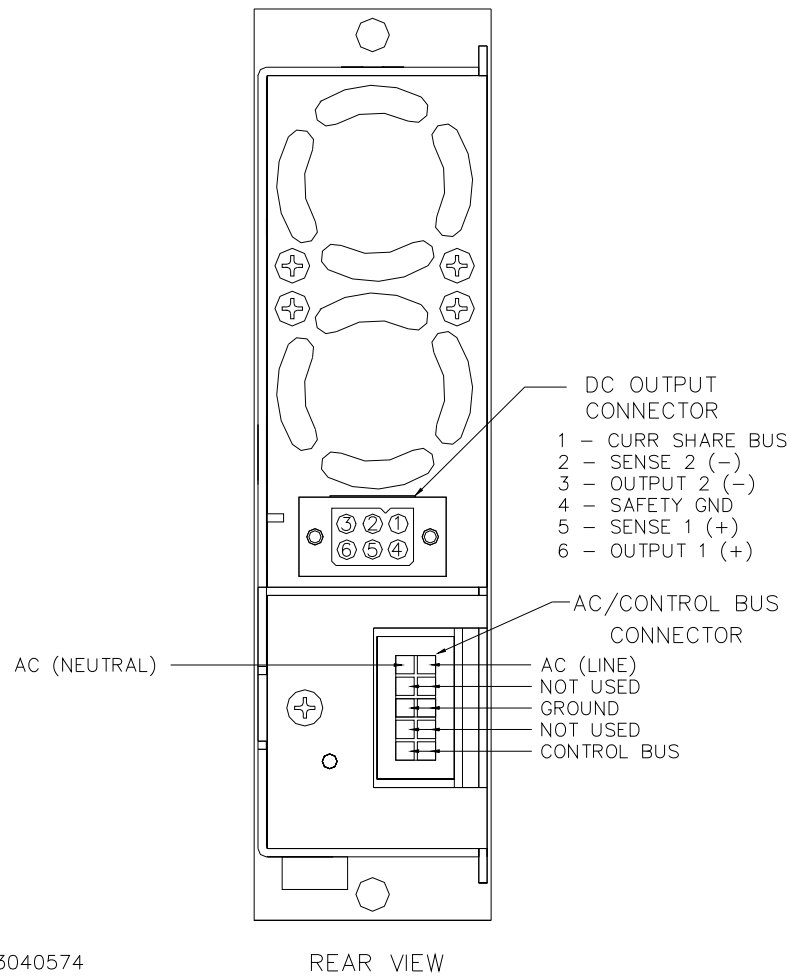

FIGURE 2-6. CONNECTOR LOCATIONS AND PIN ASSIGNMENTS

SECTION 3 - OPERATION

3.1 INTRODUCTION TO CONTROLLING THE MST POWER MODULE OUTPUT

The MST family of Power Modules is designed for remote operation only. Operating the power supply requires a series of commands to be sent to the Power Module from a host computer, via a selected IEEE 1118 bus compatible Controller (see PAR. 1.4.1). The commands may either be pre-programmed or sent individually using a keyboard, depending upon the controller selected.

The MST Power Module responds to both SCPI (Standard Commands for Programmable Instruments) and CIIL (Control Interface Intermediate Language) commands. SCPI and CIIL provide a common language conforming to IEEE 488.2 for instruments. For an explanation of SCPI and CIIL commands and program syntax, refer to the applicable controller Instruction Manual.

3.1.1 STATUS FLAGS (ERROR MESSAGES)

The MST Power Module supplies information to the controller regarding its operating condition when queried via the STAT:QUES:COND? command in SCPI, or via the STA command in CIIL. A listing of the standard error messages for both SCPI and CIIL appear in the Instruction Manuals for the various Kepco Controllers (see PAR.1.4.1). Table 3-1 lists the “catastrophic” status messages of both SCPI and CIIL, along with the related MST Power Module condition.

TABLE 3-1. ERROR MESSAGES

CIIL ERROR MESSAGE	SCPI STATUS MESSAGE	POWER MODULE CONDITION
DEV Power Loss	POWER LOSS	OVERVOLTAGE / OVERCURRENT (See PAR. 3.7.2) SOURCE POWER LOSS (See PAR. 3.7.4)
DEV Crowbarred	None	Not Supported
DEV Over Temperature	OVERTEMPERATURE	OVERTEMPERATURE (See PAR. 3.7.3)
DEV Overload	OVERLOAD	OPERATION IN MODE OTHER THAN PROGRAMMED MODE (See PAR's. 3.2.1, 3.2.2)
DEV Voltage Comparison Error	VOLTAGE ERROR	OUTPUT NOT AT PROGRAMMED VALUE
DEV Current Comparison Error	CURRENT ERROR	OUTPUT NOT AT PROGRAMMED VALUE
DEV Relay Not Opened DEV Relay Not Closed DEV Polarity Error	RELAY ERROR	DEFECT IN ISOLATION OR POLARITY RELAY OPERATION
DEV Load Path Fault	RELAY ERROR	OPEN SENSE LEAD OR OPEN POWER LEAD CONDITION (See PAR. 3.7.5)

3.1.2 TIMING REQUIREMENTS FOR A VALID STATUS

After sending a command that might affect the output of the Power Modules or their relays, it is recommended that the Status command be sent. For detailed information on this command refer to the applicable controller Instruction Manual. For the Controller/MST system status command to be valid, the required time delay before sending the command is as follows:

- After an Open, Close (CIIL only), OUTP ON or OFF (SCPI only), Change of Polarity, or Change of Mode, wait approximately 300 milliseconds.

- After a Confidence Test command or an Internal Self Test, wait approximately 400 milliseconds.
- After a Reset command, wait approximately 300 milliseconds.

3.2 OPERATING MODES

MST power modules permit the user to select the operating mode as either Voltage Mode or Current Mode, depending upon the characteristics of the load being driven by the power module. The following paragraphs describe the characteristics and method of selecting the operating mode; note the following:

- only one operating mode may be selected at a time.
- operating mode selection affects only the operation of the fault detector and not the rectangular operating characteristic of the power module.
- the MODE indicators on the front panel indicate the real-time operating mode of the Power Module.

3.2.1 VOLTAGE MODE

In this mode, the Power Module is programmed to behave as a voltage source. The user programs an operating voltage XX with a current limit YY based on the required voltage stabilization point and the maximum anticipated load current. The Power Module is now programmed to provide a stabilized output voltage XX to a load impedance greater than or equal to XX/YY; the VOLTAGE MODE indicator LED is on for these load conditions.

Load impedances below XX/YY are considered to be overloads, and the Power Module will modulate the output voltage between zero and XX as necessary to maintain the load current at YY. Operation with load impedances below XX/YY will result in the CURRENT MODE indicator LED going on and the VOLTAGE MODE indicator going off; a status query at this point will indicate a device overload condition. Increasing the load impedance to a value greater than or equal to the critical value indicated above will result in automatic return to normal operation.

3.2.2 CURRENT MODE

In this mode, the Power Module is programmed to behave as a current source. The user programs an operating current YY with a voltage limit XX based on the required current stabilization point and the maximum anticipated load voltage. The Power Module is now programmed to provide a stabilized output current YY to a load impedance less than or equal to XX/YY; the CURRENT MODE indicator LED is on for these load conditions.

Load impedances greater than XX/YY are considered to be overloads, and the Power Module will modulate the output current between zero and YY as necessary to maintain the load voltage at XX. Operation with load impedances greater than XX/YY will result in the VOLTAGE MODE indicator LED going on and the CURRENT MODE indicator going off; a status query at this point will indicate a device overload condition. Decreasing the load impedance to a value less than or equal to the critical value indicated above will result in automatic return to normal operation.

3.3 OUTPUT POLARITY REVERSAL

MST Power Modules are designed to permit reversal of output terminal polarity via a remote command. Polarity reversal is achieved via relay switching of both power and signal lines, and can be employed in both Voltage and Current operating modes. Polarity reversal can be pro-

grammed in advance of output activation (Standby) or “on-the-fly” (Active) while the output is enabled; both methods employ a “dry-switching” scheme in order to extend relay life.

For programming polarity reversal in Standby mode, the user simply issues the polarity reversal command prior to enabling the output; the Power Module will then present reversed output polarity when enabled.

For polarity reversal while the output is enabled, the action is somewhat more complex although essentially transparent to the user. Upon receipt of a polarity reversal command, the Power Module control circuit stores the previous output settings (mode, voltage and current setpoints, etc.). The output of the Power Module is immediately programmed to zero volts and zero amps. A time-out delay of 2 seconds maximum is employed to allow for discharge of any load capacitance through the Power Module’s return supply; during this time-out interval, the power supply waits for the output to reach zero volts. When zero volts is established, or at the end of the 2 second time-out, the relays are switched. The output is then reprogrammed to the stored settings and operation continues. During this sequence, error message generation is inhibited. Restoration of the output to normal polarity follows a similar path.

NOTE: The “return supply” current incorporated into MST Power Modules is limited to a maximum value which may in some cases be inadequate to fully discharge all external load capacitance. To ensure dry relay switching for all output conditions, the user must ensure that the external load capacitance can be discharged completely within the 2 second time-out interval by the available current, or dry switching will not take place. The maximum external capacitance value that can be discharged within the 2 second time-out interval is calculated as follows (see Table 3-2):

$$C \leq \frac{I \times T}{\Delta V}$$

- where C = Maximum external capacitance allowed to maintain dry switching (Farads)
- I = Return supply current (Amps)
- V = Output voltage (Volts)
- T = Time (Sec) = 2 seconds

CAUTION: FAILURE TO OBSERVE THE “DRY SWITCHING” CRITERIA NOTED ABOVE WILL CAUSE DAMAGE TO THE RELAYS AND VOID THE KEPKO WARRANTY.

In order to allow for settling time, the user should wait approximately 300 milliseconds after completion of polarity reversal before sending a status query in order to avoid erroneous fault messages.

TABLE 3-2. MAXIMUM EXTERNAL CAPACITANCE VALUES TO ENSURE DRY SWITCHING

MODEL	RETURN SUPPLY CURRENT (MILLIAMPS)	MAXIMUM EXTERNAL CAPACITANCE * (µF)
MST 6-20M	400	125,000
MST 15-12M	400	50,000
MST 25-8M	250	20,000
MST 36-5	165	8,800
MST 55-3.5	110	4,000
* Values shown for worst case: T = 2 seconds and ΔV = maximum voltage.		

TABLE 3-2. MAXIMUM EXTERNAL CAPACITANCE VALUES TO ENSURE DRY SWITCHING

MODEL	RETURN SUPPLY CURRENT (MILLIAMPS)	MAXIMUM EXTERNAL CAPACITANCE * (μ F)
MST 75-2.5	60	1,600
MST 100-2	44	880
MST 150-1.2	30	400
* Values shown for worst case: T = 2 seconds and ΔV = maximum voltage.		

3.4 OUTPUT ENABLE AND DISABLE

Enabling or disabling the output of an MST Power Module differs, depending upon whether it is operating as a voltage source or current source. The difference is determined by the opposite impedance characteristics of an ideal voltage vs. ideal current source. This section defines the “disable” function in terms of ideal voltage or current source characteristics, and details the exact method by which MST Power Modules provides the disable function.

For both voltage and current sources the “disable” condition is always represented by a “no-load” (zero load power) impedance. Regardless of whether the MST is operating in voltage or current mode (see PAR. 3.2), the “disable” condition must ensure that the MST provides zero power to the load, while ensuring full compliance to the load when subsequently enabled. The correct implementation of the disable function, whether for voltage mode or current mode, is automatic.

The definition of an ideal voltage source is a source which will supply stable voltage (V_o) into any load impedance within the limits of its compliance current range ($R_L = V_o/I_{MAX}$). For an ideal voltage source a no-load condition is then defined as infinite impedance, since this is the only load condition at which the delivered power ($V_o \times I_o$) is zero. MST Power Modules provide this function by opening all power relays, thus providing an open circuit to the load from the stabilizer output. Enabling the voltage source is accomplished by closing the appropriate relay contacts, depending upon selected output polarity, thus connecting the stabilizer output to the load.

The definition of an ideal current source is a source which will supply stable current (I_o) into any load conductance within the limits of its compliance voltage range ($G_L = I_o/V_{MAX}$). For an ideal current source a no-load condition is then defined as infinite conductance (zero impedance) since this is the only load condition at which the delivered power is zero. MST Power Modules provide this function by closing all four power relays, thus placing a short circuit ($R_L=0$) at the output of the load stabilizer. While “disabled,” output current from the MST load regulator continues to circulate within the power module and through the shorted power relays. Enabling the current source is accomplished by opening the appropriate relays contacts, depending upon the selected output polarity, thus allowing the output current to flow through the load.

As with the output polarity reversal function described in PAR. 3.3, a “dry switching” scheme is employed during the disable and enable functions. For both voltage and current modes of operation, the CIIL command to enable the output at the load is Close (CLS), and to disable the output at the load is Open (OPN); the corresponding SCPI commands are OUTP ON and OUTP OFF, respectively.

3.5 PARALLEL OPERATION

MST Power Modules are specifically designed for operation in parallel, either for increased power or for fault redundancy. The output stabilizer incorporates an active load-sharing scheme to ensure equal distribution of load current among all paralleled modules, resulting in reduced operating stress and higher reliability. The load-share circuitry employed is a single-wire type with the positive error sense connection providing the signal return path.

To determine the number of Power Modules needed for a specific application, the user divides the total required load current (including any transient peaks) by the Power Module's rated current, rounding the result up to the next whole number if necessary. This method determines "N", the minimum number of power modules needed to support the load. For redundant applications this number is increased based on the desired redundancy factor (N+1, N+2, etc.). For non-redundant applications, the user can reduce overall power system operating stress by increasing the number of modules above N.

For parallel operation, all Power Modules should be same model. The module d-c outputs and error sense leads are wired in parallel to the load; the load share terminals from each DC Output connector are daisy-chained together. The user must ensure that the load and sense wiring minimizes loop inductance to prevent stray pickup from injecting noise into the load share signals. Twisted pairs (shielded, if necessary) should be used for both power and error sense leads when remote error sensing is used, with all error sensing lines terminated to the same physical location; if possible, the user should employ local error sensing.

Program each module for Voltage Mode operation at identical output voltage and current limit. The load sharing circuitry will automatically select the "load master" as the module with the highest "effective" voltage supplying power to the output bus; all other modules operate as slaves and are indicated as such by the CURRENT SHARE indicator LED on the front panel of the power module. Since MST Power Modules are enabled sequentially, the enabled modules will generate output voltage errors until the minimum number of modules (N) are turned on; the user should ignore these error flags until all modules are enabled (SCPI provides a method of masking these flags using software). The same is true if modules are disabled sequentially.

3.6 SERIES OPERATION

MST Power Modules are designed to allow series operation to achieve higher output voltage if desired. Series operation requires detailed investigation into all possible output conditions which may result from either normal or abnormal operation to ensure that the power supplies are not exposed to undue stress, especially voltage. This need is increased for MST Power Modules which, because of the sequential turn-on characteristic, may be exposed to greater risk during output enabling and disabling sequences. Users wishing to operate MST Power Modules in series are directed to contact Kepco Applications Engineering for specific guidance.

3.7 FAULT PROTECTION

In addition to providing protection against externally generated faults, MST Power Modules incorporate fault protection circuitry which protects the load in the event of an internal failure or malfunction which may result in loss of output control. The fault classifications are output overvoltage, output overcurrent, internal overtemperature, source power loss and open sense wire. A description of the fault detectors associated with these faults is provided in the following paragraphs.

The response of the Power Module to any of these faults (except for open sense/power lead) is a fault shutdown procedure consisting of the following:

- All output power and signal relays are immediately opened, isolating the Power Module from the load;
- Output voltage and current are programmed to zero;
- The dc-dc converter which powers the output stabilizer is latched off;
- A fault status flag is sent to the Controller indicating a catastrophic failure. Upon receiving a fault status flag, the Controller removes that Control Bus address from the look-up table, preventing further commands from being directed to the faulty power module.

If an open sense lead or open power lead condition is detected, the fault shutdown procedure is as follows:

- All output power and signal relays are immediately opened, isolating the Power Module from the load;
- Output voltage and current are programmed to zero;
- A fault message is sent to the controller (Load Path Fault in CIIL, Relay Error in SCPI).

3.7.1 FAULT RECOVERY

Recovery from a fault status flag condition (described above) requires that the user cycle source power off for a minimum of 5 seconds. After reapplication of source power, a device reset command (RST) must be sent to the module's Control Bus address to restore the address to the look-up table. This procedure eliminates any possibility of casual reapplication of a Power Module to the system load after symptoms of a catastrophic module failure have been detected.

3.7.2 TRACKING OVERVOLTAGE AND OVERCURRENT DETECTORS

The output stabilizer control circuitry of the MST Power Module includes separate overvoltage and overcurrent tracking amplifiers. These devices monitor the actual output voltage and current supplied by the Power Module and compare them to the programmed voltage and current values. In the event that either parameter exceeds the programmed limit by an amount equal to 10% of the Power Module's rated voltage or current, the circuit initiates a fault shutdown procedure including a Device Power Loss status flag. The tolerance of the fault thresholds are $\pm 3\%$.

3.7.3 OVERTEMPERATURE DETECTORS

Any one of a number of internal or external conditions (i.e., elevated ambient temperature, clogged vent holes, cooling fan failure, etc.) can cause elevation of internal heat sink temperatures to unsafe levels. If unattended, the resultant temperature rise of the power devices will lead to eventual destructive failure. MST Power Modules incorporate two internal thermostatic switches to detect unsafe internal operating temperatures. One is located on the heat sink related to the input preregulator and dc-dc converter, while the second monitors the heat sink related to the output stabilizer. If the temperature of either heat sink rises above a predetermined safe temperature, the related thermostat will change state, initiating a fault shutdown and generating a Device Overtemperature status flag. The thermostat will reset upon return of the heat sink to acceptable operating temperature, however the module recovery procedure (see PAR. 3.7.1) must still be performed.

3.7.4 A-C LOSS DETECTOR

Although MST Power Modules are designed to provide a minimum of 21.5 milliseconds of output hold-up time (one full cycle of 47Hz power), loss of source power for extended periods will eventually result in complete Power Module shutdown. Additionally, certain power loss intervals can create a condition where the internal bias supply for the digital control circuitry decays partially, but not enough to force a system interrupt and reset; when this occurs, it is possible that digital communication and processing can be corrupted without warning or notice. To prevent this, MST Power Modules incorporate a power loss detector which will initiate a fault shutdown with an accompanying Device Power Loss status flag if the internal bulk d-c storage capacitor voltage falls to a level where quality of the internal bias voltages is questionable.

3.7.5 OPEN SENSE/POWER WIRE PROTECTION

In the event that the error sense leads (+S, -S) become disconnected from the power leads, the output voltage will attempt to rise uncontrollably; the MST Power Module fault detection circuitry continuously monitors the error sensing leads to protect against this occurrence. If an open sense lead or power lead condition is detected, the fault detector immediately issues a string of commands which reset the output status to Voltage Mode, Output Disabled (all output relays open) and programs the output voltage and current limit to zero. At the same time, a fault message is sent to the controller (Load Path Fault in CIIL, Relay Error in SCPI). Once the open sense or power lead condition is corrected, the power module is ready to accept additional commands without any further recovery measures; manual reset is not required.

The open sense/power wire protection circuitry can also be triggered by a power lead voltage drop in excess of the 0.5V maximum specified headroom. If the error sense lead connections appear to be correct, the user should double-check the size of the power leads to verify adequate margin. Contact Kepco Applications Engineering for assistance if necessary.

3.8 CALIBRATION

Calibration of the MST Power Module is recommended for any of the following conditions.

- The unit has been moved.
- Operating environment (temperature, humidity, etc.,) has been altered.
- Periodic maintenance determined by user.
- Inaccurate measurements are suspected.

Perform the procedures outlined below in sequence (see Figure 2-4 for the location of calibration controls). Calibration adjustments are recommended only when the test point value exceeds the indicated tolerance on the measured value. Note that the measured value tolerance is generally an order of magnitude looser than the adjustment tolerance. This avoids unnecessary recalibration, while providing a precision adjustment if calibration is required.

NOTE: E_{MAX} is the maximum output voltage of the unit listed in Table 1-1; I_{MAX} is the maximum output current of the unit as listed in Table 1-1 for 45° C.

3.8.1 EQUIPMENT REQUIRED

Calibration of MST Series Power Modules requires the following equipment:

- Host computer
- RA 55 or CA 400 Rack Adapter, or Input Power/Communication Cable (see Table 1-3)
- Controller Module (Kepco MST 488-27 or TMA Series)
- Digital Voltmeter (DVM): 6½ digit display, 10 μ V resolution
- Precision Current Shunt: $R_{SHUNT} < 0.02 (E_{MAX} / I_{MAX})\Omega$

where: E_{MAX} = rated Power Module output voltage (e.g., 36V for MST 36-5)

I_{MAX} = rated Power Module output current (e.g., 5A for MST 36-5)

NOTE: To avoid errors due to temperature drift of the shunt, a power rating of greater than 10 times actual dissipation is recommended. The above calculation results in a maximum shunt power dissipation of less than 4W, a 100W shunt is adequate for all models)

- Miscellaneous programming interface cables, load cables, etc.

Install the MST Series power module under test (UUT) in the calibration test set-up shown in Figure 3-1

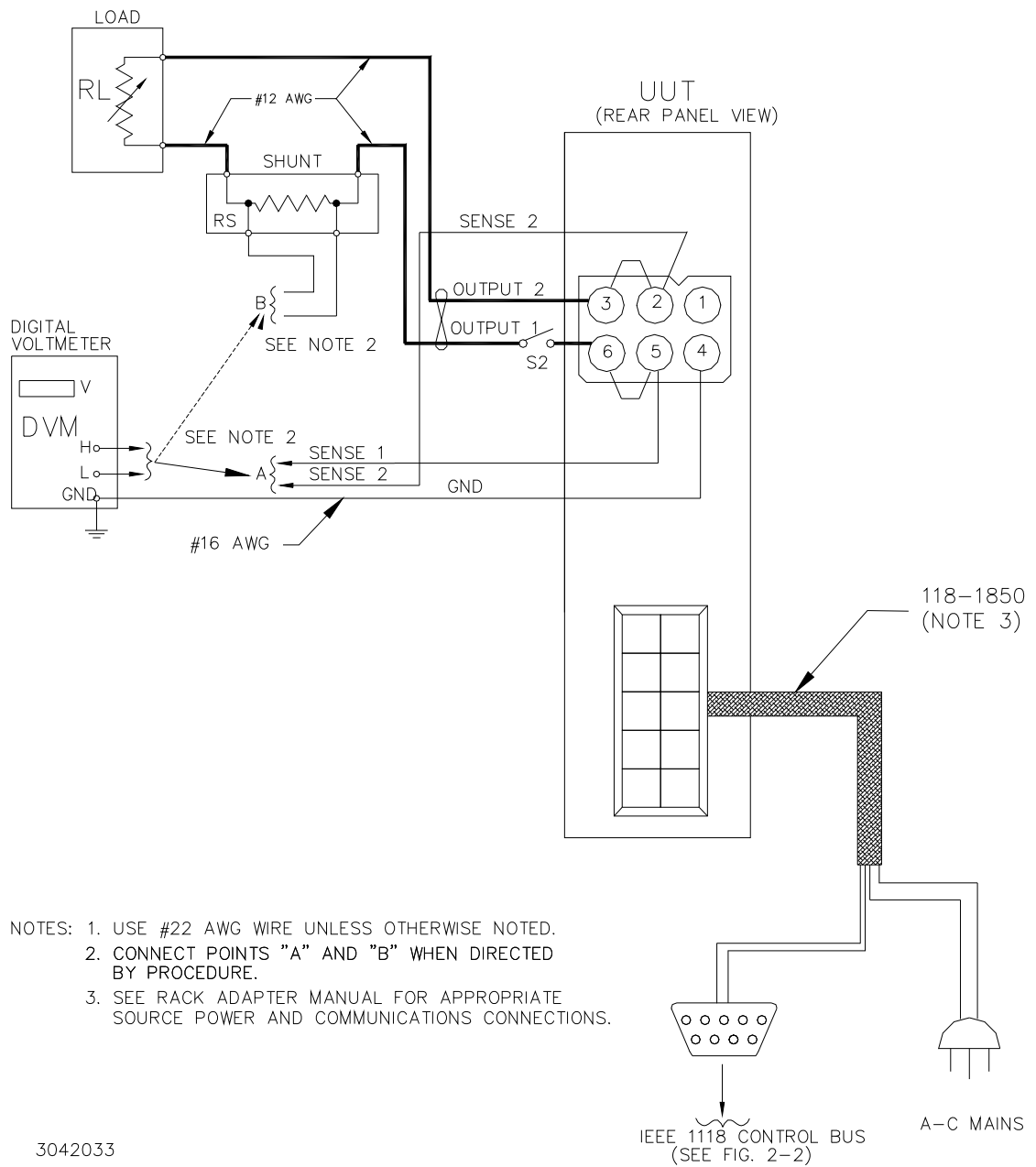

FIGURE 3-1. CALIBRATION TEST SET-UP

3.8.2 +5 VOLTS REFERENCE ADJUST (R49)

This procedure establishes the +5V reference voltage used by the analog circuits.

1. Disconnect the load and turn on the UUT. Proceed to step 3 if VOLTAGE MODE indicator is on.

2. If the CURRENT MODE indicator is on, issue a command from the host computer to set the UUT to Voltage mode. Verify that VOLTAGE MODE indicator is on.
3. Issue a command from the host computer to reset the UUT. This causes the UUT to be programmed to zero volts.
4. Connect the voltmeter to test connector J5, pins 1 (REF) and 6 (GND) (see Figure 2-4) and verify meter reads between $5.00000V \pm 500\mu V$ volts. If meter reading is outside these limits, adjust potentiometer R49 for reading of $+5.00000V \pm 50\mu V$.

3.8.3 OUTPUT VOLTAGE (E_O) ZERO ADJUST (R11)

This procedure adjusts the offset of the voltage comparison amplifier to be zero for a programmed output voltage of zero.

1. Configure DC OUTPUT connector as shown in Figure 2-3 and close S1.
2. With the load disconnected, issue a command from the host computer to enable the output (output relays closed). Verify OUTPUT ENABLED and VOLTAGE MODE indicators are on.
3. Connect DVM to DC output connector (see Figure 2-3) pin 5, Sense 1 (+) and pin 2, Sense 2 (-) and verify that output is $0V \pm 500\mu V$.
4. If the measured output is outside these limits adjust potentiometer R11 for reading of $0.00000V \pm 50\mu V$.

3.8.4 CURRENT SENSE ZERO ADJUST (R50)

This procedure adjusts the current sensing amplifier to zero with no current flowing through the current sensing resistor.

1. Issue command from the host computer to reset the UUT.
2. Verify VOLTAGE MODE indicator is on.
3. Connect voltmeter to test connector J5, pins 4 (CSNS - Current Sense) and 6 (GND) and verify meter reads $0.00000V \pm 500\mu V$. If meter reading is outside these limits, adjust potentiometer R50 for $0.00000V \pm 50\mu V$.

3.8.5 OUTPUT CURRENT I_O ZERO ADJUST (R51)

This procedure adjusts the offset of the current comparison amplifier to be zero for a programmed output current of zero.

1. Issue commands from the host computer to set the UUT to Current Mode, program output current to 0.0A, voltage limit to E_{MAX} and disable the output.
2. Verify CURRENT MODE indicator is on and OUTPUT ENABLED indicator is off.
3. Connect voltmeter to test connector J5, pins 4 (CSNS - Current Sense) and 6 (GND) and verify voltmeter reads $0.0000V \pm 500\mu V$. If voltmeter reading is outside these limits, adjust potentiometer R51 for $0.0000V \pm 100\mu V$.

3.8.6 VOLTAGE REFERENCE ADJUST (R47)

This procedure adjusts the internal full scale reference voltage to produce the full scale output voltage E_{MAX} when the full scale voltage is programmed.

1. Issue commands from the host computer to set the UUT to Voltage Mode, program current limit to I_{MAX} , output voltage to E_{MAX} and enable the output.
2. Verify VOLTAGE MODE and OUTPUT ENABLED indicators are on.
3. Connect the voltmeter to DC output connector (see Figure 2-3) pin 5, Sense 1 (+) and pin 2, Sense 2 (–) and verify measured value is within ± 1 LSB (1/4096) of E_{MAX} . If measured value exceeds the acceptable range, adjust potentiometer R47 to E_{MAX} , within the R47 adjustment tolerance of ± 0.5 LSB (1/8192) of E_{MAX} .

3.8.7 CURRENT REFERENCE ADJUST (R48)

This procedure establishes the maximum value of the internal current reference voltage so that the readback current matches the programmed current.

1. Turn off UUT and connect precision shunt across DC Output connector pin 6, Output 1 (+), and pin 3, Output 2 (–).
2. Turn on UUT.
3. Issue commands from the host computer to set the UUT to Current Mode, program output current (I_O) to $0.99 \times I_{MAX}$, voltage limit to E_{MAX} and enable the output.
4. Verify that CURRENT MODE and OUTPUT ENABLED indicators are on.
5. Issue commands from the host computer to read back current.
6. Verify that the read back value (step 5) is within ± 1 LSB (4096) of the programmed value (step 3). If readback value exceeds acceptable range, adjust R48 for readback value within ± 0.5 LSB (1/8192) of the programmed value.

3.8.8 CURRENT (I_O) FULL SCALE ADJUST (R52)

This procedure adjusts the gain of the current sensing amplifier so that the actual full scale output current matches the programmed output current.

1. Issue commands from the host computer to set the UUT to Current Mode, program output current (I_O) to $0.99 \times I_{MAX}$, voltage limit to E_{MAX} and disable the output. The unit must be operating for a minimum of 20 minutes in Current Mode with output disabled to avoid drift due to temperature fluctuations.
2. Enable the output and verify that CURRENT MODE and OUTPUT ENABLED indicators are on.
3. Record the output current as measured across the external shunt.

4. Issue commands from host computer to read back current.
5. Compare the read back current (step 4) to the measured current (step 3). Verify that measured current is equal to readback current within the acceptable range of ± 1 LSB (1/4096) of I_{MAX} . If the acceptable range is exceeded, adjust R52 until measured current is within ± 0.5 LSB (1/8192) of read back current, repeating steps 1 through 5 as necessary.