

INSTRUCTION MANUAL

MSK 40-2.5M POWER SUPPLY

LINEAR COMPACT BENCHTOP TEST EQUIPMENT

KEPCO INC.
An ISO 9001 Company.



IMPORTANT NOTES:

- 1) This manual is valid for the following Model and associated serial numbers:

MODEL	SERIAL NO.	REV. NO.
-------	------------	----------
- 2) A Change Page may be included at the end of the manual. All applicable changes and revision number changes are documented with reference to the equipment serial numbers. Before using this Instruction Manual, check your equipment serial number to identify your model. If in doubt, contact your nearest Kepco Representative, or the Kepco Documentation Office in New York, (718) 461-7000, requesting the correct revision for your particular model and serial number.
- 3) The contents of this manual are protected by copyright. Reproduction of any part can be made only with the specific written permission of Kepco, Inc.

Data subject to change without notice.

©2017, KEPCO, INC.
P/N 243-0835-R11



KEPCO, INC. • 131-38 SANFORD AVENUE • FLUSHING, NY. 11355 U.S.A. • TEL (718) 461-7000 • FAX (718) 767-1102
email: hq@kepcopower.com • World Wide Web: <http://www.kepcopower.com>



CE MARK ADDENDUM

This Kepco unit is a general purpose power supply, intended to be used as a component within an automated test equipment systems or as an apparatus used in electronic research laboratories.

The manufacture of the Kepco model is based upon IEC 478 document 1-4 and 50 years of experience using the best practice in the design and manufacture of commercial and industrial power supplies.

On May 3, 1989, the Council of European Communities issued a Council Directive regarding the Electromagnetic Compatibility (EMC) for virtually all electrical equipment entering the 15-member European Union (EU). Additional amendments were also issued by the Council on April 28, 1992 and July 22, 1993.

This document is known as EMC Directive 89/336/EEC. The regulation under this EMC Directive becomes mandatory for all electrical equipment coming to market within the EU as of January 1, 1996.

The EMC Directive requires that electrical or electronic products generate no harmful emissions and to be immune to electrical disturbances. This EMC directive, via the published harmonized standards for specific apparatus or the published generic standards for a specific class of products, defines the mandatory permissible electromagnetic disturbance levels that the equipment is liable to cause and its degree of immunity to such signal.

Presently, there are no published harmonized standards approved or in effect regarding EMC requirements for electrical equipment for Measurement, Control and Laboratory Use. This product falls within the Laboratory Use category.

Under the EMC generic standards in effect, the EMC compliance for some products is deferred to engineering judgement regarding the need for full, partial or no testing for compliance.

This power supply is a Direct Current (DC) power supply using linear design technology and there are no high frequency switching circuits within the power supply that may generate or emit any electromagnetic disturbances.

There are no electromagnetic disturbances, conducted (in the frequency range of 150KHz to 30MHz) or radiated (in the frequency range of 30 MHz to 1GHz), produced by this power supply that may degrade the performance of other devices, apparatus or systems whose performance may be degraded by electromagnetic disturbances produced by electrical or electronic apparatus.

Therefore, in compliance to EMC Directive, Kepco finds that this product meets the EMC Directive for compatibility without the need to perform conducted or radiated emission testing.

The generic EMC immunity standard EN 50082-1 applies to products intended for use in the residential, commercial or light-industry environment, for which no dedicated product or product-family immunity standard exists. The Kepco power supply is an apparatus that falls in the category of products covered by this standard. It is a rack mountable power supply intended to be installed within RF shielded and grounded electronic system cabinet or enclosure and it is intended to be used in electronic and test laboratories.

For proper operation of this model in the above environment, the system integrator may be required to provide the proper protection against electromagnetic disturbances. This can be achieved through the proper use of RFI filter and/or surge protectors for the "entry" cables and RF gaskets and covers for the shielded apertures in the environment in which this power supply is installed.

This Kepco power supply is designed to meet the following EMC immunity standards:

Enclosure port (radiated):

- Immunity to Electrostatic Discharge (ESD)
 - Test standard: EN 61000-4-2
 - Test specification: 4KV Direct contact; 8KV Air discharge
 - Performance criteria: B
- Immunity to Radio-Frequency Electromagnetic Field
 - Test standard: EN 61000-4-3
 - Test specification: Amplitude modulated:
 - 80MHz - 1GHz @ 10Vrms/m (unmodulated)
 - 80% (AM @ 1KHz)Pulse modulated:
 - 900 ± 5MHz @ 10Vrms/m (unmodulated)
 - 50% Duty cycle; 200Hz Repetition frequency.
 - Performance criteria: A
 - Notes: Unit should be used within an RF shielded and grounded enclosure or cabinet.
- Immunity to Power-Frequency Magnetic Field
 - Test standard: EN 61000-4-8
 - Test specification: 50Hz @ 30A(rms)/m
 - Performance criteria: A

AC input, DC output and Earth ports (conducted)

- Immunity to Radio-Frequency
 - Test standard: EN 61000-4-6
 - Test specification: Common mode; 150KHz - 80MHz; 10Vrms(unmodulated)
 - Performance criteria: B
- Immunity to Electrical Surges
 - Test standard: EN 61000-4-5
 - Test specification: 1.2/50 (8/20) microseconds; Tr/Th
 - 4KV - common and differential mode (AC input port only)
 - 0.5KV - common and differential mode (DC output port only)
 - Performance criteria: B
 - Notes: System integrator may be required to add surge protectors at the power supply input and/or output terminals to meet the above electrical surge specification.

TABLE OF CONTENTS

PARAGRAPH		PAGE
SECTION I—INTRODUCTION		
1-1	Introduction	1-1
1-3	Specifications.....	1-1
1-4	General Specifications.....	1-1
SECTION II—INSTALLING AND USING THE MSK		
2-1	Unpacking and Installing	2-1
2-5	The Preview Feature	2-1
2-10	Crowbar Protection.....	2-2
2-11	Error Sensing	2-2
2-13	Connecting Loads	2-2
2-16	Local/Remote Programming.....	2-4
SECTION III—THEORY OF OPERATION		
3-1	General	3-1
3-3	Physical Layout	3-1
3-4	Power Circuits	3-1
3-8	Reference Voltage.....	3-1
3-11	Voltage Control	3-3/3-4
3-12	Current Control	3-3/3-4
3-13	Mode Control and Preview	3-3/3-4
3-15	Pass Elements.....	3-3/3-4
3-16	Overvoltage Protection.....	3-3/3-4
SECTION IV—MAINTENANCE, TESTING AND TROUBLESHOOTING		
4-1	General	4-1
4-3	Measuring Characteristics	4-1
4-5	Load Effect.....	4-1
4-6	Source Effect.....	4-1
4-7	Temperature Effect	4-1
4-8	Ripple and Noise	4-1
4-10	Test Setup for Measuring Characteristics and Troubleshooting.....	4-1
4-14	Measuring Load Effect	4-2
4-16	Measuring Ripple and Noise.....	4-2
4-19	Troubleshooting	4-2
4-22	Resistor R9 Alignment.....	4-3/4-4
SECTION V—PARTS LIST AND DIAGRAMS		
5-1	General	5-1/5-2
5-3	Ordering Information.....	5-1/5-2

LIST OF ILLUSTRATIONS

FIGURE		PAGE
1-1	Controls and Indicators.....	2-1
2-1	Voltage and Current Crossover	2-1
2-2	Correct and Incorrect Method of Connecting Loads.....	2-2
2-3	Outline Drawing.....	2-3/2-4
3-1	Simplified Schematic, Voltage and Current Control	3-2
4-1	Test Setup for Measuring Load Effect.....	4-2
5-1	Component Location (A2), Main Chassis Assembly with Front Panel (A4) and Heat Sink Assembly (A3)	5-17/5-18
5-2	Component Location, Control Assembly (A1).....	5-19/5-20
5-3	Main Schematic Diagram	5-21/5-22

SECTION I—INTRODUCTION

1-1 INTRODUCTION: The Kepco MSK Series is comprised of five models of compact linear benchtop power supplies designed for maintenance shop or laboratory testing of microprocessor and logic circuitry. Each model provides 100 Watts of stabilized voltage or current over a choice of five voltage or current output ranges. Regulation is provided by a high gain linear series pass circuit with forced air heat sink cooling. A "preview" feature allows output to the load to be turned off while values for the current or voltage mode are selected using a precision control and digital LCD numeric displays of current and voltage. Units feature good stability with low noise and accurate resettability. Units operate from either 115V or 230V ac input by changing a switch setting at the rear.

1-2 Models in this Kepco Series are as follows:

Model	D-C Output Range		Power
	Volts	Amps	Watts
MSK 10-10M	0- 10	0-10	0-100
MSK 20-5M	0- 20	0-5	0-100
MSK 40-2.5M	0- 40	0-2.5	0-100
MSK 60-2M	0- 60	0-2	0-120
MSK 125-1M	0-125	0-1.0	0-125

1-3 SPECIFICATIONS: Stability specifications of the MSK Series are as follows (percentages are referenced to maximum rated voltage or current):

	Voltage Mode	Current Mode
Source effect:	0.01%	0.01%
0 Load to ~ Max. Rated Load	0.01%	0.05%
Drift, 8 hrs:	0.01%	0.02%
Temperature: Per °C	0.01%	0.02%
Ripple and noise: rms,	0.5mV	0.02%
p-p,	3.0mV	0.1%

1-4 GENERAL SPECIFICATIONS: Table 1-1 contains general specifications that apply to all models of the MSK Series.

SPECIFICATION	RATING/DESCRIPTION	CONDITION
INPUT		
Voltage	105-125, 210-250V a-c	User selectable (rear switch)
Current	2.8A ms max.	Maximum load, 115V a-c
Frequency	47-63 Hz	
OUTPUT		
d-c output	Transistor	Series pass
Type of stabilizer	Automatic crossover	Voltage/current
Voltage adjustment range	0 to 100% of rating	0 to +45 °C
Current adjustment range	0 to 100% of rating	0 to +45 °C
Error sense	0.5V per load wire	Voltage allowance ⁽¹⁾
Voltage recovery	50µsec typ, 100µsec max	Step load change between 10% and 100% I _o max
Isolation voltage	500V d-c or peak	Output to ground
Leakage current	< 100 microamperes	rms at 115V a-c
Output to ground	< 50 microamperes	p-p at 115V a-c
OVP	Crowbar SCR	Transient 5 milliseconds or more
CONTROL		
Voltage/Current	10-turn precision rheostat	
MECHANICAL		
Input connections	IEC detachable line cord	
Output connections	Front panel binding posts	Output, sense & ground ⁽²⁾
Meters	Two 3½" LCD digital displays	Accuracy ½ least significant bit
Cooling	1800 rpm low noise blower	
Dimensions ⁽³⁾ (H x W x D)	5½ x 8½ x 13½ 146.6 x 206.6 x 334	Inches mm
Finish: Kepco STD BF00010-85	Light gray color	Front panel, 2 tone
Weight (packed for shipment)	19 Lb (8.6 Kg)	MSK 10-10M, 20-5M, 40-2.5M
	22 Lb. (10 Kg)	MSK 125-1M

⁽¹⁾ An additional volt is provided in the output beyond the rating for this purpose.

⁽²⁾ Ground terminal permits grounding of either plus or minus output terminal.

⁽³⁾ Including feet.

TABLE 1-1 GENERAL SPECIFICATIONS

Green LED indicates that the unit is in the voltage mode. The regulated voltage will be indicated on the voltage digital display.

Amber LED indicates that the unit is in the current mode as determined by the crossover point set by the voltage and current controls.

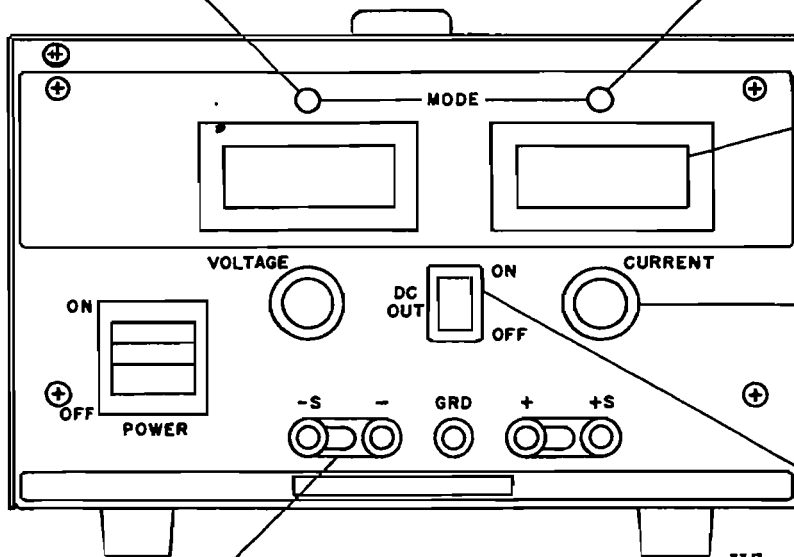

Current and voltage are indicated on the respective digital display.

Current and voltage are set on the respective control.

When this switch is OFF the voltage and current can be set to the desired crossover point. When the switch is then turned ON the unit will draw the amount of current determined by the load resistance. The current will not exceed the amount set on the current digital display. Voltage and current may also be adjusted when the unit is under load. See figure 2-2.

These links must remain in place unless remote sensing is employed.

FIGURE 1-1 CONTROLS AND INDICATORS.

SECTION II—INSTALLING AND USING THE MSK.

- 2-1 **UNPACKING AND INSTALLING:** Models of the MSK Series are shipped completely tested and ready for operation. Unpack the unit and save the packing materials. Inspect for visible damage. If damage is present, notify the shipping carrier.
- 2-2 The unit may be operated on a bench or any suitable flat surface, see Figure 2-3 for Outline Drawing. The tilting ball on the front bottom of the case elevates the unit to an angle for convenient viewing of the operating controls. Output and sense binding posts are provided at the front of the unit. Either the + or the - terminal may be connected or referred to ground.
- 2-3 The rear of the unit contains an input voltage selector switch. Set this switch to 115V or 230V position **before** connecting the unit to a power outlet: **Note: Also install the fuse as follows:**
For 115V a-c operation: Fuse slow blow, 3.15A-250V a-c, 5mm x 20mm; Kepco P/N 141-0104 or Schurter 034.3122.
For 230V a-c operation: Fuse slow blow, 1.6A-250V a-c, 5mm x 20mm; Kepco P/N 141-0108 or Schurter 034.3119.
- 2-4 Both current and voltage may be adjusted from zero to the maximum rated value. Refer to Section I for individual model current and voltage ranges. For any individual model the maximum rated value of voltage X current will equal approximately 100 Watts.
- 2-5 **THE PREVIEW FEATURE:** Test operations in the laboratory or shop often require that the unit under test be disconnected or power not applied until a preset constant current or constant voltage is applied. Also, the power source may be required to supply a range of preset fixed current or voltage upon demand.
- 2-6 Figure 1-1 shows the preview switch. Presettings may be made with this switch OFF. The value of preset voltage and current is adjusted with the precision controls and read on the respective digital displays. When the preview switch is ON the relation between voltage and current and the crossover point is shown in Figure 2-1. In a practical case the crossover point may not be sharp as shown but will be slightly rounded.

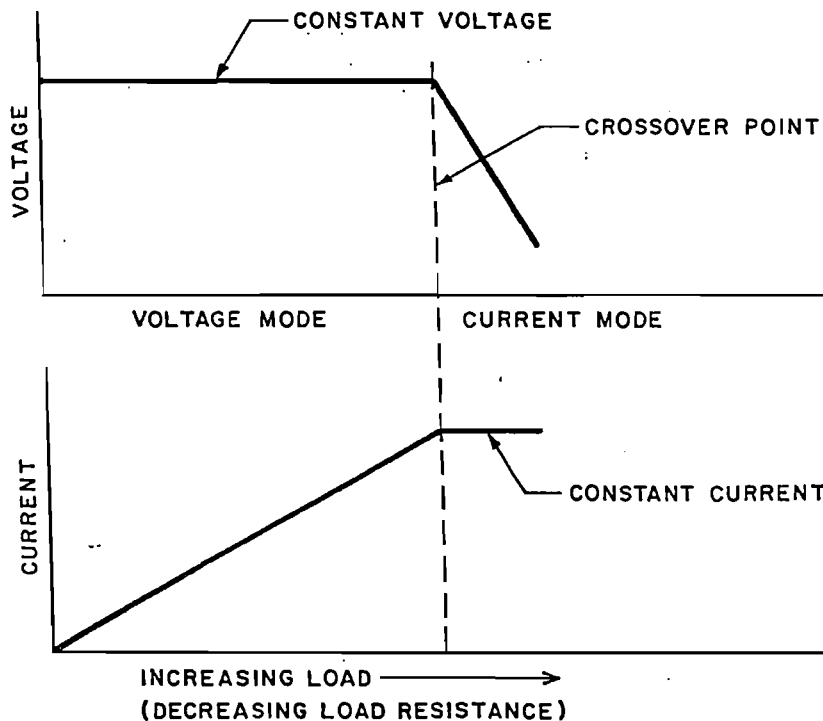

FIGURE 2-1 VOLTAGE AND CURRENT CROSSOVER.

2-7 Voltage and current may also be adjusted with the preview switch (load) ON. Voltage and current may be adjusted and observed on the digital displays and the behavior of the circuit under test may be observed.

2-8 For any given load the following rule applies:

When constant voltage is desired the current setting is increased so that the power supply operates **before** the crossover point. When constant current is desired the voltage setting is reduced so that the power supply operates **beyond** the crossover point.

2-9 The crossover point is given by the following relationship:

$$\text{Load Resistance} = \frac{\text{Preset Voltage}}{\text{Preset Current}}$$

2-10 **CROWBAR PROTECTION.** The MSK Series provides crowbar overvoltage protection. Any condition that causes an overvoltage at the output terminals will trigger an internal SCR circuit that shorts out the output terminals. The circuit will remain latched in this condition until the preview switch is moved to the OFF setting. If the condition is then removed power supply output resumes when the preview switch is returned to ON. Crowbar latching operates on an overvoltage transient of 2.5 milliseconds or more.

2-11 **ERROR SENSING.** The MSK Series employs binding posts for remote sensing of voltage error when operating in the voltage mode. The + S and - S binding posts are connected at the respective polarity at the load input. This corrects for voltage drop in the load connection leads.

2-12 The + S and - S binding posts must always remain connected to the output. When remote sensing is not employed the links should be in place as shown in Figure 1-1, Section I.

2-13 **CONNECTING LOADS.** In the **voltage** mode the power supply should exhibit zero impedance throughout its operating range. This requires that the impedance of the connecting wires between the power supply and the load should be as low as possible. In critical situations the connecting wires should be twisted and the external sensing leads should be shielded.

2-14 When operating in the **current** mode the power supply should exhibit a very high impedance throughout its operating range. In current mode the load wires should be shielded. When the current mode is of critical interest it is not necessary to employ external sensing at the load.

2-15 When more than one load is connected to the power supply the connection should be as shown in Figure 2-2.

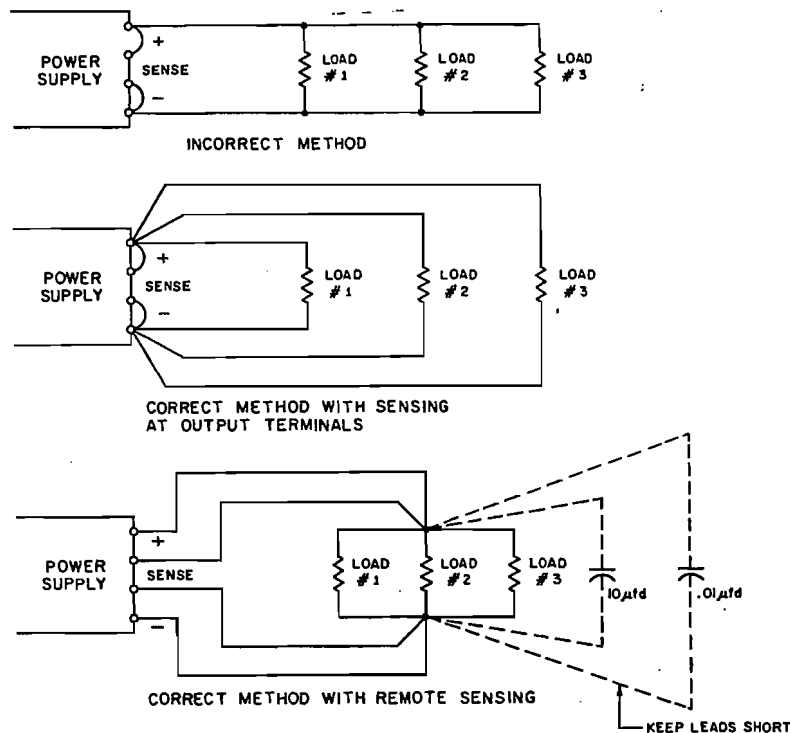

2-2 FIGURE 2-2 CORRECT AND INCORRECT METHODS OF CONNECTING MULTIPLE LOADS.

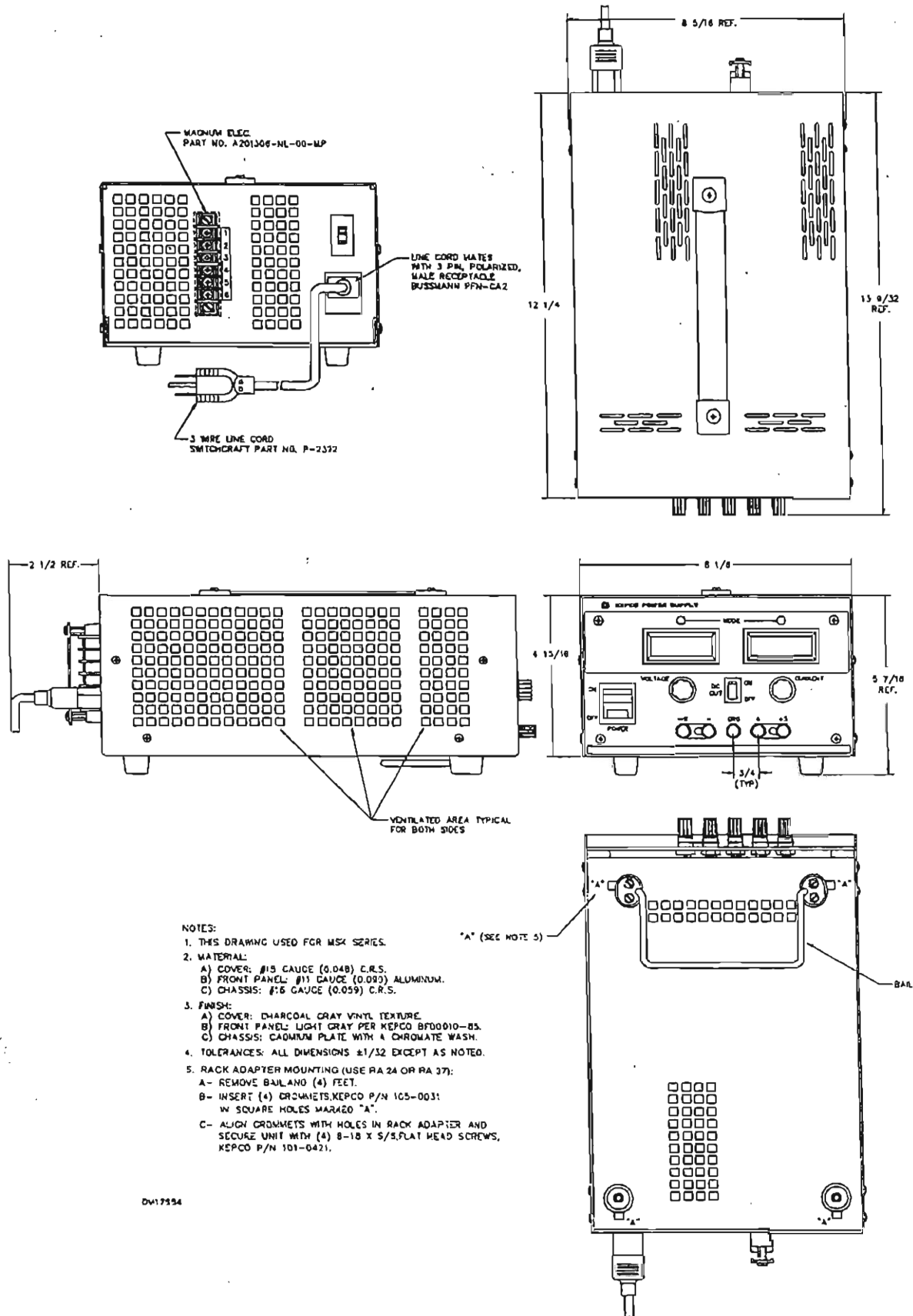

FIGURE 2-3. MECHANICAL OUTLINE

2-16 LOCAL/REMOTE PROGRAMMING:

For local front panel control of output voltage or current, terminals 2 & 3 and 4 & 5 on rear barrier strip TB201 are connected with links. (Standard factory setting).

For remote control of the output voltage, the link between 2 & 3 is removed, disabling the front panel voltage control. An external variable resistor of 10K ohm is connected by the user between terminals 1 & 3. The zero to 10K ohm variable resistance will remotely program the output voltage from zero to full scale.

For remote control of the output current by an external resistor, the link between 4 & 5 should be removed, disabling the front panel current control. An external variable resistor of 10K ohms is connected by the user between terminals 4 & 6. The zero to 10K ohm variable resistance will remotely program the output current from zero to full scale. To minimize the noise pick-up, use twisted shielded cables between the power supply programming terminals and the remote resistors.

SECTION III—THEORY OF OPERATION

- 3-1 GENERAL:** Kepco MSK power supplies are linear regulated units which employ pass transistors mounted on a heat sink. Voltage drop across the pass transistors maintains output voltage or current at preset levels. Drop across the pass transistors is regulated by linear circuitry which allows the output to be operated as either a constant current regulator or a constant voltage regulator. An accurately calibrated internal reference controls the voltage and current regulation. The voltage regulation channel is in control in the voltage mode until current reaches the value set on the front panel. At this point the current regulation channel takes over and the unit is in the current mode.
- 3-2** The following paragraph basically describes circuit operation. Refer to the simplified schematic, Figure 3-1 and the main schematic, Figure 5-1.
- 3-3 PHYSICAL LAYOUT:** Control circuitry of the unit is contained on the printed circuit board (A1 Control Assembly). The fan and transformer are mounted on Chassis Assembly A2. The pass transistors are mounted on Heat Sink Assembly A3. This arrangement allows easy access and replacement of assemblies.
- 3-4 POWER CIRCUITS:** Transformer A2T1 provides all circuit power. The transformer has a dual primary. The number of turns of the two primary winding sections is the same. When switch A2S1 is in the 115V a-c position both windings are in parallel. When the switch is in the 230V a-c position the two windings are in series and half of the input voltage appears across each winding. The fan is across one winding and will therefore have 115V a-c across it when the 115/230V selector is in either position.
- 3-5** Transformer A2T1 has two secondaries. Secondary winding W4 provides power for the control circuitry (op amps, etc.) and W3 provides output power. Bridge A1CR3 rectifies the voltage for the control circuitry. A1U1 and A1U2 are voltage regulators for the + 15V and - 15V required for the op-amp circuitry.
- 3-6** Zeners A1CR4 and A1CR5 provide + 5V and - 5V used to energize the digital displays. These voltages also provide bias for diodes A1CR9,10,11,12,13 and 14. The diodes act as clamps to protect the op-amps from transient stresses.
- 3-7** The main d-c power output is obtained from the full wave rectifier formed by A1CR1, A1CR2 located in heat sink assembly A3, and filter capacitor A2C1 mounted on chassis assembly A2. The filtered d-c is now regulated by the pass transistors as described in the following paragraph.
- 3-8 REFERENCE VOLTAGE:** Refer to Figure 3-1. All models of the series use zener A1CR6 as the standard voltage reference. This voltage is the input to op-amp A1U5-1 as shown. Potentiometer A1R9 is a feedback resistance that is set at the factory to calibrate the reference voltage for an individual unit. The output of A1U5-1 is a stable - 10 Volts that will be proportioned to values that are used for the individual models of the MSK Series which have different output characteristics.
- 3-9** The stable - 10 Volts reference is split into a voltage reference channel and a current reference channel. Op-amp A1U5-3 is the current reference channel. Resistor A1R13 is chosen with a different value for each model so that the individual voltage reference will be proportional to the full scale output voltage for the respective model. Resistor A1R12 is chosen with a different value for each model so that the individual voltage reference will be proportional to the full scale output current for the respective model.
- 3-10** When the preview switch is in the DC OFF position the panel meters directly read the value of both the voltage reference and the current reference, which are analogs of the preset values of voltage and current, respectively. The voltage and current controls on the panel control the feedback, hence, the gain A1U5-2 and A1U5-3, respectively. This adjusts the reference voltages so that the output of the unit will respond to the desired settings. This process is described in the following paragraphs.

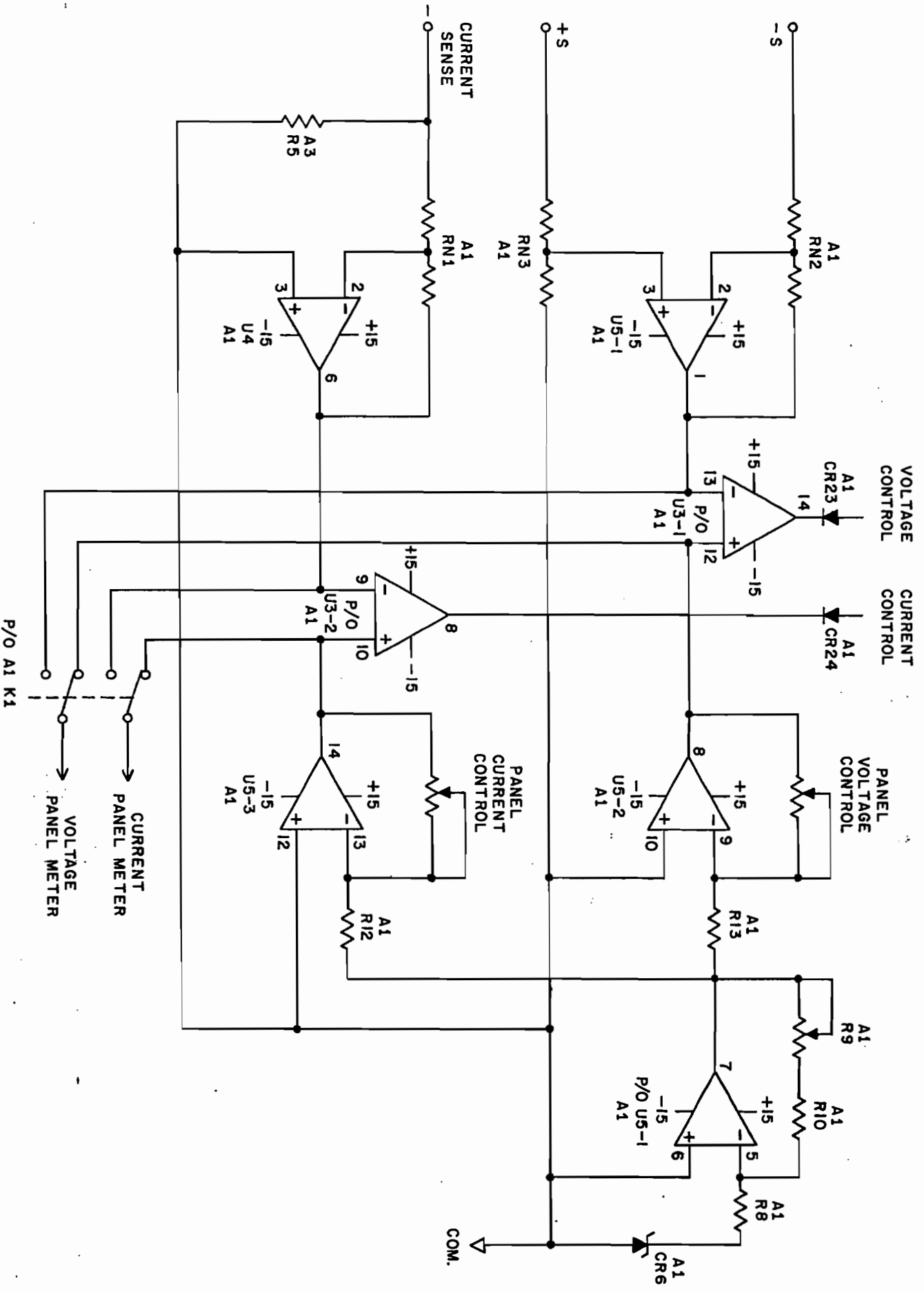

FIG. 3-1 SIMPLIFIED SCHEMATIC, VOLTAGE AND CURRENT CONTROL.

- 3-11 VOLTAGE CONTROL** is in effect only when the unit is in the voltage mode. The \pm voltage sense from the front panel is applied to A1U5-4 through the precision resistor network A1RN2 and A1RN3. The gain of A1U5-4 is therefore a constant value in proper proportion to the reference. Op-amp A1U3-1 is a comparator that compares the sense voltage with the reference voltage that has been preset as explained in the preceding paragraph. This voltage is applied degeneratively to the drivers in the heat sink which cause the drop across the pass transistors to constantly react to bring the output voltage to a value that reduces the difference between the reference voltage and the sense voltage to zero. Hence, output voltage is stabilized.
- 3-12 CURRENT CONTROL** is in effect only when the unit is in the current mode. Current is sensed by the voltage drop in A3R5 in the heat sink which is in series with the load. The current sense voltage is applied to A1U4 through resistor network A1RN1. The gain of A1U4 is therefore a constant value in proper proportion to the current reference voltage. Op-amp A1U3-2 is a comparator that compares the current sense voltage with the reference voltage. Output voltage of the comparator will always be the difference between the two voltages. If the unit is in the current mode this voltage is applied degeneratively to the drivers in the heat sink which cause the drop across the pass transistors to constantly react to bring the output current to a value that reduces the difference between the reference voltage and the current sense voltage to zero. Hence, output current is stabilized.
- 3-13 MODE CONTROL AND PREVIEW** Relay A1K1 is deenergized in the DC OFF (preview) position. When the preview switch is OFF, both output voltage and current are programmed to zero via A1U3-3 and A1U3-4, thus disconnecting the load from the output terminals. Also, the panel meters are directly connected to read the value of both the voltage reference and the current reference, which are analogs of the preset values of voltage and current as previously mentioned. When the preview switch is ON the panel meters are connected to the current and voltage sense voltages. They will therefore read the sensed values of voltage and current.
- 3-14** The mode crossover characteristic is discussed in Section II. Mode control circuitry (not shown on the simplified schematic) causes the mode to cross over when current goes above or below the preset value. When the unit is in the voltage mode the output voltage comparator controls the pass elements to cause voltage to remain constant. When the load resistance is such that current exceeds the preset value the crossover circuitry places the current comparator in control of the pass elements.
- 3-15 PASS ELEMENTS:** Output is maintained at a constant voltage or current level by the NPN silicon pass transistor assembly which is in series with the output. Model MSK 125-1M, which produces a higher output voltage, uses two sets of pass transistors which are in series. All other models use a single set of pass transistors in series. The pass transistors are located on a specially constructed fan-cooled heat sink (A3). The series resistance of the pass transistors produces a voltage drop which is controlled by their base voltage. The base voltage is supplied by driver transistor A3Q5. Driver A3Q5 is controlled by the regulation circuits previously described. When the unit is in the voltage mode the pass resistance is a function of output sense voltage. In the current mode the pass transistors maintain a constant current regardless of load or variations of the input supply.
- 3-16 OVERVOLTAGE PROTECTION** is provided by A1U6 and A1U7. Overvoltage appears at pin 1 of A1U7. The effect of an overvoltage is to trigger triac A1CR17 which interrupts the output and shorts the output terminals of the unit. Capacitor A1C7 at pin 2 of A1U7 determines the delay length of overvoltage spike which will trigger A1CR17. The value of A1C7 prevents the unit from overvoltage triggering on short noise spikes. When A1U7 detects overvoltage and triggers A1CR17 it also latches SCR A1CR29. This causes the output to go to a very low value. The overall effect is to cause the output impedance of the unit to appear as a short circuit, protecting the load. Output can only be restored by removing the cause of overvoltage and turning the unit OFF, then back ON.

SECTION IV—MAINTENANCE, TESTING AND TROUBLESHOOTING

- 4-1 GENERAL:** This section covers the techniques of maintenance, testing and troubleshooting of the MSK Series. The material covered in this section is for the use of maintenance personnel equipped with instruments capable of testing d-c power devices within the range of load typical of the MSK Series.
- 4-2** The MSK Series is capable of operating for long periods within the specified environment. Periodic maintenance is not required except in unusual environment which may cause physical deterioration. In this case periodic inspection and cleaning may be appropriate. No internal or external service adjustment is required.
- 4-3 MEASURING CHARACTERISTICS:** Models of the MSK Series are stable power supplies. The measured characteristics of stabilized power supplies are as follows: load effect, source effect, temperature effect, drift, and ripple and noise.
- 4-4** A power supply which has the foregoing characteristics within the specified range may be considered to be performing properly. The specified range for each of these characteristics is given in Section I of this manual. It is usually not possible to measure all of these characteristics at the repair shop level, since this requires laboratory instrumentation and considerable shop time.
- 4-5 LOAD EFFECT** measures the ability of the unit to maintain constant voltage output with variable load throughout a range from zero to its specified nominal (maximum) value. For shop testing, when the load effect is within specified range it usually indicates that a unit is performing satisfactorily.
- 4-6 SOURCE EFFECT** measures the ability of the unit to respond to a specified range of input voltage variation while maintaining its output within specified range. At the repair shop level it is usually only necessary to vary the input voltage within specified range and note that output remains within limits.
- 4-7 TEMPERATURE EFFECT** measures the ability of the unit to maintain proper output over a specified range of temperature. MSK units are rated from 0°C to 55°C. This characteristic is usually not measured at the repair shop level.
- 4-8 DRIFT** measures the ability of the unit over a given time to maintain the load, source, temperature effect and ripple and noise, within the specified limits. In the repair shop it is usually only necessary to place the unit under operating load and allow it to operate for a period of time, then to check voltage regulation by any simple means.
- 4-9 RIPPLE AND NOISE:** are specified as peak-to-peak in millivolts. Ripple frequency components are related to the input (source) frequency. Noise occupies a wide spectrum that ordinarily has no outstanding frequency component. The presence of noise above the specified value is an indication of trouble. Likewise the presence of high ripple frequency components related to source frequency is an indication of unsatisfactory operation.
- 4-10 TEST SET UP FOR MEASURING CHARACTERISTICS AND TROUBLESHOOTING.**
- 4-11** When making tests in voltage mode with the methods just described it must be taken into account that in a real system application the load may be at a location remote from the power supply. Remote sensing would then be preferred.
- 4-12** In the current mode the output of the units respond as an infinite impedance. Other than to assure that a unit maintains uniform current in the current mode as the load varies within the specified range, no other test is required.
- 4-13** The load resistor simulates an actual load. It must be capable of sustaining the power and current range of the unit. Measuring current in heavy current devices requires special care. There will always be a certain amount of voltage drop across any current measuring device. An ammeter actually measures current by measuring the voltage across its internal resistance. Current is then indicated as a function of Ohm's law. Moreover, current flowing through the resistance causes heating which increases the resistance. To prevent heating effect, the resistance employed to measure current should be as small as possible and composed of resistance wire as heavy as practical. Although the voltage drop across the wire may then be small, it can be measured with an accurate digital voltmeter. When an ammeter is used it should be made part of the load. This takes into consideration the full voltage output of the power supply by allowing for drop through the ammeter.

4-14 MEASURING LOAD EFFECT

4-15 Measure load effect as follows:

- a) Make the test set up as shown in Figure 4-1
- b) Record output with no load
- c) Set the load for nominal value (refer to Section I)
- d) Record the output voltage.
- e) Compute the load effect as follows:

$$\text{Load effect} = \frac{\text{Voltage Difference}}{\text{Specified Nominal Voltage}}$$

The specified load effect is given in unit specifications. Higher values than this indicates unsatisfactory operation.

4-16 MEASURING RIPPLE AND NOISE

4-17 Ripple and Noise are measured at the nominal load. The important safeguard in testing is to minimize the impedance between power supply output and load, or at least to measure the voltage characteristics so as to prevent the spurious voltages from this impedance from appearing in the measurement. All circuit elements must be brought to a common ground point. The test equipment must be isolated from the a-c lines. All test leads should be shielded. The connection to the load must be twisted to minimize inductive effects.

4-18 For shop testing the best hook-up is to place the load directly on the output terminals and consider everything appearing beyond the output terminals as load. A means of isolating the measuring equipment from the power mains must be used if the isolation rating of the test equipment is inadequate.

4-19 TROUBLESHOOTING

NOTE: All troubleshooting should be done with the output and sense leads linked together.

4-20 Follow these rules in troubleshooting circuits:

- a) A failed resistor causes an open circuit.
- b) A failed capacitor usually causes a short circuit.
- c) Look for physical signs such as scorched areas, cracks and contamination.

4-21 The following preliminary basic steps in localizing trouble should be followed:

- a) If the unit fails to show any operational signs, check obvious points such as a-c input connections and fuse.
- b) Check the current control. Turn the control clockwise to its maximum position.
- c) Check the unit internally for interconnection of circuit boards and components.
- d) Make a voltage check of points on the circuits.

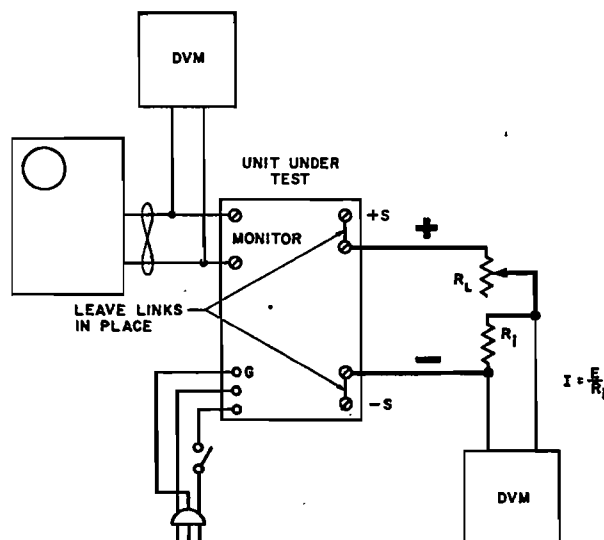

4-22 RESISTOR R9 ALIGNMENT

1. Switch OFF the POWER switch on unit under test. Place a short across the MSK output terminals.
2. Switch ON the DC OUT switch on unit under test.
3. Switch ON the POWER switch on unit under test. The CURRENT MODE LED should be energized.
4. Slowly turn the CURRENT control clockwise and observe the gradual increase in output reading. The maximum value must be within the range of Table 1. If not adjust R9 to get the appropriate current reading equal to the lowest value of the current range.
5. Switch OFF the POWER switch on unit under test. Remove the short circuit across the MSK output terminals
6. Switch ON the POWER switch on unit under test. The VOLTAGE MODE LED should be energized
7. Slowly turn the VOLTAGE control clockwise and observe the gradual increase in output reading. The maximum value must be within the range of Table 1. If not adjust R9 to get the appropriate voltage reading equal to the lowest value of the voltage range.
8. Repeat the above tests to check that the maximum current value is within the range indicated in Table 1.

Table 4-1. Output Ratings of MSK Power Supplies

MSK SERIES	MSK 10-10M	MSK 20-5M	MSK 40-2.5M	MSK 60-2M	MSK125-1M
VOLTAGE METER Maximum Values (Vdc)	11-12.5	21-25	41-47	61-71	126-142
CURRENT METER Maximum Values (Adc)	10.1-10.4	5.05-5.4	2.53-2.75	2.02-2.2	1.01-1.15

SECTION V—ELECTRICAL PARTS LIST AND DIAGRAMS

5-1 GENERAL

- 5-2 This section contains the main schematic, the parts location diagrams, and a list of all replaceable electrical parts. All components are listed in alpha-numerical order of their reference designations. Consult your Kepco Representative for replacement of parts not listed here.

5-3 ORDERING INFORMATION

- 5-4 To order a replacement part or to inquire about parts not listed in the parts list, address order or inquiry either to your authorized Kepco Sales Representative or to:

KEPCO, INC.
131-38 Sanford Avenue
Flushing, N.Y. 11352

- 5-5 Specify the following information for each part:

- a) Model and complete serial number of instrument.
- b) Kepco part number.
- c) Circuit reference designator.
- d) Description.

- 5-6 To order a part not listed in the parts list, give a complete description and include its function and location.



KEPCO. REPLACEMENT PARTS LIST

MSK SERIES

COMMON PARTS LIST ASSEMBLY (A1)

Code 03-0301

REFERENCE DESIGNATION	QTY.	DESCRIPTION	MFRS. NAME & PART NO. SEE BOTTOM NOTE	KEPCO PART NO.	REC. SPARE PART QTY.
C1		See Individual Parts List			
C2,3	2	Cap., Elect., Radial Leads 330 μ F, 20%, 35V	United Chemi-Con SME35VB331M10X16LL	117-1012	1
C4,5	2	Cap., Elect., Radial Leads 2.2 μ F, 20%, 50V	United Chemi-Con Type KMC	117-0878	1
C6,9,22	3	Cap., Elect., Tantalum, Ax. Lds. 1 μ F, 20%, 50V	Sprague Type 162D	117-0815	1
C7	1	Cap., Film, Ax. Leads 0.5 μ F, 10%, 200V	Wescon Type 33MM	117-0123	1
C8	1	Cap., Film, Ax. Leads 0.01 μ F, 20%, 200V	Sprague Type 192P	117-0353	1
C10,11,12, 13,26		Not Used			
C14		See Individual Parts List			
C15,16	2	Cap., Elect., Radial Leads 100 μ F, 20%, 25V	United Chemi-Con Type SMC	117-1005	1
C17	1	Cap., Monolithic, Ceramic 0.1 μ F, 20%, 50V	Kemet Type C320C	117-0967	1
C18,19		Not Used			
C20,21,24,25		See Individual Parts List			
C23	1	Cap., Ceramic Monolithic 0.1 μ F, 20%, 100V	Kemet Type C330	117-0990	1
CR1,2,7, 8,19	5	See Individual Parts List			
CR3	1	Rect., Bridge 200V (PIV), 1A	General Instruments Type W-02	124-0346	1
CR4,5	2	Diode, Zener, Ax. Leads 5.1V, 5%, 1/2W	Motorola 1N52318	121-0084	1
CR6	1	Diode, Zener, Ax. Leads 6.2V, 5%, 0.4W	Motorola 1N827	121-0062	1
CR9 thru 14 21 thru 25	11	Switching, Diode 75V PIV, 1A, 0.4W	AM Power Devices 1N4148	124-0437	1
CR15,16	2	Rect., Diode 100V PIV, If = 50 μ A@0.5V	Semicon Type HVP	124-0178	1
CR17	1	Thyristor, Triac, TO-220 200V, 12A	Motorola 2N6342A	124-0568	1
CR18		See Individual Parts List			
CR20	1	Diode, Rect., Si. 400V PIV, 5A	Semicon Inc. Type S-5A4	124-0348	1
CR26,27		Not Used			

5-3/5-4

NOTE: REPLACEMENT PARTS MAY BE ORDERED FROM KEPCO, INC. ORDERS SHOULD INCLUDE KEPCO PART NUMBER AND DESCRIPTION.

PLEASE NOTE: THE MANUFACTURER'S NAME AND PART NUMBER LISTED FOR EACH ITEM ON REPLACEMENT PARTS LISTS REPRESENTS AT LEAST ONE SOURCE FOR THAT ITEM AND IS LISTED SOLELY FOR THE CONVENIENCE OF KEPCO EQUIPMENT OWNERS IN OBTAINING REPLACEMENT PARTS LOCALLY. WE RESERVE THE RIGHT TO USE EQUIVALENT ITEMS FROM ALTERNATE SOURCES. KEPCO, INC.



KEPCO. REPLACEMENT PARTS LIST

MSK SERIES

COMMON PARTS LIST ASSEMBLY (A1)

Code 07-1888

REFERENCE DESIGNATION	QTY.	DESCRIPTION	MFRS. NAME & PART NO. SEE BOTTOM NOTE	KEPCO PART NO.	REC. SPARE PART QTY.
CR28	1	Diode, Stablistor $V_f = 1.30V$ min@ $I_f = 10mA$, 400mW	AM Power Devices APD203	124-0435	6
CR29	1	SCR, PNP, TO-92 30V, 0.8A	Motorola 2N5060	124-0429	1
K1	1	PC Mount DC Relay 4 PDT, 12V, 2A	Aromat NF4EB-12V	140-0101	1
Q1		See Individual Parts List			
Q2	1	Transistor, Si., NPN Low Power, TO-5	RCA 2N3053	119-0059	1
R1,2	2	Res., Fxd., Molded 22K ohm, 10%, 1/4W	Allen Bradley CB2231	115-2458	1
R3,16,19	3	Res., Fxd., Molded 100 ohm, 10%, 1/4W	Allen Bradley CB1011	115-2231	1
R4,14	2	Res., Fxd., Molded 10K ohm, 10%, 1/4W	Allen Bradley CB1031	115-2211	1
R5,6,7,18, 31,32,38,40,41	9	Res., Fxd., Molded 1K ohm, 10%, 1/4W	Allen Bradley CB1021	115-2238	1
R8,20,27	3	Res., Fxd., Metal Film 1K ohm, 1%, 1/8W	Dale Type RN55D	115-2180	1
R9	1	Res., Var., Cermet 1K ohm, 10%, .75W @75°C	Bourns Type 3009-P	115-2456	1
R10	1	Res., Fxd., Metal Film 5.62K ohm, 1%, 1/8W	Dale Type RN55D	115-2409	1
R11	1	Res., Fxd., Metal Film 10K ohm, 1%, 1/8W	Dale Type RN55D	115-2174	1
R12,13		See Individual Parts List			
R15,17		Not Used			
R21,22,23, 26,33		See Individual Parts List			
R24	1	Res., Fxd., Molded 82 ohm, 10%, 1/4W	Allen Bradley CB8201	115-2495	1
R25,28,30,34		Not Used			
R29	1	Res., Fxd., Molded 15K ohm, 10%, 1/4W	Allen Bradley CB1531	115-2497	1
R35	1	Res., Fxd., Molded 3.9 ohm, 5%, 1/4W	Allen Bradley CB3905	115-2715	1
R36	1	Res., Fxd., Molded 1.5K ohm, 10%, 1/4W	Allen Bradley CB1521	115-2229	1
R37	1	Res., Fxd., Molded 680 ohm, 10%, 1/2W	Allen Bradley CB6811	115-0558	1
R39	1	Res., Fxd., Molded 4.7K ohm, 10%, 1/4W	Allen Bradley CB4721	115-2383	1
RN1,2,3		See Individual Parts List			
RN4,5	2	Res., Network, 2 units 99K ohm/1K ohm, 1%	Kepeco Inc. 234-0036	234-0036	1

5-5/5-6

NOTE: REPLACEMENT PARTS MAY BE ORDERED FROM KEPCO, INC. ORDERS SHOULD INCLUDE KEPCO PART NUMBER AND DESCRIPTION.

PLEASE NOTE: THE MANUFACTURER'S NAME AND PART NUMBER LISTED FOR EACH ITEM ON REPLACEMENT PARTS LISTS REPRESENTS AT LEAST ONE SOURCE FOR THAT ITEM AND IS LISTED SOLELY FOR THE CONVENIENCE OF KEPCO EQUIPMENT OWNERS IN OBTAINING REPLACEMENT PARTS LOCALLY. WE RESERVE THE RIGHT TO USE EQUIVALENT ITEMS FROM ALTERNATE SOURCES.	KEPCO, INC.
---	-------------



KEPCO. REPLACEMENT PARTS LIST

MSK SERIES

COMMON PARTS LIST ASSEMBLY (A1)

Code 07-1888

REFERENCE DESIGNATION	QTY.	DESCRIPTION	MFRS. NAME & PART NO. SEE BOTTOM NOTE	KEPCO PART NO.	REC. SPARE PART QTY.
U1	1	IC, Voltage Reg., Positive 15V, 0.5A, TO-220	Fairchild μ A78M15UC	250-0084	1
U2	1	IC, Voltage Reg., Negative 15V, 0.5A, TO-220	Fairchild μ A79M15AVC	250-0065	1
U3,5	2	IC, Quad, Op. Amp., 324 Type 14 Pin-Dip	National LM324N	250-0050	1
U4	1	IC, Op., Amp. 8 Pin-Dip, Plastic	Prec. Monolithic OP-07CP	250-0148	1
U6	1	IC, Dual Comparator 8 Pin-Dip, Plastic	Texas Instruments LM393P	250-0098	1
U7	1	IC, Overvoltage, Crowbar 8 Pin-Dip, Plastic	Motorola MC3425PI	250-0192	1

5-715-8

NOTE: REPLACEMENT PARTS MAY BE ORDERED FROM KEPCO, INC. ORDERS SHOULD INCLUDE KEPCO PART NUMBER AND DESCRIPTION.

PLEASE NOTE: THE MANUFACTURER'S NAME AND PART NUMBER LISTED FOR EACH ITEM ON REPLACEMENT PARTS LISTS REPRESENTS AT LEAST ONE SOURCE FOR THAT ITEM AND IS LISTED SOLELY FOR THE CONVENIENCE OF KEPCO EQUIPMENT OWNERS IN OBTAINING REPLACEMENT PARTS LOCALLY. WE RESERVE THE RIGHT TO USE EQUIVALENT ITEMS FROM ALTERNATE SOURCES. KEPCO, INC.



REPLACEMENT PARTS LIST

MSK SERIES

COMMON PARTS LIST CHASSIS ASSEMBLY, A2

Code 10-1300

REFERENCE DESIGNATION	QTY	DESCRIPTION	MFRS. NAME & PARTS NO. SEE BOTTOM NOTE	KEPCO PART NO.	REC. SPARE PART QTY.
B1	1	Fan Motor 115V a-c 50/60 Hz	Kepco Inc. 148-0050	148-0050	1
C1		See Individual Parts List			
F1	1	Fuse, Slow Blow, 5x20mm 3.15 Amps, 250V	Schurter 034.3122	141-0104	1
R1,2,3,4		See Individual Parts List			
S1	1	Line Voltage, Select Switch 115-230V a-c	ITW Switches 18-000-0040	127-0395	1
T1		See Individual Parts List			

COMMON PARTS LIST PASS ASSEMBLY, A3

C1,2	2	Cap., Film, Ax. Leads 0.5 μ F, 10%, 200V	Wescon Type 33MM	117-0123	1
C4	1	See Individual Parts List			
CR1,2,3,4		See Individual Parts List			
Q1 thru Q6		See Individual Parts List			
R1,2,3,4,5		See Individual Parts List			
R6	1	Res., Fxd., Molded 100 ohm, 10%, 1/4W	Allen Bradley CB1010	115-2231	1
R7	1	Res., Fxd., Molded 470 ohm, 10%, 1/4W	Allen Bradley CB4711	115-2235	1
R8		See Individual Parts List			
R9,10,11,12		See Individual Parts List			

5-9/5-10

NOTE: REPLACEMENT PARTS MAY BE ORDERED FROM KEPCO, INC. ORDERS SHOULD INCLUDE KEPCO PART NUMBER AND DESCRIPTION.

PLEASE NOTE: THE MANUFACTURER'S NAME AND PART NUMBER LISTED FOR EACH ITEM ON REPLACEMENT PARTS LISTS REPRESENTS AT LEAST ONE SOURCE FOR THAT ITEM AND IS LISTED SOLELY FOR THE CONVENIENCE OF KEPCO EQUIPMENT OWNERS IN OBTAINING REPLACEMENT PARTS LOCALLY. WE RESERVE THE RIGHT TO USE EQUIVALENT ITEMS FROM ALTERNATE SOURCES. KEPCO, INC.



REPLACEMENT PARTS LIST

MSK SERIES

COMMON PARTS LIST FRONT PANEL ASSEMBLY (A4)

Code 10-1700

REFERENCE DESIGNATION	QTY.	DESCRIPTION	MFRS. NAME & PARTS NO. SEE BOTTOM NOTE	KEPCO PART NO.	REC. SPARE PART QTY.
DS1,2	2	LCD Digital Panel Meter 200mV, 3 1/2 digits	Kepco, Inc. 135-0574	135-0574	1
DS3	1	LED, Green 3V, 20mA	IDI 5210F-5	153-0080	1
DS4	1	LED, Yellow 3V, 20mA	IDI 5210F-7	153-0081	1
R1,2	2	Res., Var., Multi-turn, W.W. 10K ohm, 5%, 2W	Spectrol Type 534	115-1234	1
S1	1	Switch, DPST 125V a-c, 10A/5A, 250V a-c	Kepco Inc. 127-0371	127-0371	1
S2	1	Switch Rocket, SPDT .4VA max. @ 20V	Kepco Inc. 127-0396	127-0396	1
MISCELLANEOUS					
N.A.	1	Line Cord	Kepco Inc. 118-0552	118-0552	
N.A.	1	Retractable Bail, for mounting on 5 1/2"	Kepco Inc. 139-0231	139-0231	
N.A.	1	Handle	Kepco Inc. 139-0215	139-0215	
N.A.	1	Fan Blade, 4" dia.	Kepco Inc. 149-0035	149-0035	
N.A.	2	Binding Post, Black	Kepco Inc. 151-0026	151-0026	
N.A.	1	Binding Post, Green	Kepco Inc. 151-0048	151-0048	
N.A.	2	Binding Post, Red	Kepco Inc. 151-0025	151-0025	
N.A.	2	Knob	Kepco Inc. 155-0052	155-0052	
N.A.	1	Bail Mounting Foot, Left	Kepco Inc. 158-0005	158-0005	
N.A.	1	Bail Mounting Foot, Right	Kepco Inc. 158-0006	158-0006	
N.A.	2	Foot	Kepco Inc. 158-0007	158-0007	
J1	1	Fused Power Inlet	Kepco Inc. 143-0357	143-0357	
TB201	1	Barrier Strip	Kepco, Inc. 167-0882	167-0882	
N.A.	2	Link	Kepco, Inc. 172-0306	172-0306	

5-11/5-12

NOTE: REPLACEMENT PARTS MAY BE ORDERED FROM KEPSCO, INC. ORDERS SHOULD INCLUDE KEPSCO PART NUMBER AND DESCRIPTION.

PLEASE NOTE: THE MANUFACTURER'S NAME AND PART NUMBER LISTED FOR EACH ITEM ON REPLACEMENT PARTS LISTS REPRESENTS AT LEAST ONE SOURCE FOR THAT ITEM AND IS LISTED SOLELY FOR THE CONVENIENCE OF KEPSCO EQUIPMENT OWNERS IN OBTAINING REPLACEMENT PARTS LOCALLY. WE RESERVE THE RIGHT TO USE EQUIVALENT ITEMS FROM ALTERNATE SOURCES. KEPSCO, INC.



KEPCO. REPLACEMENT PARTS LIST

MSK 40-2.5M

INDIVIDUAL PARTS LIST, CONTROL ASSEMBLY (A1)

Code 11-0488

REFERENCE DESIGNATION	QTY.	DESCRIPTION	MFRS. NAME & PART NO. SEE BOTTOM NOTE	KEPCO PART NO.	REC. SPARE PART QTY.
C1,14	2	Cap., Elect., Radial Leads 100 μ F, 20%, 100V	United Chemi-Con Type SMC	117-1002	1
C20	1	Cap., Ceramic Disc 680pF., 20%, 3KV	Centralab DD30-681	117-0587	1
C21,25	2	Cap., Ceramic, Ax. Leads 0.047 μ F., 10%, 200V	Sprague Type 192P	117-0362	1
C24	1	Cap., Film, Ax. Leads 560pF, 10%, 200V	AVX Corp. SA102C561KAA	117-1083	1
CR1,2	2	Diode, Rect., Ax. Leads 400V (PIV), 1A	Semicon Inc. Type Si-4	124-0028	1
CR7,8,19	3	Diode, Rect., Axial Leads 100V (PIV), 1A	Semicon Inc. Type Si-1	124-0133	1
CR18		Not Used			
Q1		Not Used			
R12	1	Res., Fxd., Metal Film 40.2K ohm, 1%, $\frac{1}{8}$ W	Dale Type RN55D	115-2761	1
R13	1	Res., Fxd., Metal Film 24.3K ohm, 1%, $\frac{1}{8}$ W	Dale Type RN55D	115-2451	1
R21,26	2	Res., Fxd., Metal Film 75K ohm, 1%, $\frac{1}{4}$ W	Dale Type RN60D	115-2584	1
R22,23		Not Used			
R33	1	Res., Fxd., Molded 51K ohm, 5%, $\frac{1}{4}$ W	Allen Bradley CB5131	115-2767	1
RN1	1	Res., Network, 2 units 25K/10K ohm, 1%	Kepco, Inc. 234-0011	234-0011	1
RN2,3	2	Res., Network, 2 units 10K/1K ohm, 1%,	Kepco, Inc. 234-0007	234-0007	1

INDIVIDUAL PARTS LIST, CHASSIS ASSEMBLY (A2)

C1	1	Cap., Elect., Can-Type 7800 μ F, +75 - 10%, 75V	Mepco/Electric Type 3816	117-0997	1
R1	1	Res., Fxd., Molded 4.7K ohm, 10%, 2W	Allen Bradley HB4721	115-0056	1
R2,3	2	Res., Fxd., Power, Ax. Leads 1.5K ohm, 5%, 20W	Ward Leonard 20S1500	115-0923	1
R4		Not Used			
T1	1	Transformer Power	Kepco, Inc. 100-2251	100-2251	1

5-13/5-14

NOTE: REPLACEMENT PARTS MAY BE ORDERED FROM KEPCO, INC. ORDERS SHOULD INCLUDE KEPCO PART NUMBER AND DESCRIPTION.

PLEASE NOTE: THE MANUFACTURER'S NAME AND PART NUMBER LISTED FOR EACH ITEM ON REPLACEMENT PARTS LISTS REPRESENTS AT LEAST ONE SOURCE FOR THAT ITEM AND IS LISTED SOLELY FOR THE CONVENIENCE OF KEPCO EQUIPMENT OWNERS IN OBTAINING REPLACEMENT PARTS LOCALLY. WE RESERVE THE RIGHT TO USE EQUIVALENT ITEMS FROM ALTERNATE SOURCES.	KEPCO, INC.
---	-------------



REPLACEMENT PARTS LIST

MSK 40-2.5M

INDIVIDUAL PARTS LIST, PASS ASSEMBLY (A3)

Code 12-0401

REFERENCE DESIGNATION	QTY	DESCRIPTION	MFRS. NAME & PARTS NO. SEE BOTTOM NOTE	KEPCO PART NO.	REC. SPARE PART QTY.
CR1,2	2	Diode Rect., Axial Leads 400V (PIV), 5A	Kepeco Inc. 124-0348	148-0026	1
CR3,4		Not Used			
Q1 thru Q4	4	Transistor, Si., NPN Power TO-3	Kepeco Inc. 119-0061	119-0061	1
Q5	1	Transistor, Si., NPN Med., Power, TO-66	RCA 2N3054	119-0060	1
Q6	1	Not Used			
R1,2,3,4	4	Res., Fxd., Power, Ax. Leads 0.8 ohm, 3%, 3W	Tepro Type TS3	115-2460	1
R5	1	Res., Kelvin, 4-term., W.W. 0.4 ohm, 0.1%, 5W	Tepro Type TSK	115-2758	1
R9,11,12		Not Used			

5-15/5-16

NOTE: REPLACEMENT PARTS MAY BE ORDERED FROM KEPCO, INC. ORDERS SHOULD INCLUDE KEPCO PART NUMBER AND DESCRIPTION.

PLEASE NOTE: THE MANUFACTURER'S NAME AND PART NUMBER LISTED FOR EACH ITEM ON REPLACEMENT PARTS LISTS REPRESENTS AT LEAST ONE SOURCE FOR THAT ITEM AND IS LISTED SOLELY FOR THE CONVENIENCE OF KEPCO EQUIPMENT OWNERS IN OBTAINING REPLACEMENT PARTS LOCALLY. WE RESERVE THE RIGHT TO USE EQUIVALENT ITEMS FROM ALTERNATE SOURCES. KEPCO, INC.

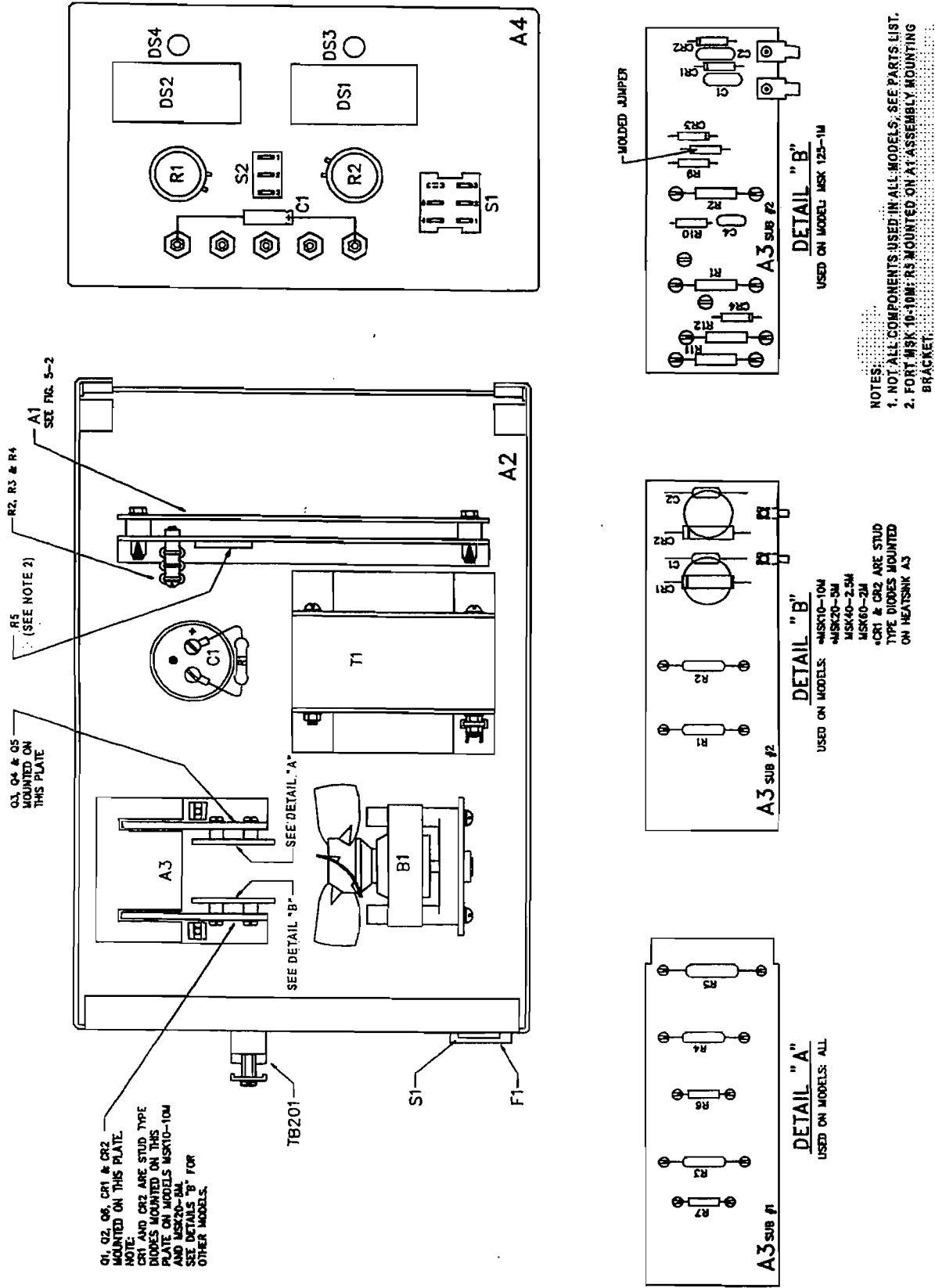
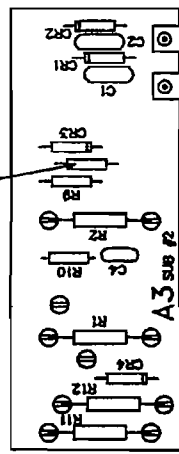
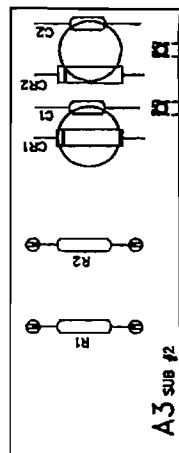
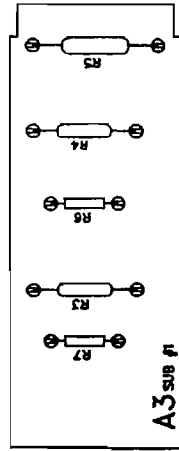

FIGURE 5-1 COMPONENT LOCATION (A2), MAIN CHASSIS ASSEMBLY WITH FRONT PANEL (A4) AND HEAT SINK ASSEMBLY (A3)

NOTES:
 1. NOT ALL COMPONENTS USED IN ALL MODELS; SEE PARTS LIST.
 2. FORT MSK 10-10M; R3 MOUNTED ON A1 ASSEMBLY MOUNTING BRACKET.



DETAIL "A"
 USED ON MODELS: ALL

DETAIL "B"
 USED ON MODELS: MSK10-10M
 MSK20-2M
 MSK40-2M

DETAIL "B"
 USED ON MODEL: MSK 125-1M

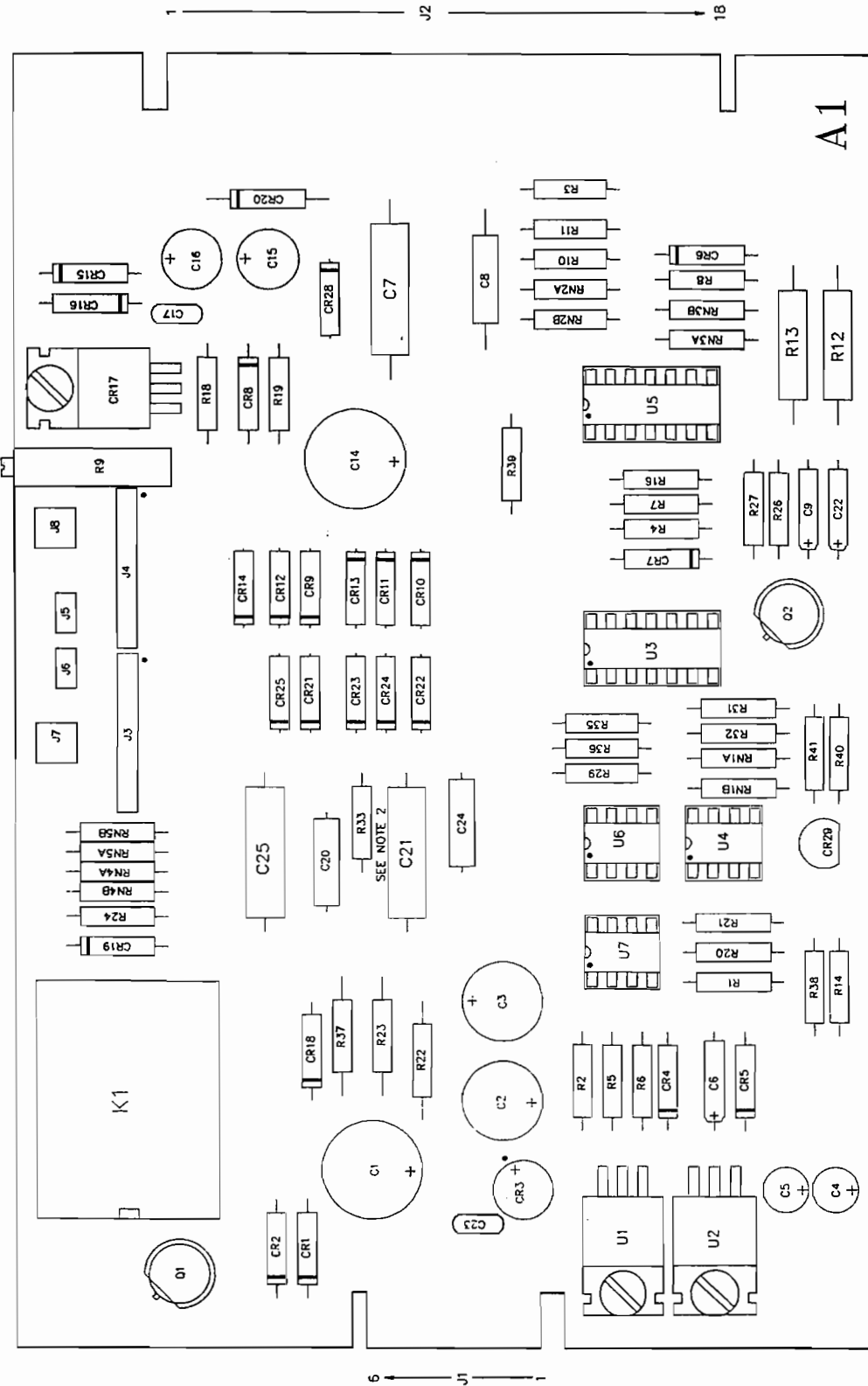

NOTES:
 1. NOT ALL COMPONENTS USED IN ALL MODELS. SEE PARTS LIST.
 2. R33 USED ONLY IN MODEL MSK 40-2.5M, ON ALL OTHER MODELS R33 IS REPLACED WITH A MOLDED JUMPER.

FIGURE 5-2 COMPONENT LOCATION, CONTROL ASSEMBLY (A1)

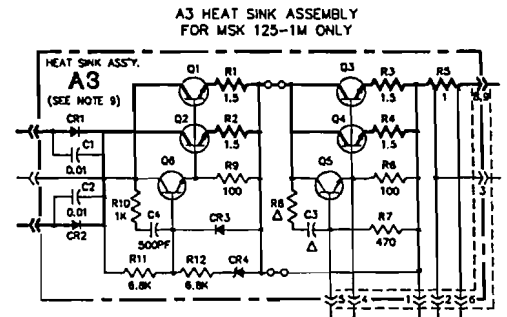

- NOTES:**
1. NOT ALL COMPONENTS IN ALL MODELS. FOR VALUES OF COMPONENTS MARKED "Δ" SEE PARTS LIST.
 2. DC INPUT VOLTAGE (E_I) AND OUTPUT VOLTAGE (E_O) ARE LISTED FOR EACH MODEL (SEE TABLE).
 3. THE SCHEMATIC SHOWS SYMBOLICALLY ONE PASS TRANSISTOR IN SERIES WITH ONE CURRENT SHARING RESISTOR. ACTUALLY, THERE ARE 4 (FOUR) SUCH TRANSISTOR/RESISTOR COMBINATIONS IN PARALLEL.
 4. RESISTOR VALUES IN OHMS, K=10³, M=10⁶.
 5. CAPACITOR VALUES IN MICROFARADS, UNLESS OTHERWISE NOTED.
 6. VOLTAGE READINGS ARE NOMINAL VALUES, TAKEN AT 115V AC INPUT, MAXIMUM DC OUTPUT VOLTAGE, NO LOAD AND REFERENCED TO THE COMMON (0VDC).
 7. THE RELAY K1 CONTACTS ARE SHOWN WHEN RELAY K14 IS DEENERGIZED. THE PREVIEW SWITCH (A452) IS IN "OFF" POSITION. (D.C. OUTPUT IS DISABLED)

8. JUMPER SHUNTS ARE INSTALLED ON J7 & J8 (SEE TABLE):

MODEL	E _O		J7		J8	
	VOLTS	VOLTS	1	2	1	2
MSK 20-5M	-20.0	+13.9			IN	IN
MSK 40-2.5M	-40.0	+19.7			IN	IN
MSK 60-2M	-60.0	+30			IN	IN
MSK 125-1M	-125.0	+59.2	IN			

9. EACH COMPONENT LABEL DESIGNATION STARTS WITH THE ASSEMBLY NUMBER FOLLOWED BY ITS OWN SCHEMATIC NUMBER WITHIN THE ASSEMBLY (EX. A2T1). FOR EASE OF SCHEMATIC MARKINGS THE PREFIX SHOWING THE ASSEMBLY NUMBER WAS LEFT OUT FOR COMPONENTS WITHIN ASSEMBLIES A1 & A3.

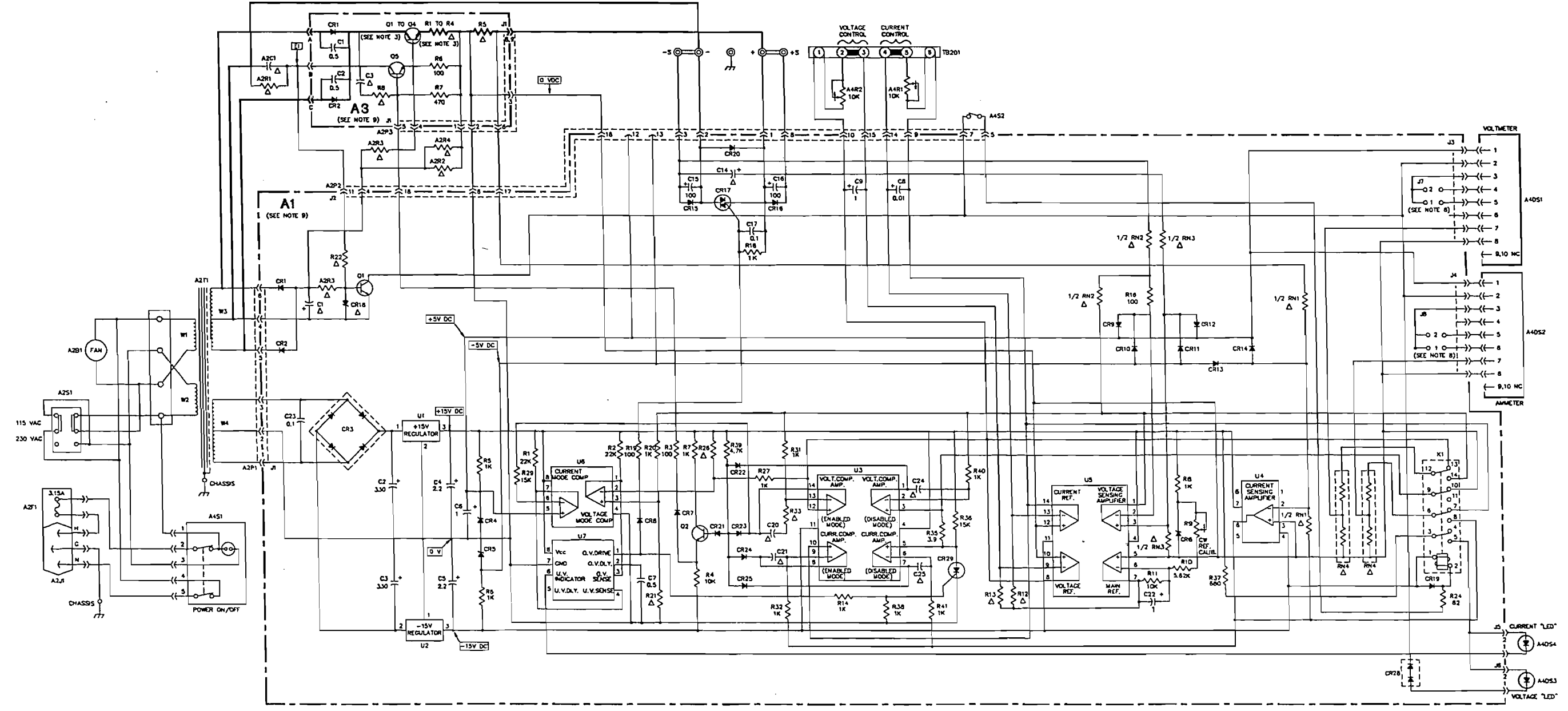

FIGURE 5-3 MAIN SCHEMATIC DIAGRAM



INSTRUCTION MANUAL CORRECTION

Please note the following corrections to the Manual Material as indicated:

Parts List:

1. ADD:	TB201	1	Barrier Strip	Kepeco #167-0882
	N/A	2	Link	Kepeco #172-0306

TEXT:

ADD: 2-16 LOCAL/REMOTE PROGRAMMING

For local front panel control of output voltage or current, terminals 2 & 3 and 4 & 5 on rear barrier strip TB201 are connected with links. (Standard factory setting).

For remote control of the output voltage, the link between 2 & 3 is removed disabling the front panel voltage control. An external variable resistor of 10K ohm is connected by the user between terminals 1 & 3. The zero to 10K ohm variable resistance will remotely program the output voltage from zero to full scale.

For remote control of the output current by an external resistor, the link between 4 & 5 should be removed disabling the front panel current control. An external variable resistor of 10K ohm is connected by the user between terminals 4 & 6. The zero to 10K ohm variable resistance will remotely program the output current from zero to full scale.

To minimize the noise pick-up, use twisted shielded cables between the power supply programming terminals and the remote resistors.

2. CHANGE:	F1	Fuse, Fast Blow, 5x20mm	3.0A/250V	Kepeco #141-0085
To:	F1	Fuse, Slow Blow, 5x20mm	3.15A/250V	Kepeco #141-0104

TEXT: 2-3 Paragraph has been replaced as follows:

The rear of the unit contains an input voltage selector switch. Set this switch to 115V or 230V position **before** connecting the unit to a power outlet: **Note: Also Install the fuse as follows:**

For 115V a-c operation: Fuse slow blow, 3.15A-250V a-c, 5mm x 20mm; Kepeco P/N 141-0104 or Schurter 034.3122.

For 230V a-c operation: Fuse slow blow, 1.6A-250V a-c, 5mm x 20mm; Kepeco P/N 141-0108 or Schurter 034.3119.

3. CHANGE:	B1	Motor, Fan	115V, 50-60Hz	Kepeco #148-0026
To:	B1	Motor, Fan	115V, 50-60Hz	Kepeco #148-0050

4. CHANGE:	Blade, Fan, Nylon	4" Dia., 4 Blades	Kepeco #149-0029
To:	Blade, Fan, Nylon	4" Dia., 5 Blades	Kepeco #149-0035

5. CHANGE:	C2, C3	Cap., Elec., Radial lds.	330UF, 20%, 35V	Kepeco #117-0879
To:	C2, C3	Cap., Elec., Radial lds.	330UF, 20%, 35V	Kepeco #117-1012

6. CHANGE:	C15, C16	Cap., Elec., Radial lds.	100UF, +44, -20%, 35V	Kepeco #117-1005
To:	C15, C16	Cap., Elec., Radial lds.	100UF, +44, -20%, 25V	Kepeco #117-1074

7. CHANGE:	C7	Cap.,	0.5UF, 10%, 200V	Kepeco #117-0123
To:	C7	Cap., Elec, Axial lds	47UF, 20%, 63V	Kepeco #117-1061

MSK 40-2.5M/10-1491/r6	C6356	MSK 40-2.5M/03-2204/r9	C9271
MSK 40-2.5M/02-2197/r7	C7665	MSK 40-2.5M/03-2204/r9	BMC
MSK 40-2.5M/10-0897/r7	C8077	MSK 40-2.5M/03-2204/r10	C10243
MSK 40-2.5M/09-2199/r7	BMC		

You must register your product to comply with the terms of the warranty. Either fill out the form below and mail or fax to Kepco, or for rapid on-line registration go to:

<http://www.kepcopower.com/warranty.htm>

PRODUCT PURCHASED:

Model Number) _____
Serial Number _____

PURCHASE INFORMATION:

Date Purchased: _____
Date Received: _____

REQUEST ADDITIONAL INFORMATION

- Send complete Catalog
- Have Sales Engineer Call
- Contact via: E-Mail Telephone Fax S-mail

REGISTER TO:

Registered by: _____
Company Name: _____
Street: _____
City: _____
State: _____
Country: _____
Zip: _____
E-mail: _____
FAX: _____
Phone: _____

WHAT INFLUENCED YOUR CHOICE OF THIS POWER SUPPLY?

- Previous Experience (which Kepco Models do you have?)

- Magazines (which ones?) _____

- Trade Shows (which ones?) _____
- Directory? _____

- Kepco Catalog or Brochure? _____
- Sales Representative?
- Web Site
- Other (please explain): _____

What products would you like to see Kepco make?

CUT HERE

Kepco 5 Year Warranty

This is to certify that we, KEPCO, INC., (hereinafter called "Company"), Flushing, NY 11355 USA, warrants for a period of FIVE YEARS, this instrument known as:

MODEL: _____

SERIAL NO. _____

The Company's products are warranted for a period of five years from date of delivery to be free from defects in materials and workmanship and to conform to the specifications furnished or approved by the Company. Liability under this warranty shall be limited to the repair or replacement of any defective product at Company's option.

If any defect within this warranty appears within the warranty period, the Purchaser shall promptly notify the Company in writing. No material will be accepted for repair or replacement without written authorization of the Company.

Upon such authorization, and in accordance with instructions of the Company, parts or materials for which replacement is requested shall be returned to the Company for examination, with shipping charges prepaid by the Purchaser. Final determination as to whether a product is actually defective rests with the Company.

This warranty does not extend to any product which has been subjected to misuse, neglect, accident, improper installation, or use in violation of instructions furnished by the Company. The warranty does not extend to, or apply to, any unit which has been repaired or altered outside of the Company's factory by persons not expressly approved by the Company.

THE WARRANTY HEREIN CONTAINED IS IN LIEU OF AND EXCLUDES ALL OTHER WARRANTIES, EXPRESS, IMPLIED OR STATUTORY, INCLUDING WITHOUT LIMITATION THE WARRANTY OF MERCHANTABILITY.

THIS KEPCO PRODUCT IS WARRANTED FOR FIVE YEARS!

KEPCO, INC. • 131-38 SANFORD AVENUE, FLUSHING,
NY 11352 USA • Tel. 718-461-7000 • Fax. 718-767-1102
E-mail: hq@kepcopower.com • URL: <http://www.kepcopower.com>



FOLD HERE

Please
place
stamp
here

KEPCO, INC.

131-38 SANFORD AVE.
FLUSHING, NY 11355 USA

CUT HERE