

# OPERATOR'S MANUAL

## JQE FULL RACK

## POWER SUPPLY

INCLUDES MODEL SUFFIX 8 AŽE, HS, M, T, VP

KEPCO INC.  
An ISO 9001 Company.

MODEL	CE
1000W	
JQE 6-90, JQE 15-50, JQE 25-40, JQE 36-30, JQE 55-20, JQE 75-15, JQE 100-10, JQE 150-7	

### IMPORTANT NOTES:

- 1) This manual is valid for the following Model and associated serial numbers:

MODEL	SERIAL NO.	REV. NO.
-------	------------	----------

- 2) A Change Page may be included at the end of the manual. All applicable changes and revision number changes are documented with reference to the equipment serial numbers. Before using this Instruction Manual, check your equipment serial number to identify your model. If in doubt, contact your nearest Kepco Representative, or the Kepco Documentation Office in New York, (718) 461-7000, requesting the correct revision for your particular model and serial number.
- 3) The contents of this manual are protected by copyright. Reproduction of any part can be made only with the specific written permission of Kepco, Inc.

Data subject to change without notice.

©2019, KEPKO, INC.  
P/N 228-1732-R2



KEPCO, INC. • 131-38 SANFORD AVENUE • FLUSHING, NY. 11355 U.S.A. • TEL (718) 461-7000 • FAX (718) 767-1102  
email: [hq@kepcopower.com](mailto:hq@kepcopower.com) • World Wide Web: <http://www.kepcopower.com>



### 1. Digital Meters

JQE models with the suffix DM indicates that the unit has digital meters in place of the analog meters. (NOTE: analog meters are no longer available.) Voltage meter accuracy is 1%; current meter accuracy is 1.5%. Meter range selector switches are no longer needed with the digital meters and have been removed on DM models. Refer to Figures 2, 3 and 4 for front panel views of the quarter rack, half rack, and full rack DM models.

### 2, PAR. 1-9

ADD: b) Side Support "L" Bracket P/N 128-1775 mounts to vertical rails to provide additional side support for rack-mounted models. 19.6 in. long x 2.3 in. high x 3.5 in. wide. Two (2) required per unit.

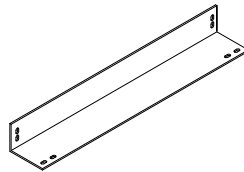

**FIGURE 1. SIDE SUPPORT "L" BRACKET P/N 128-1775**

### 3. SECTION III Correction

The instructions throughout Section III are based on a value of the front panel VOLTAGE control (R102) that requires an  $I_b$  of 1mA and a corresponding CONTROL RATIO ( $K_c$ ), also referred to as Programming Ratio, of 1000 Ohms/Volt.

To allow for the fact that the value of R102 may now be different, use the following procedure to determine the actual  $I_b$  and the corresponding CONTROL RATIO ( $1/I_b$ )

1. Turn the unit off and disconnect unit from source power.
2. Remove the link between positions 5 and 6 of TB501 (for JQE quarter rack models: remove link between positions 6 and 7 of TB1).
3. Set the Voltage potentiometer on the front panel to full clockwise.
4. Use a precision digital ohmmeter to measure the resistance between positions 4 and 5 of TB 501 (for JQE quarter rack models: measure resistance between positions 7 and 8 of TB1). This is the actual resistance of the front panel VOLTAGE control (R102), referred to as  $R_{VC \text{ Internal}}$ .
5. Use the measured value of R102 to calculate  $I_b$  as follows:  

$$I_b = (E_O + (\Delta E_O)) / R_{VC \text{ Internal}}$$
 where:  
 $E_O$  is the nominal output voltage (Volts).  
 $R_{VC \text{ Internal}}$  is the value of R102 measured in step 4 (Kilohms).  
 $I_b$  is the actual control current.  
 $\Delta E_O$  functions as voltage headroom to allow full scale from the front panel control.

6. Calculate the CONTROL RATIO as  $1/I_b$  (Kilohms/Volt) using the value of  $I_b$  calculated in step 5.
7. Use the calculated values of  $I_b$  and CONTROL RATIO for all procedures of Section III.

As an example, referring to the Procedure: Precision Programming Ratio Adjustment, PAR. 16, step c), instead of  $R_{VC} = 5K$  Ohms, use  $R_{VC} = 5$  ( $1/I_b$ ) (in Kilohms) in order to obtain an output voltage of 5V.

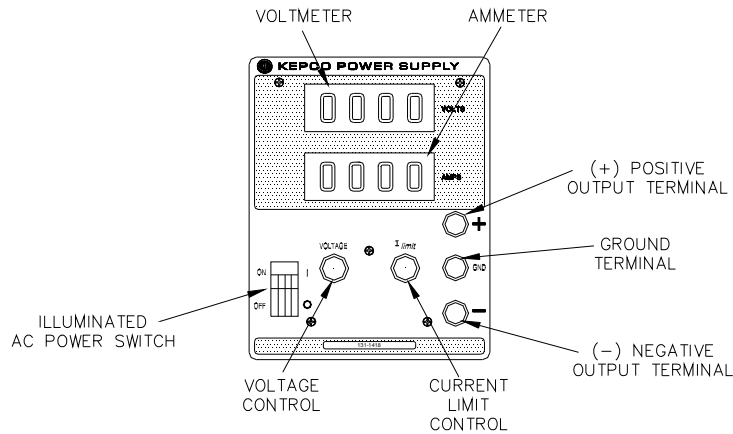

3043116

**FIGURE 2. FRONT PANEL VIEW OF JQE QUARTER RACK DM (DIGITAL METER) MODELS**

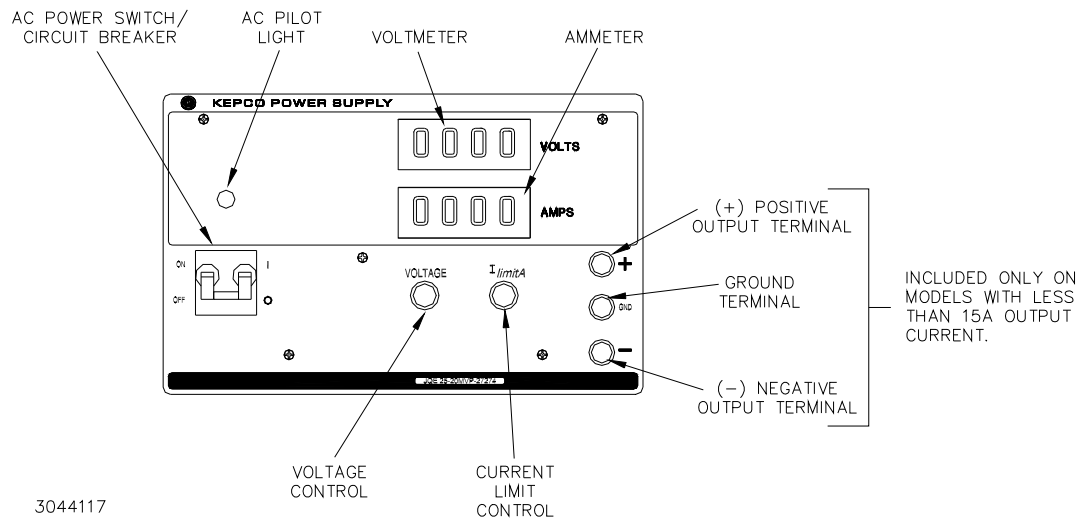

3044117

**FIGURE 3. FRONT PANEL VIEW OF JQE HALF RACK DM (DIGITAL METER) MODELS**

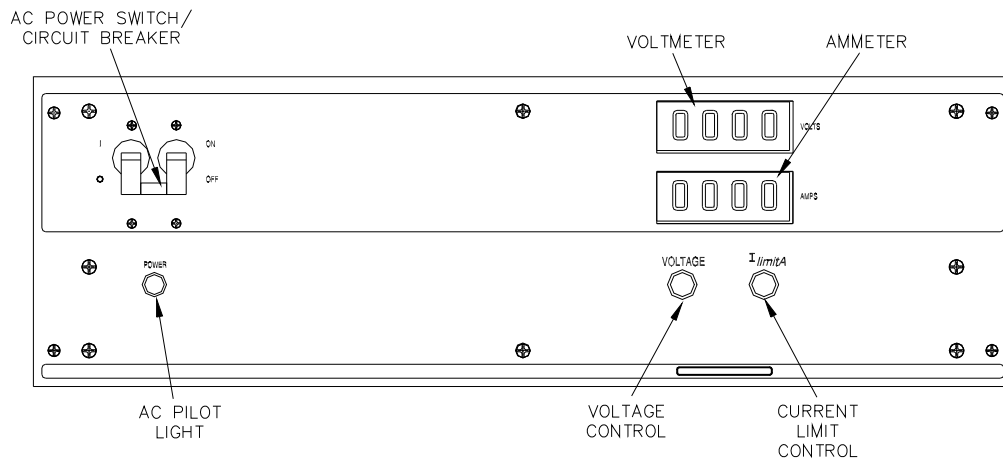

3044115

**FIGURE 4. FRONT PANEL VIEW OF JQE FULL RACK DM (DIGITAL METER) MODELS**



## Conditions of Conformance

When this product is used in applications governed by the requirements of the EEC, the following restrictions and conditions apply:

1. For European applications, requiring compliance to the Low Voltage Directive, 2006/95/EC, this power supply is considered a component product, designed for "built in" applications. Because it is incomplete in construction, the end product enclosure must provide for compliance to any remaining electrical safety requirements and act as a fire enclosure. (EN61010-1:2010, Cl. 6, Cl. 7, Cl.8, and Cl. 9)
2. This power supply is designed for stationary installation, with mains power applied via a detachable power supply cord or via direct wiring to the source power terminal block.
3. This power supply is considered a Class 1 (earthed) product, and as such depends upon proper connection to protective earth for safety from electric shock. (EN61010-1 Cl. 6.5.5)
4. This power supply is intended for use as part of equipment meant for test, measurement and laboratory use, and is designed to operate from single phase, three wire power systems. This equipment must be installed within a suitably wired equipment rack, utilizing a three wire (grounded) mains connection. See wiring section of this manual for complete electrical wiring instructions. (EN61010-1 Cl. 6.5.5 and Cl.6.10.1)
5. For European applications requiring compliance with the RoHS 2 directive, 2011/65/EU, this power supply is designed for scientific research and technological development, and is excluded from the scope of the directive [2011, 65/EU, Article 2 (4) (j)].
6. This power supply has secondary output circuits that are considered hazardous, and which exceed 240 VA at a potential of 2V or more.
7. The output wiring terminals of this power supply has not been evaluated for field wiring and, therefore, must be properly configured by the end product manufacturer prior to use.
8. This power supply employs a supplementary circuit protector in the form of a circuit breaker mounted on the front panel. This circuit breaker protects the power supply itself from damage in the event of a fault condition. For complete circuit protection of the end product, as well as the building wiring, it is required that a primary circuit protection device be fitted to the branch circuit wiring. (EN61010-1:2010, Cl. 9.6)
9. Hazardous voltages are present within this power supply during normal operation. All operator adjustments to the product are made via externally accessible switches, controls and signal lines as specified within the product operating instructions. There are no user or operator serviceable parts within the product enclosure. Refer all servicing to qualified and trained Kepco service technicians.

# SAFETY INSTRUCTIONS

## 1. Installation, Operation and Service Precautions

This product is designed for use in accordance with EN 61010-1 and UL 3101 for Installation Category 2, Pollution Degree 2. Hazardous voltages are present within this product during normal operation. The product should never be operated with the cover removed unless equivalent protection of the operator from accidental contact with hazardous internal voltages is provided:



There are no operator serviceable parts or adjustments within the product enclosure. Refer all servicing to trained service technician.



Source power must be removed from the product prior to performing any servicing.



This product is factory-wired for the nominal a-c mains voltage indicated on the rating nameplate located adjacent to the source power connection on the product's rear panel. To reconfigure the product input for other nominal mains voltages as listed herein, the product must be modified by a trained service technician.

## 2. Grounding

This product is a Class 1 device which utilizes protective earthing to ensure operator safety.



The PROTECTIVE EARTHING CONDUCTOR TERMINAL must be properly connected prior to application of source power to the product (see instructions on installation herein) in order to ensure safety from electric shock.



PROTECTIVE EARTHING CONDUCTOR TERMINAL - This symbol indicates the point on the product to which the protective earthing conductor must be attached.



EARTH (GROUND) TERMINAL - This symbol is used to indicate a point which is connected to the PROTECTIVE EARTHING TERMINAL. The component installer/ assembler must ensure that this point is connected to the PROTECTIVE EARTH-ING TERMINAL.

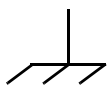

CHASSIS TERMINAL - This symbol indicates frame (chassis) connection, which is supplied as a point of convenience for performance purposes (see instructions on grounding herein). This is not to be confused with the protective earthing point, and may not be used in place of it.

## 3. Electric Shock Hazards

This product outputs hazardous voltage and energy levels as a function of normal operation. Operators must be trained in its use and exercise caution as well as common sense during use to prevent accidental shock.



This symbol appears adjacent to any external terminals at which hazardous voltage levels as high as 500V d-c may exist in the course of normal or single fault conditions.



This symbol appears adjacent to any external terminals at which hazardous voltage levels in excess of 500V d-c may exist in the course of normal or single fault conditions.



# TABLE OF CONTENTS

PARAGRAPH		PAGE
<b>SECTION I – INTRODUCTION</b>		
1-1	Scope of Manual . . . . .	1-1
1-3	General Description . . . . .	1-1
1-9	Accessories . . . . .	1-1
1-10	Specifications, General . . . . .	1-1
1-11	Specifications, Electrical . . . . .	1-2
1-12	Specifications, Performance . . . . .	1-3
1-13	Specifications, Physical . . . . .	1-3
<b>SECTION II – INSTALLATION</b>		
2-1	Unpacking and Inspection . . . . .	2-1
2-3	Terminations . . . . .	2-1
2-4	AC Input Requirements . . . . .	2-2
2-6	Cooling . . . . .	2-2
2-8	Preliminary Check-Out . . . . .	2-2
2-10	Installation . . . . .	2-3
2-12	Grounding . . . . .	2-3
<b>SECTION III – OPERATION</b>		
3-1	Standard Power Supply Operation, Local Control . . . . .	3-1
3-4	Remote Error Sensing . . . . .	3-1
3-6	Output Adjustment . . . . .	3-2
3-8	Introduction to Remote Programming . . . . .	3-2
3-10	Equations Showing the Operation of the Kepco Bridge . . . . .	3-2
3-12	Adjustments for Exact Programming Ratio . . . . .	3-3
3-17	General Rules for Remote Programming . . . . .	3-5
3-19	Output Voltage Programming with External Resistance . . . . .	3-5
3-21	Programming by Conductance . . . . .	3-6
3-24A	Internal Adjustment Procedures . . . . .	3-7
3-25	Remote Programming with External Voltage . . . . .	3-8
3-29	Constant Current Operation . . . . .	3-9
3-34	Series Operation of two or more JQE Supplies . . . . .	3-11
3-40A	Parallel Operation of two or more JQE Supplies . . . . .	3-14

## LIST OF ILLUSTRATIONS

FIGURE		PAGE
1-1	Kepeco Full-Rack JQE Power Supply, Front View (Typical) . . . . .	-iii-
1-2	Kopco Full-Rack JQE Power Supply, Rear View (Typical) . . . . .	-iv-
1-3	Mechanical Outline Drawing . . . . .	1-4
2-1	Location of Internal Adjustments . . . . .	2-1
2-2	Conversion to 230V AC Operation . . . . .	2-2
2-3	Controls and Terminations, JQE Full-Rack Models, Front . . . . .	2-4
2-4	Rear Terminations, JQE Full-Rack Models . . . . .	2-5
2-5	Rack Installation . . . . .	2-6
3-1	Load Connection without Error Sensing . . . . .	3-1
3-2	Load Connection with Error Sensing . . . . .	3-1
3-3	Kepeco Power Supply Circuit with Comparison Bridge . . . . .	3-2
3-4	Connections for Precision Programming Ratio Adjustment . . . . .	3-4
3-5	Establishing Programming Linearity . . . . .	3-4
3-6	Remote Resistance Programming . . . . .	3-6
3-7	Remote Conductance Programming . . . . .	3-7
3-8	The Power Supply in the Operational Amplifier Mode . . . . .	3-8
3-9	Constant Current Operating Mode . . . . .	3-10
3-10	Automatic Series Connection . . . . .	3-12
3-11	Master-Slave Series Connection . . . . .	3-13
3-12	Parallel Operation . . . . .	3-14
3-13	Basic Parallel Connection . . . . .	3-15
3-14	Master-Slave Parallel Connection . . . . .	3-16

## LIST OF TABLES

TABLE		PAGE
1-1	JQE (Full-Rack) Group, Specifications-General . . . . .	1-2
1-2	JQE (Full-Rack) Group, Specifications-Electrical . . . . .	1-3
2-1	Internal Adjustments . . . . .	2-1
2-2	Controls and Terminations, Full-Rack JQE Models, Front . . . . .	2-4
2-3	Rear Terminations, Full-Rack JQE Models . . . . .	2-5

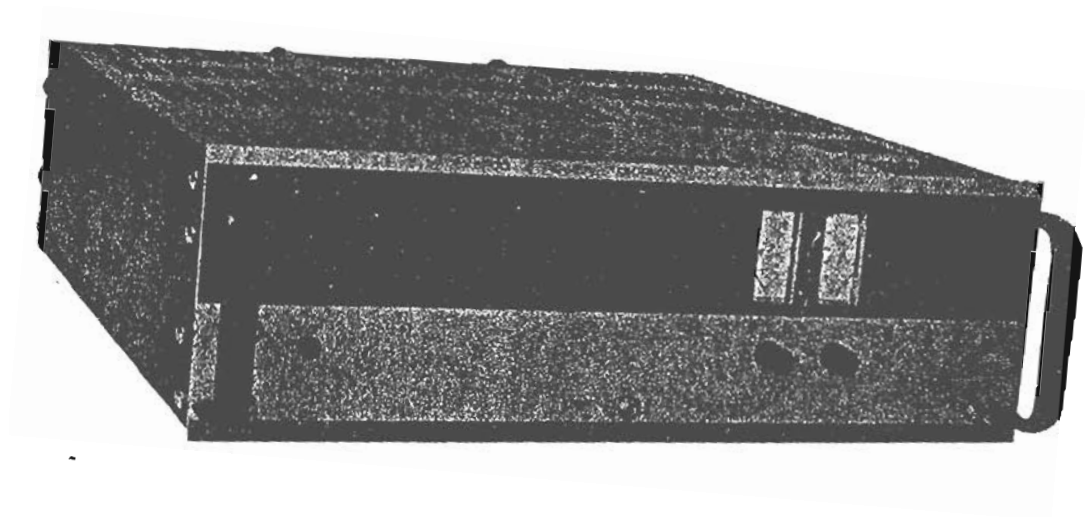

FIG. 1-1 KEPCO FULL-RACK JQE POWER  
SUPPLY, FRONT VIEW (TYPICAL)

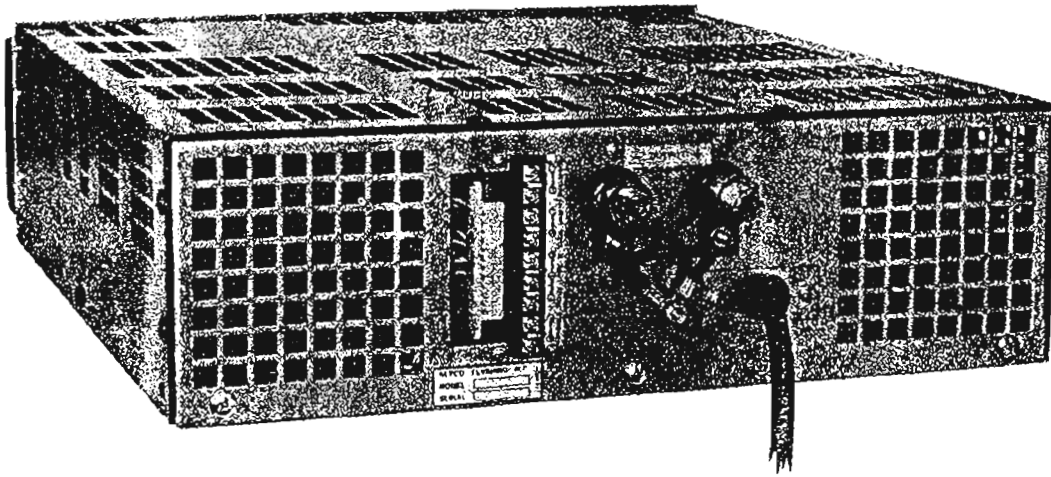

FIG. 1-2 KEPCO FULL-RACK JQE POWER  
SUPPLY, REAR VIEW (TYPICAL)

## SECTION I – INTRODUCTION

### 1-1 SCOPE OF MANUAL

- 1-2 This manual contains instructions for the installation and operation of the Kepco JQE "FULL-RACK" Series of Power Supplies.

### 1-3 GENERAL DESCRIPTION

- 1-4 Kepco L-Series JQE Power Supplies are general purpose, precision regulated voltage sources in the "FULL-RACK" configuration. JQE Power Supplies feature full range voltage control and current limit adjustment by means of multi-turn front panel controls. Dual range meters monitor output voltage and load current. JQE Power Supplies have linear, full-dissipation series-regulators (NPN) driven by an integrated circuit operational amplifier. A sharp current-limit circuit renders the power supply completely short-circuit proof. JQE Power Supplies may be readily converted to provide constant current by the addition of an external sensing resistor and a "current control". The output of the JQE Power Supply is completely programmable. All necessary connections are available on terminals at the rear barrier-strip.
- 1-5 The compact design of the Kepco JQE "FULL-RACK" Series was made possible by a unique heatsink design of exceptional efficiency in combination with highly reliable low-noise fans. JQE Power Supplies feature all-silicon design with conservatively rated components for added reliability.
- 1-6 JQE Power Supplies are identical in their mechanical dimensions (Refer to FIG. 1-3, "Mechanical Outline Drawing") and in their electrical specifications, except as noted in TABLE 1-1.
- 1-7 **OPTIONS.** Optional features of Kepco Power Supplies are indicated by a letter following the model designation:
- JQE Power Supplies with suffix "E" are equipped with an "E<sub>0</sub> Null" adjustment, which allows exact zero calibration for precision programming applications.
  - JQE Power Supplies with suffix "HS" are optimized for high speed programming. For these models, a special addendum containing all supplementary specifications is provided in the appendix of the manual. The "E<sub>0</sub> Null" ("E") option is automatically included with the "HS" option.
  - JQE Power Supplies with suffix "M" are equipped with two dual range panel meters which permit simultaneous monitoring of the output voltage and output current. Meter range-switches allow for full scale reading of either 10% or 100% of the voltage and current outputs.
  - JQE Power Supplies with suffix "T" have special references which improve the temperature coefficient of the supply (See paragraph 1-11 for specifications).
  - JQE Power Supplies with suffix "VP" are equipped with an overvoltage protector. This electrical "crowbar" shorts the output through a silicon controlled rectifier (SCR) if the output voltage exceeds a preadjustable limit on the protector (See paragraph 1-12 for specifications).
  - JQE Power Supplies with suffix "L" are equipped with locking-type screw-driver-adjustable controls in place of the front panel control knobs. Ignore references in this manual to front panel controls for these models.
- 1-8 The main chassis frame of the power supply is constructed from cold-rolled steel, as is the perforated wrap-around cover. Front panel material is aluminum (Refer to FIG. 1-3 for finish).

### 1-9 ACCESSORIES

- a) Mounting Brackets for rack-installation (supplied, see FIG. 2-5 for installation instruction).

### 1-10 SPECIFICATIONS, GENERAL

- AC INPUT: 105 to 125V AC or 210 to 250V AC (selectable, refer to SECTION II), 50 to 65 Hz,\* single phase. Refer to the table of general specifications (TABLE 1-1) for the AC input current for each model.
- OPERATING TEMPERATURE RANGE: (-)20°C to (+)71°C (without derating of the output).
- STORAGE TEMPERATURE: -50°C to (+)85°C.
- COOLING: High efficiency, single bearing fans, (permanently lubricated) with special low noise non-metal blade.
- ISOLATION: A maximum of 500 volts (DC or p-p) can be connected between chassis and either output terminal.

\*Consult factory for operation above 65 Hz.

## 1-11 SPECIFICATIONS, ELECTRICAL

a) Refer to TABLE 1-1 and 1-2

MODEL	DC OUTPUT RANGE		OUTPUT IMPEDANCE (OHMS + $\mu$ H)			APPROXIMATE MAXIMUM AC INPUT CURRENT Amps @ 125V AC
	VOLTS	AMPERES	DC-100 Hz	0.1-1 kHz	1 kHz-100 kHz	
JOE 6-90(M)	0-6	0-90	$3.5 \times 10^{-6}$	0.001	0.005 + 1	15.7
JOE 15-50(M)	0-15	0-50	$15.0 \times 10^{-6}$	0.001	0.005 + 1	16.6
JOE 25-40(M)	0-25	0-40	$31.0 \times 10^{-6}$	0.001	0.005 + 0.5	21.0
JOE 35-30(M)	0-35	0-30	$70.0 \times 10^{-6}$	0.001	0.005 + 0.5	19.0
JOE 55-20(M)	0-55	0-20	$1.38 \times 10^{-4}$	0.01	0.02 + 1	18.0
JOE 75-15(M)	0-75	0-15	$2.50 \times 10^{-4}$	0.005	0.01 + 1	18.0
JOE 100-10(M)	0-100	0-10	$6.2 \times 10^{-4}$	0.005	0.02 + 1	17.0
JOE 150-7(M)	0-150	0-7	$1.1 \times 10^{-3}$	0.01	0.05 + 2	18.0

NOTE: Specifications for unmetred models (without suffix "M") are identical.

TABLE 1-1 DC OUTPUT AND AC INPUT SPECIFICATIONS.

NOTE: Kepco has adopted new technical terms recommended by the International Electrotechnical Commission (IEC). These terms replace or supplement previously used expressions to avoid difficulties in translation and prevent erroneous interpretations at home and abroad.

In this instruction manual, Kepco discontinued the use of the specifications entitled "line regulation" and "load regulation." Instead, Kepco will follow the recommendation of the IEC and speak of the "Output Effects, caused by changes in the influence Quantities." The "Output Effects" are specified either as a percentage change referred to the maximum specified output voltage ( $E_o$ ) or current ( $I_o$ ) or as an absolute change ( $\Delta E_o$ ,  $\Delta I_o$ ) directly in millivolts or milliamperes or both. The "Influence Quantities" are the "Source Variations" (formerly a-c line variations), the "Load Variations" (formerly load regulation), the "Temperature Variations" (no change, still specified as a coefficient) and the "Time Variations" (formerly stability). The illustration below will clarify the use of the new terminology.

### INFLUENCE QUANTITIES

- 1) SOURCE VARIATIONS
- 2) LOAD VARIATIONS
- 3) TEMPERATURE VARIATIONS
- 4) TIME VARIATIONS

### AC INPUT SOURCE (FORMERLY "AC LINE")

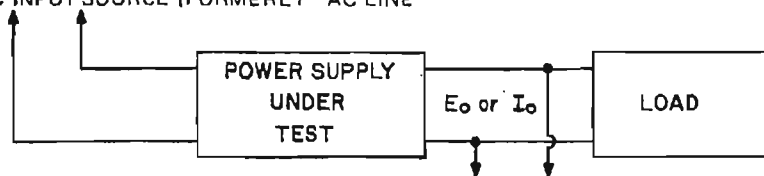

### OUTPUT EFFECTS ( $\Delta E_o$ , $\Delta I_o$ )

- |                             |  |
|-----------------------------|--|
| 1) DUE TO SOURCE VARIATIONS | = SOURCE EFFECT . . . . . (formerly LINE REGULATION) |
| 2) DUE TO LOAD VARIATIONS   | = LOAD EFFECT . . . . . (formerly LOAD REGULATION)   |
| 3) DUE TO TEMPERATURE       | = TEMPERATURE COEFFICIENT. (COEFFICIENT, NO CHANGE)  |
| 4) DUE TO TIME              | = DRIFT . . . . . (formerly STABILITY)               |

- b) VOLTAGE RECOVERY TIME: (for step load current),  $< 50 \mu$ sec.
- c) OVERTSHOOT: No output voltage overshoot from turn-on, turn-off, or power failure for output settings above 25% of maximum rated output voltage. Below 25% output voltage overshoot is a function of load current and is negligible for loads in excess of 10% of the maximum rated load current.

SPECIFICATION	OUTPUT EFFECTS VOLTAGE MODE	OUTPUT EFFECTS CURRENT MODE <sup>(2)</sup>	VOLTAGE AMPLIFIER OFFSETS <sup>(3)</sup>		VOLTAGE REFERENCE (Internal) <sup>(3)</sup>
			OFFSET VOLTAGE $\Delta E_{IO}$	OFFSET CURRENT $\Delta I_{IO}$	
OUTPUT RANGE:	0-100% $E_{O \max}$	1 mA-100% $I_{O \max}$	—	—	Fixed 6.2V $\pm 5\%$
SOURCE: 105-125/210-250V a-c	<0.0005%	<0.005%	< 10 $\mu$ V	<2nA	0.0001%
LOAD: No load—full load	<0.005% or 0.2 mV <sup>(1)</sup>	<0.01%	<200 $\mu$ V	<5nA	—
TIME: 8-hours (drift)	<0.01% or 1 mV <sup>(1)</sup>	<0.02%	< 20 $\mu$ V	<2nA	0.005%
TEMPERATURE: Per °C	<0.01%	<0.02%	< 20 $\mu$ V	<5nA	0.005%
RIPPLE and NOISE (rms) (p-p) <sup>(4)</sup>	<0.2 mV <1.0 mV	<0.02% of $I_{O \max}$ <0.1% of $I_{O \max}$ .	—	—	—

**NOTES:**

- (1) Whichever is greater.
- (2) Current Mode Output Effects ( $\Delta I_{IO}$ ) are measured across the external sensing resistor. This resistor must be a high quality, wirewound unit, with a wattage at least 10 times the actual power dissipated, have a Temperature Coefficient of 20 parts per million or better and drop a sample voltage of 1.0 volt at the measuring current. A resistor built as a 4-terminal network is recommended. Current control is exercised with an external 20 PPM feedback resistor.
- (3) Offsets and the reference contribute to output effect  $\Delta E_{IO}$  by the equation  $\Delta E_{IO} = \pm \Delta E_{ref} (R_f/R_i) \pm \Delta E_{IO} (1 + R_f/R_i) \pm \Delta I_{IO} (R_f)$  where  $R_f$  is the feedback resistor and  $R_i$  is the input resistor from the signal reference. Use the offsets to calculate output effects when external input/feedback elements are substituted for the internal reference and voltage control in special applications.
- (4) 20 Hz to 10 MHz.

TABLE 1-2 ELECTRICAL SPECIFICATIONS

**1-12 SPECIFICATIONS, PERFORMANCE**

- a) **VOLTAGE CONTROL\***: 10 turn precision rheostat at the front panel, resolution: 0.05% of  $E_{O \max}$ . controls the output voltage from zero to  $E_{O \max}$ .
- b) **CURRENT LIMIT CONTROL\***: 10 turn vernier control at the front panel permits adjustment of the current limit from 10% to 105% of the maximum rated output current ( $I_{O}$ ).
- c) **REMOTE ERROR SENSING**: Rear barrier-strip terminals provide for connection of the error sensing leads directly at the load, thus compensating for losses due to load current voltage drops. Up to 0.5V per output lead can be compensated.
- d) **REMOTE PROGRAMMING**: Rear barrier terminals provide for remote control of the power supply by resistance (control loop uses 1 mA with a Programming Ratio of 1000 ohms per volt), or by external control voltage.
- e) **SERIES/PARALLEL**: Series operation of JQE Power Supplies is possible up to the rated Isolation voltage. Parallel operation using "Automatic Parallel" or "Slave-Master" parallel connections may be performed.
- f) **OVERVOLTAGE PROTECTOR (MODELS WITH SUFFIX "VP")**  
Electronic "Crowbar" circuit shorts the output through a silicon controlled rectifier (SCR) as soon as the power supply output voltage reaches a present limit on the "VP" device. The over-voltage protector device (VP) has the following specifications:
  - 1) **RANGE**: 3V d-c - 175V d-c (adjustable).
  - 2) **TRIGGERING TIME**: 5 to 10 microseconds, adjustable by means of a delay-control.
  - 3) **THRESHOLD**: Overvoltage device may be set to within 5% or 0.25 volts of the power supply's output voltage (whichever is greater).

\*Knob controlled on all metered models (suffix "M"), locking type screw-driver controls on unmetered models.

**1-13 SPECIFICATIONS, PHYSICAL**

- a) **DIMENSIONS**: Refer to "Mechanical Outline Drawing", (FIG. 1-3).
- b) **TERMINATIONS**: Refer to "Mechanical Outline Drawing" (FIG. 1-3) and Section II of this manual.
- c) **FINISH**:
  - 1) **CHASSIS**: cadmium plated, cronak wash.
  - 2) **PANEL**: (on models with suffix "M" only): Light gray, Color #26440, Federal Standard 595.
  - 3) **CASE**: Charcoal gray texture.
- d) **METERS** (on models with suffix "M" only): Two dual range (100% and 10% of  $E_{O \max}$  and  $I_{O \max}$ ), 2 inch recessed panel meters, accuracy 3% of full scale reading, for output voltage and output current monitoring.
- e) **MOUNTING**: Refer to "Mechanical Outline Drawing" (FIG. 1-3). Four (4) aluminum feet are provided for bench operation of the supply. Feet are removable for rack-mounting. Adapter brackets for mounting the supply into a standard (19 inch) rack are supplied. Refer to FIG. 2-5 for installation instructions.

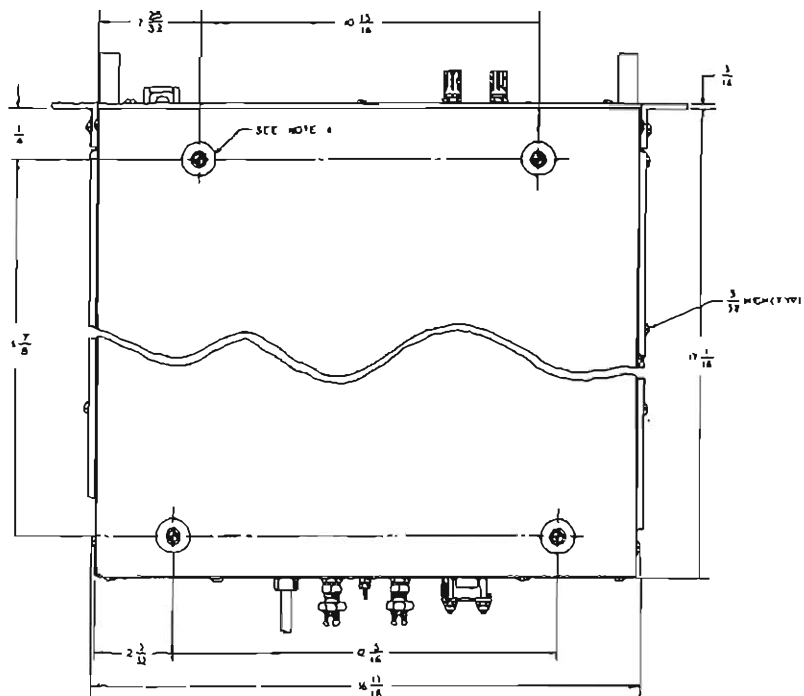
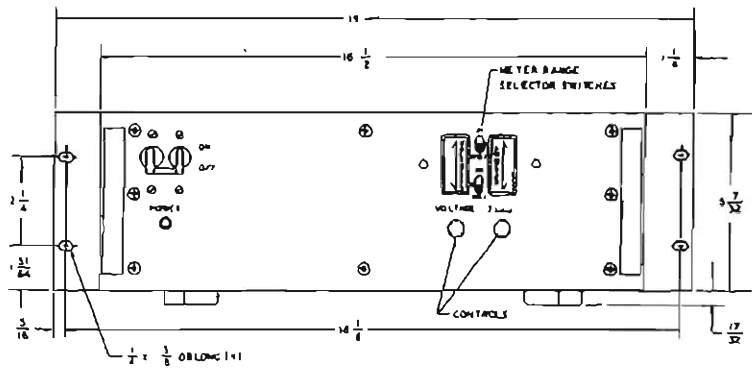
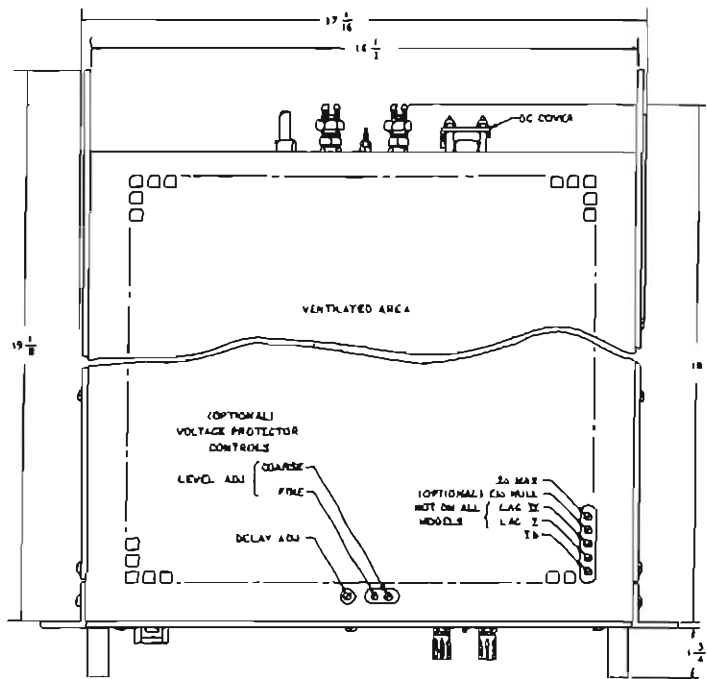

**REAR OUTPUT TERMINAL FUNCTIONS**

- 1 (+) OUTPUT MONITOR
- 2 (-) SENSING
- 3 (-) OUTPUT MONITOR
- 4 (-) SENSING
- 5 R<sub>1</sub>
- 6 NULL JUNCTION
- 7 R<sub>2</sub>
- 8 E<sub>1</sub>
- 9 R<sub>3</sub>

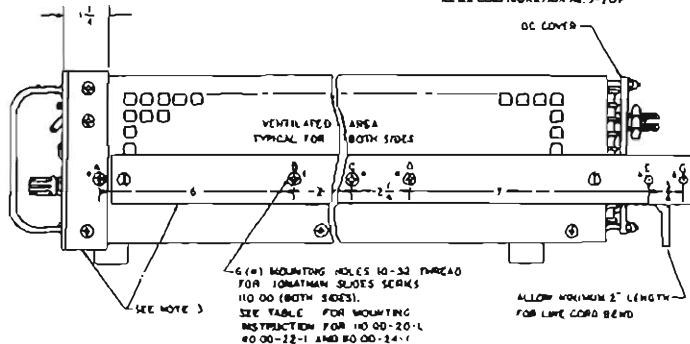
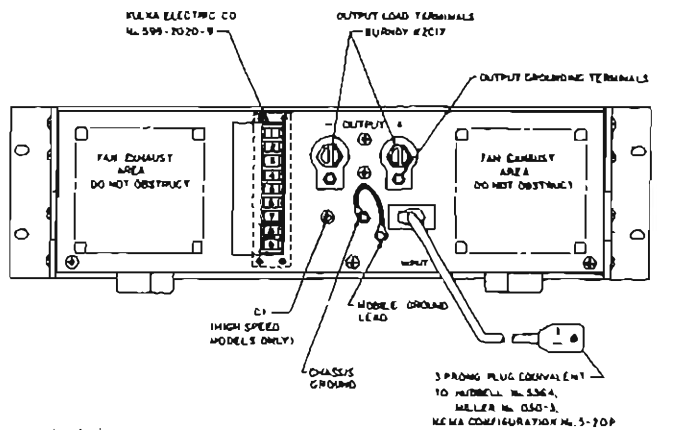

MOUNTING TABLE				
SLIDE TYPE	USE INSULATING HOLES			
11000-20-1	A	B	D	E
11000-22-1	A	C	D HOLE HAS TO BE ADDED TO SLIDE (BOTH SIDES) 3/8" DIA HOLE 1/8" FROM "K" HOLE	
8000-24-1	A	C	E	NOT USED

- NOTES: 1. THIS DRAWING IS USED FOR THE MODELS: JOE 25-40 (M)(V)(E)(T)(H)(S), JOE 16-30 (M)(V)(E)(T)(H)(S), JOE 25-35 (M)(V)(E)(T)(H)(S) AND JOE 26-35 (M)(V)(E)(T)(H)(S)
2. MATERIAL: A) CHASSIS: 1116A, C.P.S. B) FRONT PANEL: 3/16 THICK ALUMINUM C) COVER: 3/32 THICK ALUMINUM
3. FINISH: A) CHASSIS: CADMIUM PLATE WITH A YELLOW CHROMATE WASH B) FRONT PANEL: LIGHT GRAY PER FEDERAL STD. 596, COLOR # 26440 C) COVER: CHARCOAL GRAY VENT. TEXTURE.
4. FIXED ANGLE BRACKETS AND CHASSIS SLIDE SUPPORT BAR (BOTH ENDS) USED FOR BACK OR CABINET INSTALLATION CAN BE REMOVED FOR BENCH OPERATION
5. (#1) ALUMINUM FEET TO BE REMOVED FOR BACK OR CABINET MOUNTING

**CAUTION**  
WHEN INSTALLING MODEL INTO BACK OR CABINET, THE MODEL MUST BE SUPPORTED EITHER BY FIXED ANGLE BRACKETS (SEE NOTE #3) AND CHASSIS SLIDE (SEE MOUNTING TABLE) OR BY FIXED ANGLE BRACKETS AND RIGID PLATFORM MOUNTED IN THE BACK OR CABINET.  
NOTE: CHASSIS SLIDES AND RIGID PLATFORM ARE NOT SUPPLIED

FIG. 1-3 MECHANICAL OUTLINE DRAWING





## 2-4 AC INPUT REQUIREMENTS

- 2-5 This power supply is normally supplied for operation on a single phase, nominal 115V AC line. For conversion to 230V AC line operation, refer to FIG. 2-2. Remove the two links between transformer terminals (1)-(2) and (3)-(4). Reconnect one (1) link between terminals (2) and (3). DO NOT CHANGE ANY OTHER WIRING ON THE TRANSFORMER.

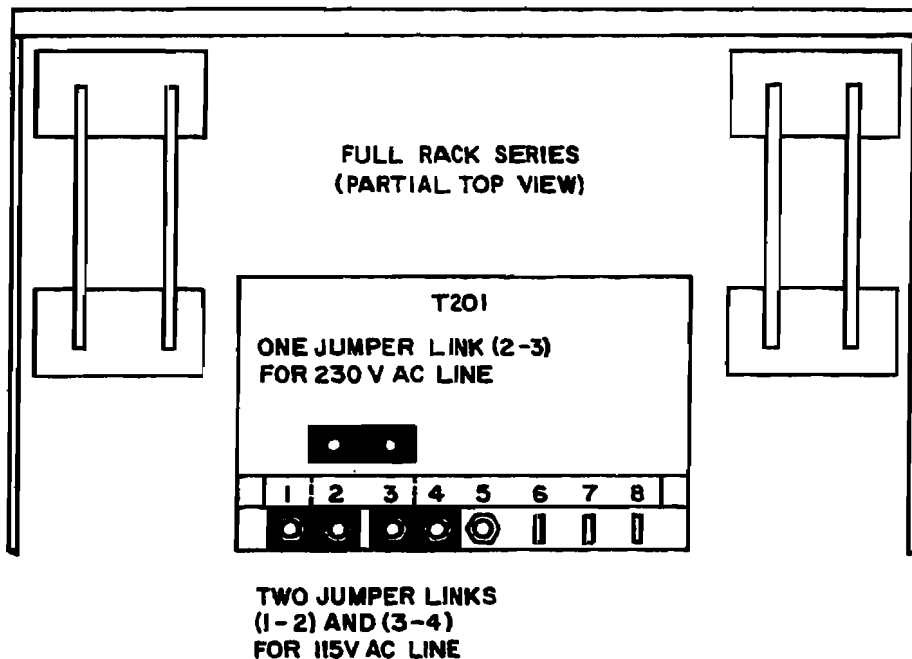

FIG. 2-2 CONVERSION TO 230V AC NOMINAL LINE OPERATION

## 2-6 COOLING

- 2-7 The power transistors and rectifiers in this power supply are maintained within their operating temperature range by means of high efficiency heat-sink assemblies, cooled by internal fans. SIDE PANEL OPENINGS AND THE TOP OF THE CASE MUST BE KEPT CLEAR FROM OBSTRUCTIONS TO INSURE PROPER AIR CIRCULATION. Periodic cleaning of the interior of the power supply is recommended. If the power supply is rack mounted, or installed into confined spaces, care must be taken that the ambient temperature does not rise above the limit specified (71°C).

## 2-8 PRELIMINARY CHECK-OUT

- 2-9 A simple operating check after unpacking and before permanent installation is advisable, to ascertain whether the power supply has suffered damage resulting from shipment. Please refer to FIG. 2-3 for the location of the operating controls and output terminals.
- Connect power supply to 115V AC line or refer to paragraph 2-4 for 230V AC operation if required.
  - If power supply is unmetred, connect a suitable DC voltmeter to the output terminals.
  - Turn CURRENT LIMIT CONTROL fully clockwise. Turn VOLTAGE CONTROL fully counterclockwise. Turn V-LIMIT fully clockwise.
  - Turn AC POWER SWITCH "on". The AC PILOT LIGHT (metered models only) should be energized. Slowly turn VOLTAGE CONTROL clockwise and observe the gradual increase of the output voltage. Turn counterclockwise again.

- e) (MODELS WITH SUFFIX "VP" ONLY). Adjust output voltage to approximately 1/4 of its maximum rated value. Turn V-LIMIT control slowly counterclockwise, until output voltage goes suddenly to zero and the AC POWER SWITCH/CIRCUIT BREAKER trips. Leave AC power "off".



CONNECT SHORT CIRCUIT (OR LOAD) TO THE HEAVY DUTY OUTPUT TERMINALS, NOT TO THE BARRIER-STRIP TERMINALS. BARRIER-STRIP TERMINALS ARE FOR VOLTAGE MONITORING AND PROGRAMMING CONNECTIONS ONLY.

- f) (MODELS WITH FRONT PANEL METERS ONLY)  
Place a short circuit across the output. Turn CURRENT LIMIT CONTROL counterclockwise. Turn AC POWER SWITCH/CIRCUIT BREAKER "on". Slowly turn CURRENT LIMIT CONTROL clockwise and observe the gradual increase in output current on the panel AMMETER. The output current should smoothly increase from below 10% to 105% of the maximum rated output current, as the CURRENT LIMIT CONTROL is varied between its limits. Turn AC power "off". This concludes the preliminary check-out.
- g) (MODELS WITHOUT METERS)  
Place a short circuit, consisting of a suitable ammeter, across the output terminals of the unit. Turn CURRENT LIMIT CONTROL fully counterclockwise. Turn AC POWER SWITCH/CIRCUIT BREAKER "on". Slowly turn CURRENT LIMIT CONTROL clockwise, observing the ammeter scale. The output current should smoothly vary from below 10% to 105% of maximum rated output current as the CURRENT LIMIT CONTROL is adjusted from its maximum counterclockwise position. Turn AC power "off". This concludes the preliminary check-out.

## 2-10 INSTALLATION

### 2-11 a) (METERED MODELS)

The JQE Power Supply may be used as a bench operated instrument or, with the assistance of the mounting brackets, it may be installed in any standard 19 inch rack. Please refer to paragraph 2-6 ("COOLING") if the supply is mounted into a multiple rack installation. Instructions for rack installation are provided (See FIG. 2-5).

### b) (UNMETERED MODELS)

The JQE Power Supply is designed for chassis mounting directly into existing installations. For mounting hole dimensions and lay-out see FIG. 1-3 ("Mechanical Outline Drawing"). If the unit must be mounted into confined spaces, refer to paragraph 2-6 ("COOLING").

## 2-12 GROUNDING

- a) AC GROUND. The power supply is equipped with a 3-wire safety line cord and polarized plug.\* The third (green) wire in the line cord is connected to the chassis and the case of the unit. If a two terminal AC power receptacle in combination with an adaptor is used, it is imperative that the chassis of the power supply be returned to AC ground with a separate lead.
- b) DC GROUND. The DC output is isolated from the AC power line and from any direct connection to chassis or ground.\*\* The maximum voltage that can be supported between either output terminal and ground or chassis is 500V (DC or p-p) plus the maximum output voltage of the power supply. For lowest output ripple and noise the grounding of one side of the output is recommended.

\*Metered models only (suffix "M"). Unmetered models have a three (3) terminal barrier-strip for AC input. Terminal "G" on the barrier-strip is connected to chassis and case.

\*\*A capacitor-resistor network (C5, R25) is connected from the negative (-) output terminal to chassis. If the output is to be grounded elsewhere, this internal ground can be opened by removing C5 from the amplifier board (A1, FIG. 6-2).

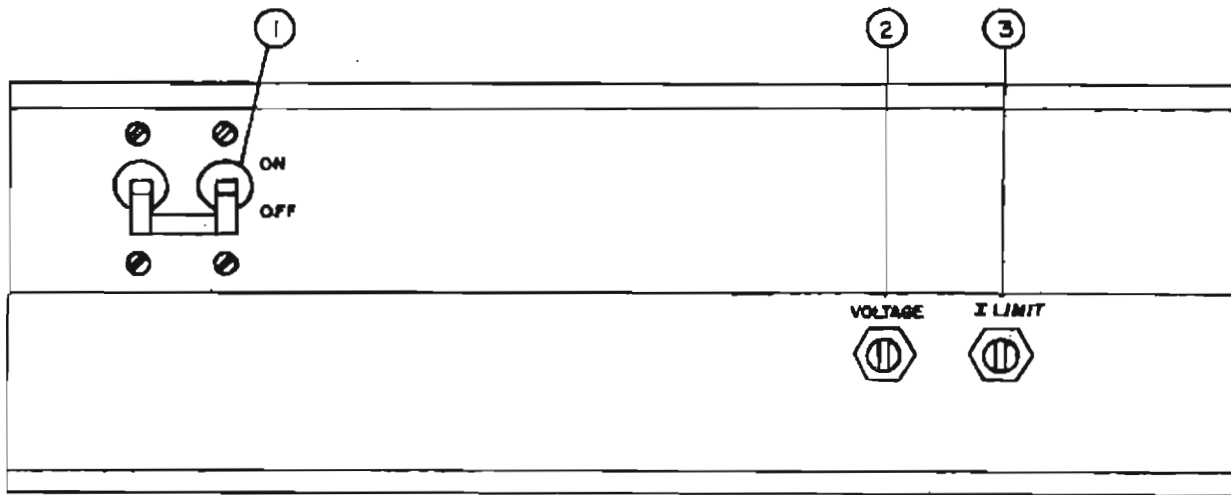

a) UNMETERED MODELS

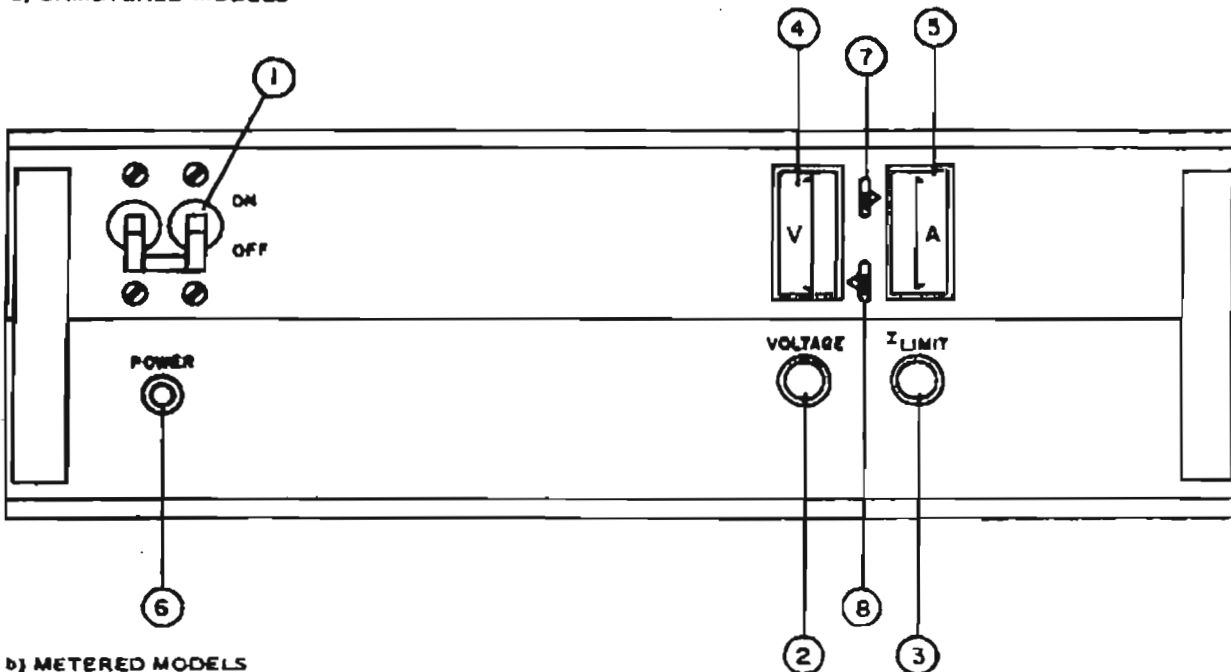

b) METERED MODELS

FIG. 2-3 FRONT PANEL CONTROLS AND TERMINATIONS

NO.	CONTROL OR TERMINATION	FUNCTION
1	AC POWER SWITCH/ CIRCUIT BREAKER	TURNS AC POWER LINE, "ON" OR "OFF" AND PROTECTS POWER SUPPLY INPUT CIRCUITRY
2	VOLTAGE CONTROL	ADJUSTS OUTPUT VOLTAGE FROM ZERO TO $E_0$ max.
3	CURRENT LIMIT CONTROL	ADJUSTS CURRENT LIMIT FROM 0-105% $I_0$ max.
4	VOLTMETER	MONITORS OUTPUT VOLTAGE, 0- $E_0$ max.
5	AMMETER	MONITORS OUTPUT CURRENT 0- $I_0$ max.
6	AC PILOT LIGHT	ENERGIZES WHEN AC POWER IS "ON"
7	METER RANGE SWITCH AMPERE	MAY BE SET TO FULL SCALE READING OF MAXIMUM OR 1/10 OUTPUT
8	METER RANGE SWITCH VOLTS	MAY BE SET TO FULL SCALE READING OF MAXIMUM OR 1/10 OUTPUT

TABLE 2-2 CONTROLS AND TERMINATIONS, FULL-RACK JQE MODELS, FRONT

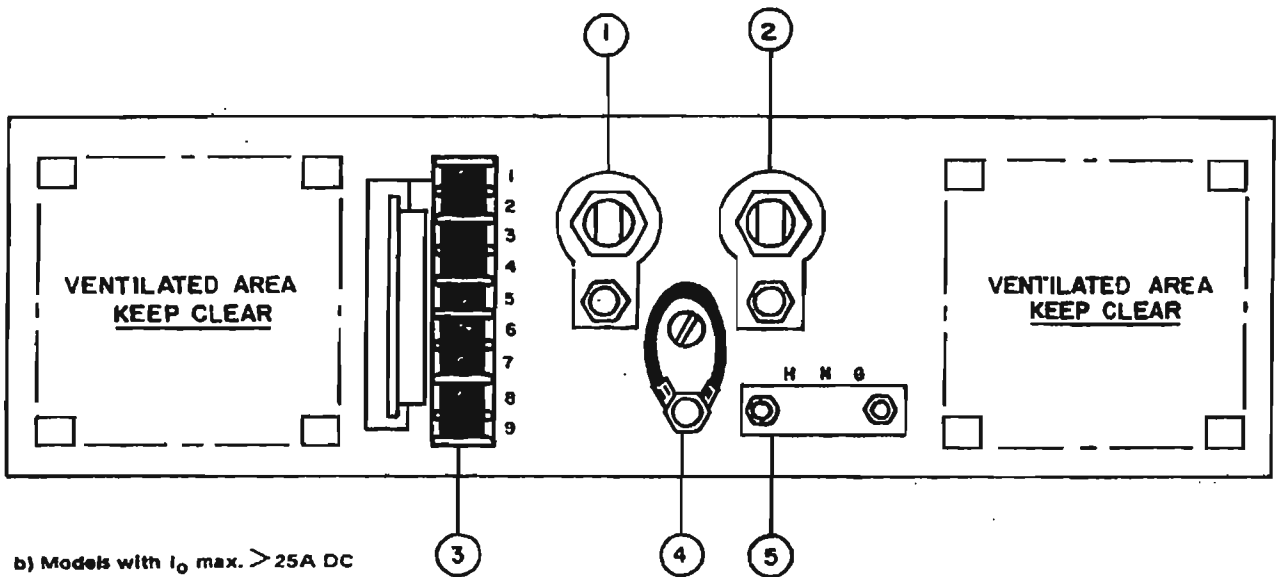
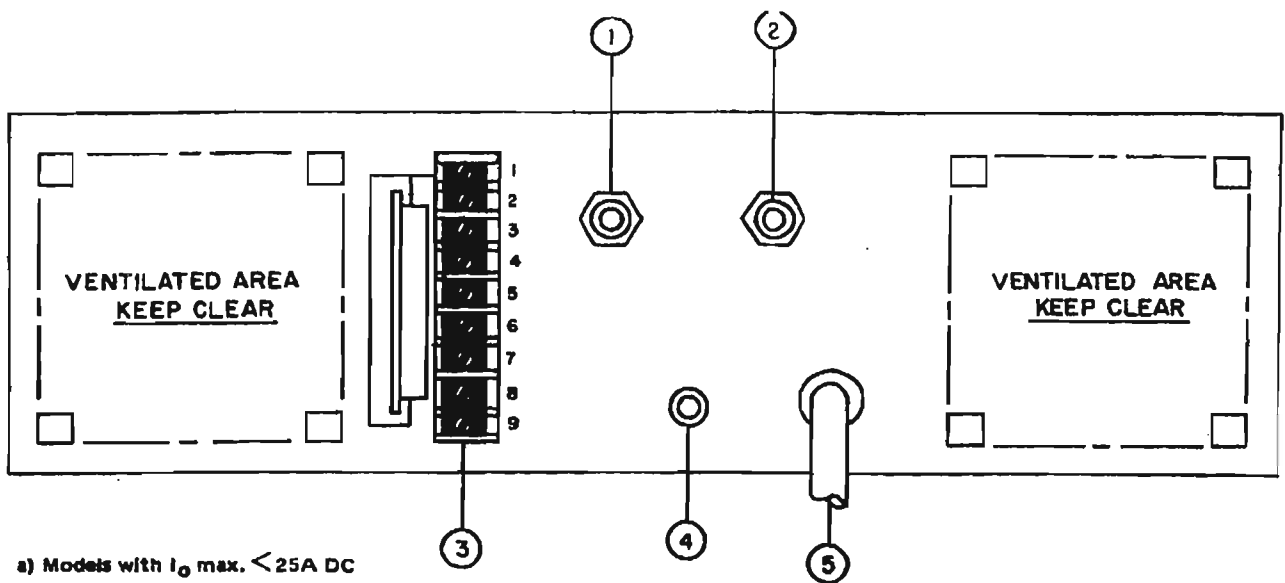
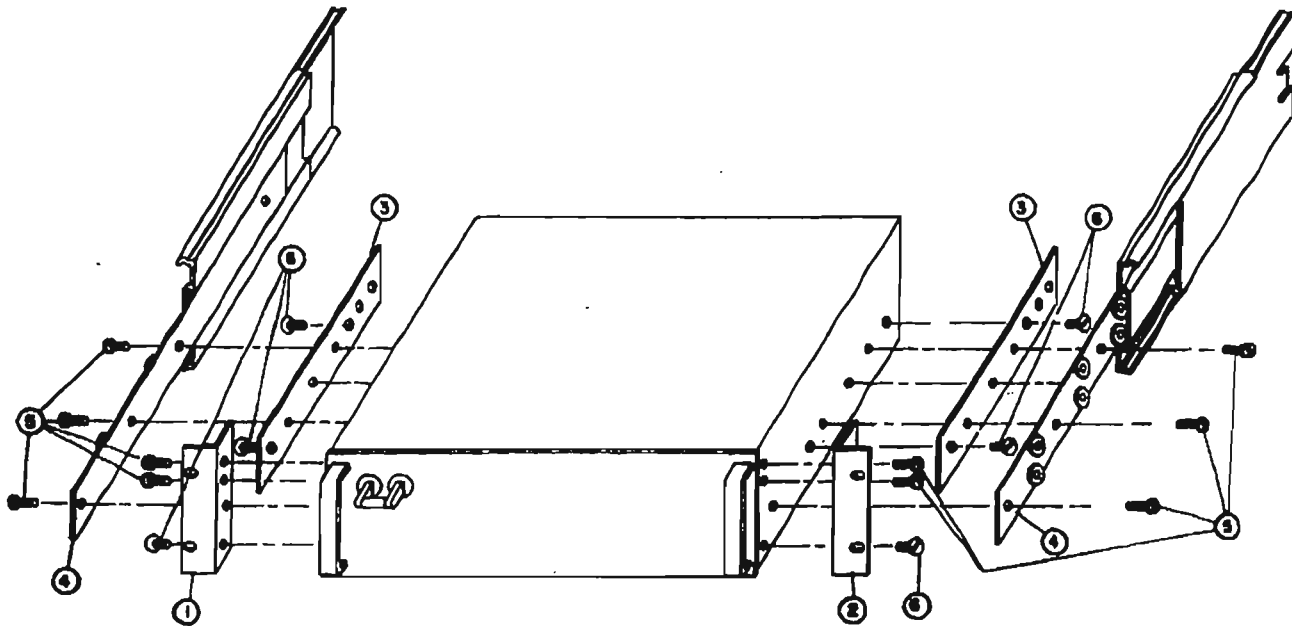

FIG. 2-4 REAR TERMINATIONS, FULL-RACK MODELS

NO.	TERMINATION	FUNCTION
1	(-) OUTPUT	NEGATIVE LOAD TERMINAL WITH GROUNDING POST*
2	(+) OUTPUT	POSITIVE LOAD TERMINAL WITH GROUNDING POST*
3	REAR BARRIER STRIP	PROGRAMMING AND MONITOR TERMINALS: (1) (+) OUTPUT MONITOR (2) (+) ERROR SENSING (3) (-) OUTPUT MONITOR (4) (-) ERROR SENSING (5) INTERNAL VOLTAGE CONTROL (6) NULL JUNCTION (AMPLIFIER INPUT) (7) REFERENCE RESISTOR (8) REFERENCE VOLTAGE (9) REFERENCE RESISTOR
4	CHASSIS CONNECTION	FLOATING GROUND LEAD TO GROUND EITHER (+) OR (-) OUTPUT VIA GROUND POST*
5	AC INPUT	3 WIRE SAFETY LINE CORD (METERED MODELS) OR INPUT BARRIER STRIP

\*Models with  $I_o$  max.  $> 25A$  DC only.

TABLE 2-3 REAR TERMINATIONS, FULL-RACK MODELS



RACK MOUNTING ACCESSORIES, PARTS LIST		
ITEM	DESCRIPTION	QTY.
1	FRONT ANGLE LEFT	1
2	FRONT ANGLE RIGHT	1
3	FILLER BRACKET	2
4	SLIDES: 110 OD JONATHAN SERIES	2
5	10-32 SCR BDG. HD.	10
6	10-32 FLATHEAD 82°	6

NOTE: ITEM (4) NOT SUPPLIED.

#### INSTRUCTIONS FOR SLIDE INSTALLATION

- 1) Items 1, 2, 3 are installed at the factory.
- 2) Item 3 (filler bracket) is predrilled and tapped for Jonathan Slides, Series 110 OD. Remove the three binding head screws on each side of Item 3. (These screws are part of Item 5.)
- 3) Line up slide with filler bracket and reinsert the binding head screws through the appropriate mounting holes in the slide.
- 4) If Jonathan Slide 110 OD-24-1 is used, an additional hole must be drilled into the slide. See FIG. 1-3 for further information.

FIG. 2-5 RACK INSTALLATION, "FULL RACK" MODELS.

NOTE: If slide installation (as described above) is not desired, other means of supporting the unit in the rear must be provided (additional rear brackets or a solid platform, for example) since the front angle brackets (Items 1, 2) alone are not sufficient to support the full weight of the unit.

## SECTION III – OPERATION

### 3-1 STANDARD POWER SUPPLY OPERATION, LOCAL CONTROL

3-2 **GENERAL.** The Power Supply is shipped from the factory with five (5) removable jumper links in place at the rear barrier strip (TB501) as shown in FIG. 3-1. THESE LINKS MUST BE IN PLACE AND SECURED TIGHTLY for standard local operation. Loose terminal links or wires at the barrier strip will cause malfunction of the power supply.

3-3 **LOAD CONNECTION.** The load may be connected in any of the two ways illustrated (FIG. 3-1,3-2). Load connecting wires should be as heavy as practicable, since load wire voltage drops will degrade regulation performance. Twisting of load wires will help to preserve the low output impedance of the power supply. To keep the DC voltage drop in the load connecting wires to a minimum, and to preserve the dynamic characteristics of the power supply (AC stability, output impedance and recovery time), load wires and error sensing leads should be as short and as large in diameter as practicable. Both lead pairs should preferably be tightly twisted. For minimum ripple and noise pick-up, the error sensing leads must be shielded. The shield, as well as one side of the output (preferably the positive), should be returned to the common ground point (Refer to FIG. 3-2).

**CAUTION**

THE LOAD MUST BE CONNECTED TO THE HEAVY DUTY OUTPUT TERMINALS AT THE REAR, NOT TO THE BARRIER STRIP. BARRIER STRIP TERMINALS ARE FOR MONITORING AND PROGRAMMING PURPOSES ONLY.

### 3-4 REMOTE ERROR SENSING

3-5 Specified regulation performance DIRECTLY AT THE LOAD requires the use of remote error sensing. A twisted, shielded pair of wires from the sensing terminals directly to the load will compensate for load wire voltage drops up to 0.5 volt per wire (Refer to FIG. 3-2). Observe polarities: The positive sensing wire [from terminal (2)] goes to the positive load wire.

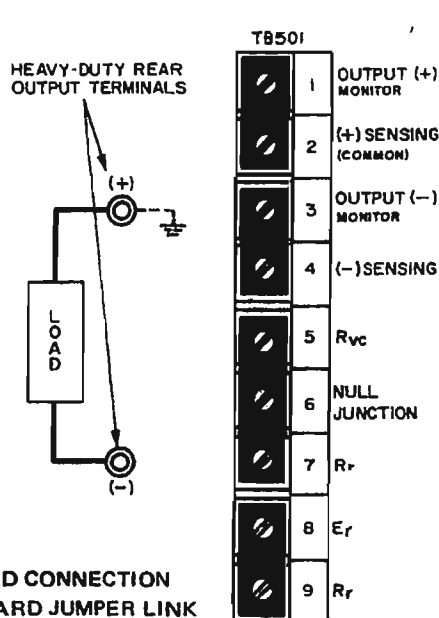

**FIG.3-1 LOAD CONNECTION AND STANDARD JUMPER LINK CONNECTIONS WITHOUT ERROR SENSING**

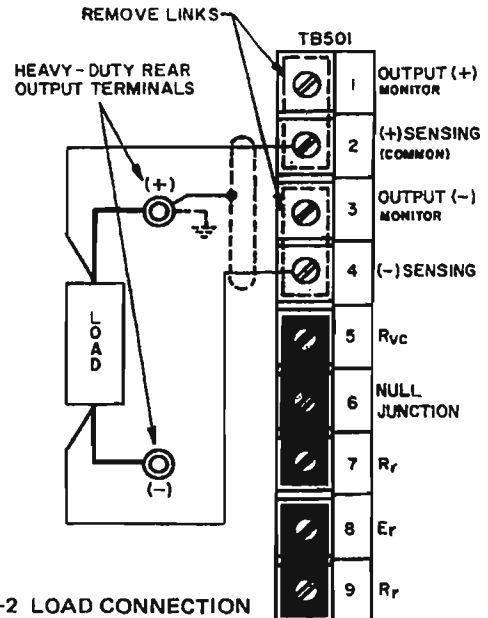

**FIG. 3-2 LOAD CONNECTION USING REMOTE ERROR SENSING**

### 3-6 OUTPUT ADJUSTMENT (Refer to FIG.'s 2-1 and 2-3 for the location of all controls)

- 3-7 a) Once the load is connected to the output terminals of the power supply as described in the previous paragraphs, the operating voltage may be adjusted to the desired value by turning the VOLTAGE CONTROL and observing the panel VOLTMETER.\* The CURRENT LIMIT CONTROL may be set fully clockwise, and will in this position provide over current protection at 105% of the maximum rated output current. The CURRENT LIMIT CONTROL may also be set to intermediate values, as desired, by first turning the AC POWER SWITCH to the "off" position and then placing a short circuit across the output. Turn AC line "on". Now the required operating current is adjusted by turning the CURRENT LIMIT CONTROL to the value needed plus  $\approx 2\%$ . The output current will now limit sharply at this value. After the short is removed from the output, the voltage protector can be set.
- b) (For Models equipped with Voltage Protector only.) With the "V Limit" control set fully clockwise, set the output voltage as described above. Turn the coarse "V Limit" control\*\* (R415) slowly counter clockwise, until the power supply output "crowbars", indicated by the output voltage going to zero and the circuit breaker shutting off. Turn the fine "V Limit" control (R414) slightly clockwise. The amount of "threshold" or difference voltage between operating voltage and the limiting point, is determined by this last adjustment, which should therefore be made with the "fine" control, R414. A too close adjustment towards the operating voltage may lead to spurious triggering, especially if the "delay" adjustment is set for maximum sensitivity. The minimum "threshold" voltage adjustable is 0.5 volt.) Adjust the "delay" capacitor (C413) if required. This control is factory adjusted for maximum sensitivity, consistent with reliable operation without spurious triggering. It needs re-adjustment only if extremely sensitive loads must be triggered in the shortest time possible and if some spurious triggering can be tolerated. Now the load can be connected to the power supply and operation can commence.

\*Use external metering for meterless models.

\*\*If model has only a "fine" control (R414), all VP Adjustments are made with this control.

### 3-8 INTRODUCTION TO REMOTE PROGRAMMING

- 3-9 GENERAL. A few general remarks may be in order to familiarize the user of this equipment with the terminology and basic equations pertaining to remote programming of Kepco Power Supplies. Electrically, the power supply, consists of the unregulated DC source ( $E_U$ ), the pass element ( $E_P$ ), the DC error amplifier (A) and a comparison circuit which resembles a four-arm electrical bridge. (Refer to FIG. 3-3). The elements of the bridge are arranged to produce a virtual zero at the amplifier input when the bridge circuit is at balance ( $V_{AA'} = 0$ ). Any tendency for the output voltage to change in relation to the reference voltage ( $E_r$ ) creates an error signal ( $e$ ) which, by means of negative feedback and the amplifier, tends to correct the output voltage towards restoration of bridge balance.

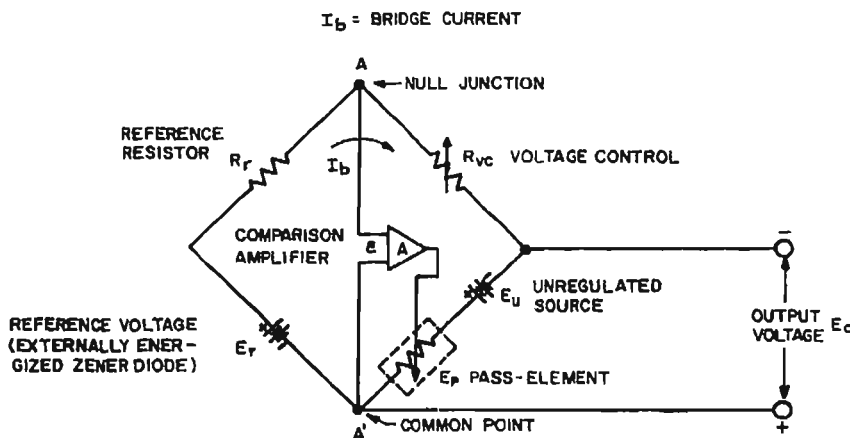

FIG. 3-3 KEPKO POWER SUPPLY CIRCUIT WITH COMPARISON BRIDGE (SIMPLIFIED)



### 3-10 EQUATIONS SHOWING THE OPERATION OF THE KEPSCO BRIDGE

3-11 The following relationships govern the operation of the Kepco Bridge at balance, i.e., with  $V_{AA}' = 0$ :

$$a) \frac{E_o}{E_r} = \frac{R_{vc}}{R_r} \quad (1)$$

Where:  $E_o$  = Output Voltage  
 $E_r$  = Reference Voltage

$$\frac{E_r}{R_r} = I_b \quad (2)$$

$R_r$  = Reference Resistance

$R_{vc}$  = Control Resistance

$$E_o = I_b R_{vc} \quad (3)$$

$I_b$  = Bridge or Control Current

- b) The ratio of the number of ohms control-resistance needed per volt output is termed the "CONTROL RATIO". It is normally 1000 ohm/volt in KEPSCO Power Supplies.
- c) As can be seen from equation (1), the output voltage  $E_o$  can be controlled by varying any one of the three quantities. Rewriting equation (1) we have:

$$E_o = \frac{E_r}{R_r} \times R_{vc}$$

The ratio  $\frac{E_r}{R_r}$  constitutes the bridge or control current  $I_b$ . (Eq. 2).

- d) Therefore, we can write:  $E_o = I_b R_{vc}$  (Eq. 3).  
 Making  $I_b$  a precision quantity (precision bridge current adjustment is described in par. 3-16), establishes a precise programming ratio, so that the accuracy of  $E_o$  is solely dependent upon  $R_{vc}$ . This mode of operation is referred to as "RESISTANCE PROGRAMMING" and is covered in detail in Par. 3-19.

- e) Rewriting equation (1),  $E_o = E_r \frac{R_{vc}}{R_r}$ , we can make  $E_r$  the variable which controls  $E_o$ .

This type of control is referred to as "VOLTAGE PROGRAMMING" and is covered in Par. 3-25.

- f) Many other modes of control are of course possible, some of them are described in the following paragraphs. For a more extensive treatment and a detailed theoretical view of power supply applications see the current KEPSCO Application Literature, available from your Kepco Representative or directly from Kepco Applications Engineering Department.

NOTE: For all programming and adjustment components, use high quality, wire-wound, resistors with a T.C. of 20 p.p.m. or better.

### 3-12 ADJUSTMENTS FOR EXACT PROGRAMMING RATIO\*

- 3-13 Referring to equation (3):  $E_o = I_b R_{vc}$ , it is seen that if  $I_b = 1$  mA, 1000 ohms of control resistance ( $R_{vc}$ ) is needed for each volt of output. Making  $I_b$  therefore a precision quantity the accuracy and linearity of the output voltage will then solely depend upon  $R_{vc}$ .

To allow for the fact that the value of R102 may change over time, use the following procedure to determine the actual  $I_b$  and the corresponding CONTROL RATIO ( $1/I_b$  with  $I_b$  in mA):

1. Turn the unit off and disconnect the unit from source power.
2. Remove the link between positions 5 and 6 of TB 501.
3. Set the Voltage potentiometer on the front panel to full clockwise.
4. Use a precision digital ohmmeter to measure the resistance between positions 4 and 5 of TB 501. This is the actual resistance of the front panel VOLTAGE control (R102), referred to as  $R_{vc}$  Internal.
5. Use the measured value of R102 to calculate  $I_b$  as follows:

$$I_b = (E_o + \Delta E_o) / R_{vc} \text{ Internal}$$

where:

$E_o$  is the nominal output voltage (Volts).

$R_{vc}$  Internal is the value of R102 measured in step 4 (Kilohms).

$I_b$  is the actual control current.

$\Delta E_o$  functions as voltage headroom to allow full scale from the front panel control.

6. Calculate the CONTROL RATIO as  $1/I_b$  (Kilohms/Volt using the value of  $I_b$  (mA) calculated in step 5.
7. Use the calculated values of  $I_b$  and CONTROL RATIO for all procedures of Section III.

As an example, referring to the Procedure: Precision Programming Ratio Adjustment, PAR. 3-16, step c, instead of  $R_{VC} = 5K$  Ohms, use  $R_{VC} = 5(1/I_b)$  (in Kilohms) in order to obtain an output voltage of 5V.

- 3-14 Again referring to equation (3), we see that if  $R_{VC} = 0$  (shorted out), the output voltage should be zero. A small negative offset voltage (in the millivolt range) exists however under this condition at the output.
  - 3-15 Both inaccuracies, the slightly larger bridge current ( $I_b$ ) and the small negative offset voltage ( $E_{i0}$ ) may be adjusted to provide a linear and precise programming ratio. Refer to FIG. 2-1 for the location of the calibration controls.
- 3-16 PROCEDURE. PRECISION PROGRAMMING RATIO ADJUSTMENT (Refer to FIG. 3-4)

a) Equipment Required:

- 1) Precision digital or differential voltmeter (M1).
- 2) Precision resistor, accuracy comparable to M1. The value is not important, but must be known for every 1000 ohms, 1 volt will appear across M1. ( $R_{VC}$ ).
- 3) Single pole, single throw switch (S1).

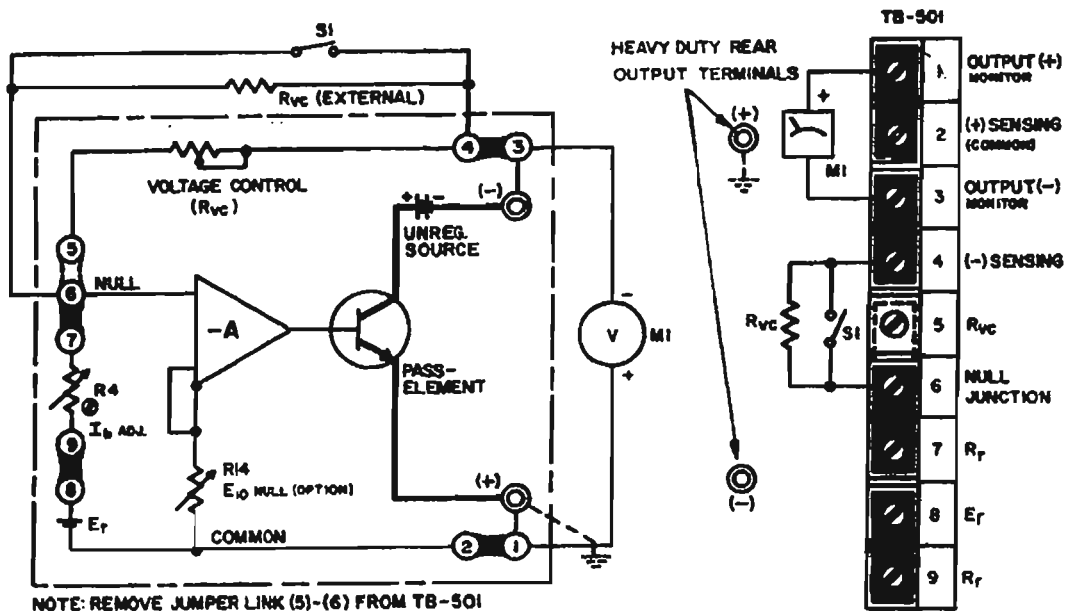

FIG. 3-4 CONNECTIONS FOR PRECISION PROGRAMMING RATIO ADJUSTMENT

- b) Connect calibration set-up as shown in FIG. 3-4 and connect the power supply to the AC power line.
- c) With S1 "open", and  $R_{VC} = 5K$  ohms, approximately 5 volts will be read-out on M1. Adjust R4 ( $I_b$  adjustment) until exactly 5 volts are read-out on M1.
- d) Close S1 and note deviation from zero on M1 (approx. 2 to 8 mV negative). Adjust R14 (zero adjustment) until exactly zero volts read-out on M1.
- e) Open S1 and check the 5 volt reading. Repeat "c" and "d" as necessary to achieve the desired accuracy. FIG. 3-5 below shows graphically how the programming ratio can be precision adjusted.

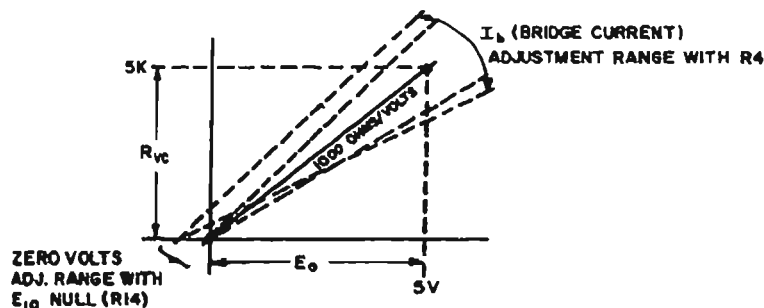

FIG. 3-5 ESTABLISHING PROGRAMMING LINEARITY

### 3-17 GENERAL RULES FOR REMOTE PROGRAMMING

3-18 All remote programming applications require the observance of a few basic rules to insure proper functioning of the power supply in the particular mode of operation selected. These rules should be remembered before each application and especially if malfunctioning of the programming set-up is experienced.

- 1) **GROUNDING.** Ground loops due to multiple and indiscriminant grounding of various equipment are the cause of the majority of complaints about "high ripple or noise". They can be easily avoided by grounding the power supply at one point only to which all shielded cables and equipment cases are connected. If possible, one side (preferable the positive one) of the power supply output should also be grounded. Frequently, high ripple is introduced by programming sources or instruments used at the input (null junction) although all grounding rules have been observed. This may be due to the external instruments or source's close coupling to the AC line. In these cases only isolation (i.e. battery operated devices) is the answer. It must also be remembered that input and output of the power supply are "common", so that if the output is not grounded, the input source must be isolated for the maximum output voltage to be programmed, plus the amount of voltage the common is "off ground".
- 2) **CONNECTIONS.** All external connections, especially the rear barrier strip terminal screws, must be tight. Series malfunctions may be caused by open feedback loops or programming connections.
- 3) **INPUT SOURCES.** If specified performance is expected when remote programming, external input or reference sources must have specifications equal to or better than that of the power supply.
- 4) **PROGRAMMING RESISTORS** Programming resistors should be high quality wirewound units with temperature coefficients of 20 parts per million or better. Their wattage rating must be at least 10 times the actual power dissipated. Although the control current through these resistors is only 1 mA, an error current exists when programming large voltage excursions. The magnitude of this error current equals the change in output voltage, divided by the final resistance of the programming resistor. (If, for example, the voltage step is from 50 volts to zero,  $\Delta E_O = 50$  V) and the final resistance of the programming resistor is  $\Delta R_{VC} = 2$  ohms,  $I_{peak} = 25$  A. The duration of the peak error current depends upon the size of the output capacitor.  $I_{peak}$  decays exponentially as the output voltage assumes the final value.
- 5) **EXTERNAL SWITCHING.** If step-switch devices are used in resistance programming, they must be of the "make before break" variety to avoid programming infinity. Programming resistors must have a voltage rating at least equal to the maximum output voltage of the power supply.

### 3-19 OUTPUT VOLTAGE PROGRAMMING WITH EXTERNAL RESISTANCE

The output voltage of the Power Supply may be controlled remotely by an external resistance, replacing the built-in voltage control resistance which is disconnected at the rear barrier strip. The value of the programming resistance may be calculated by referring to the transfer function derived earlier (Eq.1):

$$E_O = R_{VC} \times \frac{E_r}{R_r}$$

Since  $\frac{E_r}{R_r} = I_b$  (2), it follows that  $E_O = I_b R_{VC}$  (3)

Referring to Equation (3), we see that since  $I_b$  is 1 mA in KEPCO Power Supplies (and can be precisely adjusted as shown in Par. 3-12), for every volt of output, 1000 ohms control resistance must be provided. This corresponds to a "Programming Ratio" of 1000 ohms per volt.

### 3-20 PROCEDURE (Refer to FIG. 3-6)

- a) Determine value of programmin resistor(s) for output voltage desired.
- b) Using two-wire, shielded cable, connect the chosen resistors to terminals (4) and (6). Connect the shield to the "ground" terminal.
- c) The output voltage will vary from zero to  $(1 \text{ mA}) \times (R_{VC})$ , as  $R_{VC}$  is adjusted from zero to its maximum value.

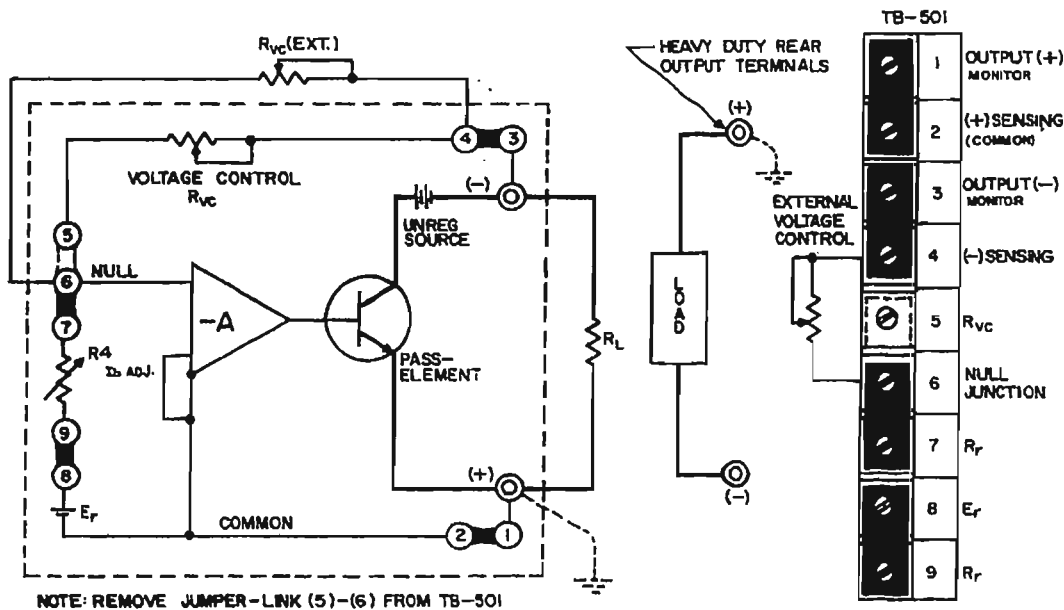

FIG. 3-6 REMOTE RESISTANCE PROGRAMMING

### 3-21 PROGRAMMING BY CONDUCTANCE:

3-22 For special applications, the output voltage  $E_O$  can be adjusted by varying the bridge current. The relationship governing this type of programming is:

$$E_O = E_r (R_{VC}) (G), \text{ (Eq. 4)} \quad \text{Where: } G = \frac{1}{R_r + R_x} = \text{programming conductance}$$

or

$$E_O = \frac{E_r}{R_r + R_x} \times (R_{VC})$$

- $E_O$  = output voltage
- $E_r$  = reference voltage
- $R_{VC}$  = control resistance
- $R_r$  = reference resistance
- $R_x$  = programming resistor

Since  $\frac{E_r}{R_r} = I_b$  and  $E_O = I_b R_{VC}$ , the output voltage varies directly as  $I_b$  changes. Changing  $I_b$  with the help of an additional resistor in series with  $R_r$  results in an inversely proportional change of  $I_b$ , since now

$$I_b = \frac{E_r}{R_r + R_x}$$

This method of output voltage adjustment is therefore referred to as conductance programming.

3-23 Conductance programming is a reciprocal function when analyzed in terms of resistance, but perfectly proportional

$$E_O \propto \frac{1}{R_x}$$

It can be very useful, especially over a limited range and for small changes in output voltage. Another distinctive advantage of this type of programming is the "built-in" safety feature. Should the programming circuit open accidentally, the programming resistance becomes infinite, the conductance is zero, and consequently, the output voltage becomes zero.

### 3-24 PROCEDURE (Refer to FIG. 3-7)

EXAMPLE:  $E_O$  desired = 3 to 5 volts.

a) Select  $R_{VC}$  for maximum desired output voltage  $E_O$ .

$$R_{VC} = \frac{E_O}{I_b}; R_{VC} = \frac{5V}{1 \text{ mA}} = 5 \text{ K ohms.}$$

Set built in  $R_{VC}$  to 5 K ohms, or disconnect and use external resistor.

b) A change of  $E_O$  to 3 volts requires a bridge current change of:

$$\Delta I_b = \frac{\Delta E_O}{I_b} = \frac{2 \text{ volts}}{5 \text{ K ohms}} = .4 \text{ mA}$$

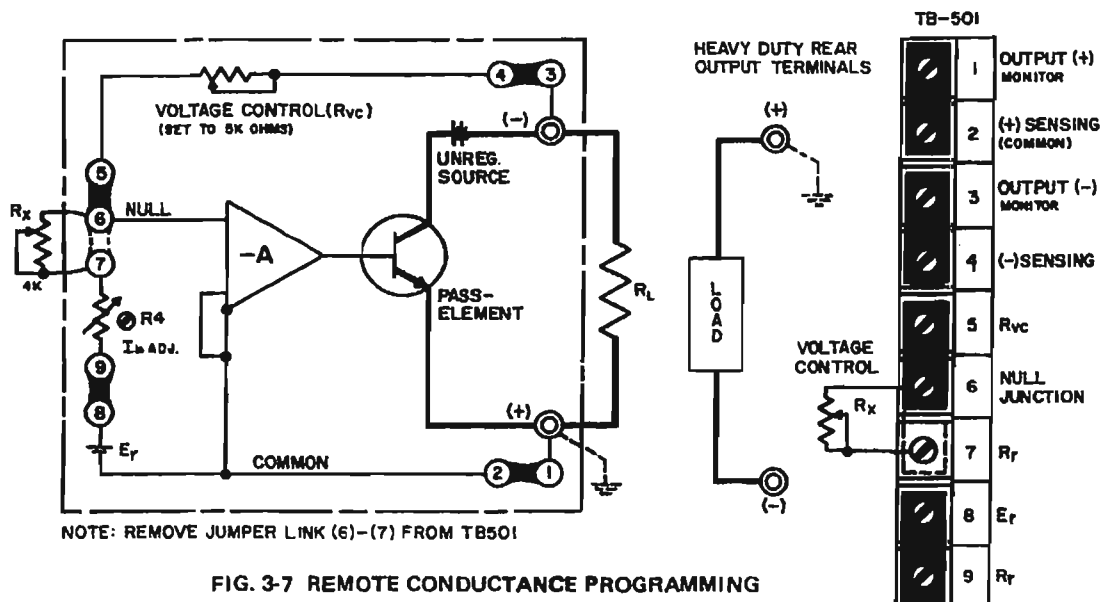

**FIG. 3-7 REMOTE CONDUCTANCE PROGRAMMING**

c) Since  $I_b = \frac{E_r}{R_r} = 1 \text{ mA}$ , the additional resistance needed is:

$$I_b (R_r + R_x) = E_r; R_x = \frac{E_r}{I_b} - R_r \text{ or } R_x = \frac{6 \text{ volts}}{0.6 \text{ mA}} - 6 \text{ K} = 4 \text{ K ohms.}$$

A 4K ohm, WW, low T.C. potentiometer, connected as shown in FIG. 3-7, will change the output voltage from 3 to 5 volts when varied from zero to 4K ohms.

NOTE: A word of caution may be in order in regard to the changing of the bridge current. The 1 mA value has been selected for maximum stability in the zener reference circuit. A large departure from this value is not advisable. If a  $\pm 50\%$  change in  $I_b$  is not sufficient to achieve the desired voltage swing, an external reference supply can be used.

**3-24A INTERNAL ADJUSTMENT PROCEDURES**

3-24B GENERAL. This paragraph describes all internal adjustment procedures, which have not been previously covered. Refer to Section II, paragraph 2-3 for a listing and location of all adjustment procedures.

3-24C MAXIMUM OUTPUT CURRENT ("I<sub>o</sub> max. adj.") ADJUSTMENT. This adjustment serves as a calibration for the range of the front panel Current Limit Control. The "I<sub>o</sub> max. adj." (R19) is located on the printed circuit board (Refer to FIG. 2-1). It is factory set so that the front panel control covers an output current range of 2-105% of the maximum rated output current. Re-adjustment of the "I<sub>o</sub> max. adj." control is to be restricted. A convenient way to make the adjustment is as follows:

- a) Load the output of the supply to draw the maximum output current of 105% of rated output current with the front panel Current Limit Control fully clockwise. Monitor the output voltage with an oscilloscope having a vertical sensitivity of at least 0.1mV/cm.
- b) Observe the oscilloscope. Current limiting is indicated by a sharp increase in output ripple. Locate the "I<sub>o</sub> max. adj." control and turn slowly until limiting occurs at the point required. Clockwise adjustment will increase the maximum output current range, while counterclockwise adjustment will decrease the range. DO NOT ADJUST TO MORE THAN 105% I<sub>o</sub> max. Although this might be possible due to component tolerances, malfunction of the power supply will be caused by exceeding the rated maximum output current.

3-24D LAG NETWORK ADJUSTMENTS. With most models in the JQE series it is necessary to shape the gain-phase characteristics of the error-signal amplifier with external compensation networks, to achieve stability for any amount of feedback. Since gain and phase shift differ from model to model, either one or two adjustable lag networks are provided (R16-C9 and/or R36-C10,\*). Lag network readjustment is indicated if components affecting the frequency characteristics of the amplifier are replaced, or if the load connected to the power supply contains excessive capacity or inductance, causing instability. The instability is usually indicated by high frequency oscillation as observed with an oscilloscope across the power supply load. In such cases, the lag network should be adjusted so that stable operation is resumed. If in extreme cases adjustment of the lag network should not prove sufficient, twisted-load and error-sensing wires or decoupling capacity directly across the load may provide a solution to the problem.

\*C12 in Model JQE 6-90.

3-24E AMMETER ZERO ADJUST (MODEL JQE 6-90M ONLY). A meter amplifier is connected between the sensing resistor and the ammeter to reduce the loading effect on the sensing resistor. Offset control of the meter amplifier is used to achieve perfect zero of the ammeter. Adjustment of this control should be needed only in cases where either the meter amplifier or the ammeter is replaced.

**3-25 REMOTE PROGRAMMING WITH EXTERNAL CONTROL VOLTAGE**

3-26 The output voltage of KEPCO power supplies may be controlled by an external, variable voltage source, which supplies the necessary control current, formerly delivered by the (now disconnected) internal, fixed reference source. This mode of operation is termed "Voltage Programming". It can be mathematically expressed by referring to basic equation (1):

$$\frac{E_o}{E_r} = \frac{R_{vc}}{R_r} \text{ (Eq. 1) Solving for } E_o, \text{ and designating the external programming components "E}_i, R_i\text{"}$$

the result is: 
$$E_o = -E_i \times \frac{R_{vc}}{R_i} \text{ (Eq. 5)}$$

3-27 As seen from the expression (Eq.5), if the ratio  $R_{vc}/R_i$  (which represents the closed loop gain of the system) is held constant,  $E_o$  will vary linearly with  $E_i$ , the external programming voltage. The above expression (Eq.5) is seen to be similar to the operational amplifier transfer function in the inverting configuration. The voltage programmed power supply does in fact become a unipolar power amplifier with potentially very high power gain but with limited frequency response. (Refer to FIG. 3-8). The limited frequency response is largely due to the effect of the output capacitor ( $C_o$ ) acting as a low-pass filter and preventing the output voltage ( $E_o$ ) from varying rapidly. The output voltage may be varied over the full range, bounded on the high end by the maximum rated value. A practical example to illustrate component selection will be given below.

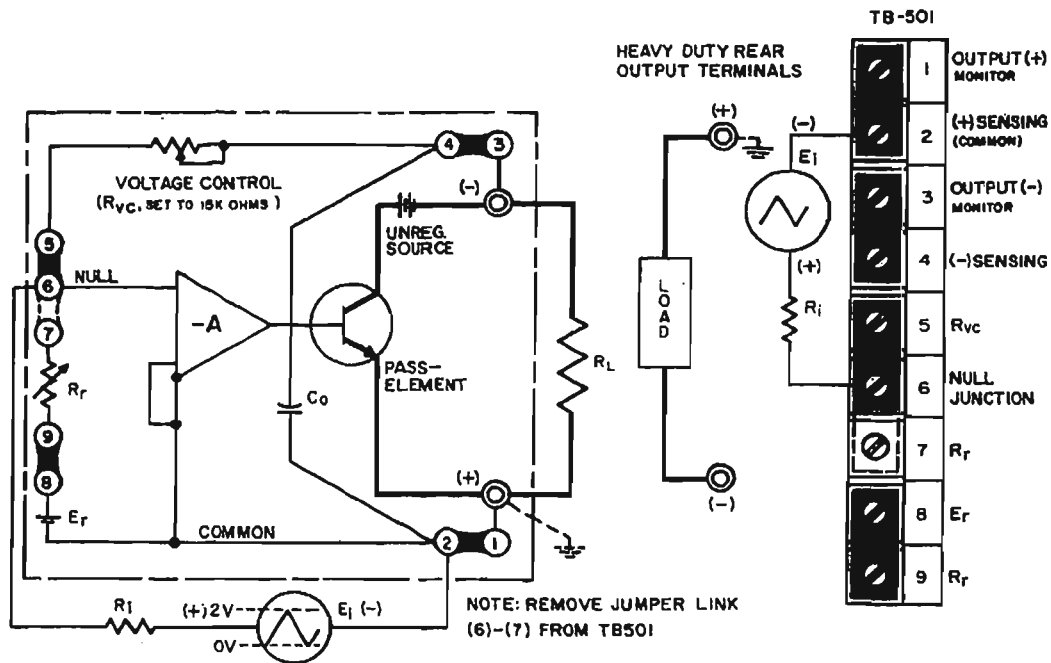

FIG. 3-8 THE POWER SUPPLY IN THE OPERATIONAL AMPLIFIER MODE

3-28 Example: A power supply with a rated maximum output voltage of 15 volts is to be voltage programmed over its full range (0 to 15V) by a triangular, positive increasing source with a peak output voltage ( $E_i$ ) of 2 volts, and able to deliver at least 1 mA control current. Since the required voltage gain is:  $E_o/E_i = 15/2 = 7.5$ , the ratio  $R_{vc}/R_i$  must also equal 7.5. If the internal voltage control is retained, in this case, since  $R_{vc} = 15 \text{ K ohms}$ ,  $R_i$  must equal  $15 \text{ K}/7.5 = 2 \text{ K ohms}$ . FIG. 3-8 shows the Power Supply as an operational amplifier and the necessary rear barrier connections for this mode of operation.

**3-29 CONSTANT CURRENT OPERATION**

**3-30** A KEPCO power supply can be set up to deliver constant current by the addition of an external sensing resistor and a current control. In the constant current operating mode, the voltage comparison bridge is interconnected with an external current sensing resistor,  $R_S$ , and a current control,  $R_{CC}$  (as shown in FIG. 3-9) to maintain a constant voltage drop across  $R_S$ . In this way, an adjustable constant load current is obtained. Characteristic of the constant current supply is ability to change its output voltage automatically in order to maintain a constant current through a range of possible load resistances. The range of output voltage that the supply can deliver and simultaneously maintain constant current, is referred to as the "COMPLIANCE VOLTAGE".

**3-31** The current sensing resistor  $R_S$  is chosen to develop a 0.5 volt drop at the maximum desired current.\* It is calculated by dividing this current into 0.5 volt. The value of  $R_S$  is not critical and can be the nearest standard resistance available. Several facts should be kept in mind however, when choosing  $R_S$ . A compromise must be made between a large and a small value. While a large value is desirable for good current regulation, it is less so in view of the power dissipated across it. It must be remembered that all the load current is flowing through  $R_S$  and the input to the regulator is connected across it. It is therefore vital that all extraneous changes across  $R_S$ , i.e. resistance change due to temperature, are kept to a minimum. A high quality, low T.C. (20 PPM) resistor, at least ten times the actual wattage needed, is therefore strongly recommended. In practice,  $R_S$  is usually selected for a 0.5 volt sample at maximum output current desired.\* If more than a 10:1 ratio of output current is needed, several values of  $R_S$  should be selected and switched in or out as required.

\*For KEPCO Power Supplies with maximum rated output currents of 5 A DC or less, a 1 volt sample at the maximum desired current should be used.

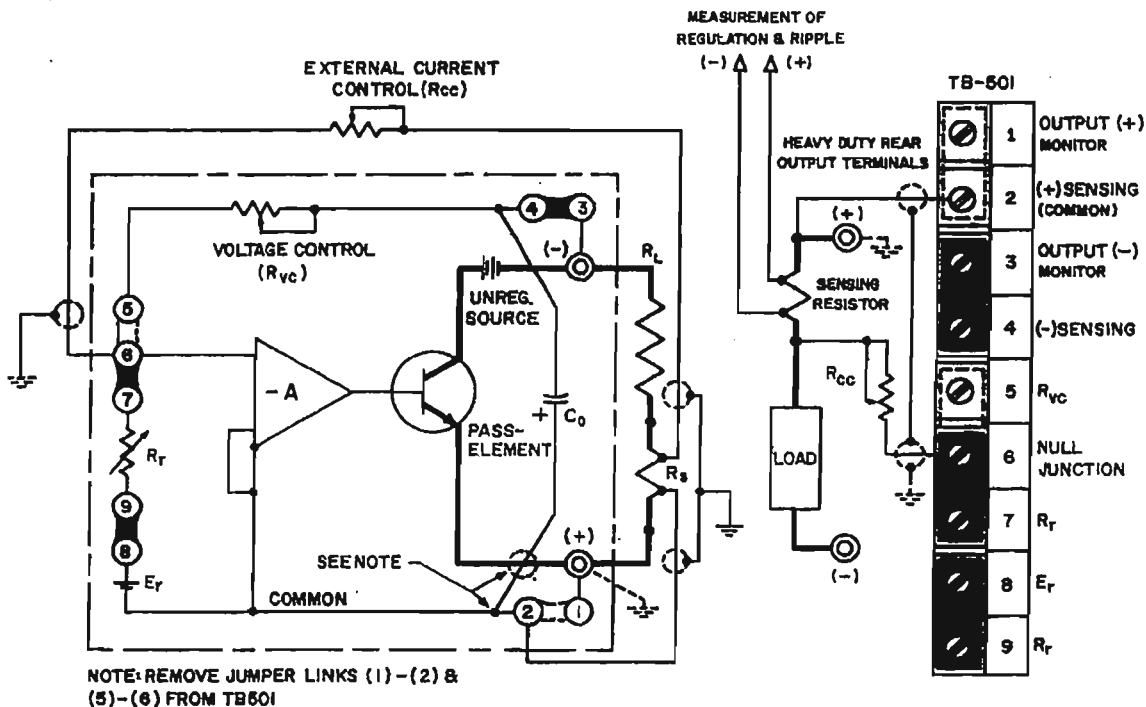

**FIG. 3-9 CONSTANT CURRENT OPERATING MODE**

**NOTE:**  $R_S$  should be physically located as close to the (+) output terminal of the power supply as possible. If, however, long output and sensing leads cannot be avoided, the (+) terminal of the output capacitor ( $C_O$ ) must be internally reconnected from the (+) sensing to the (+) output terminal.

3-32 The current control resistor,  $R_{CC}$  is chosen on the basis of the control ratio of the Kepco comparison bridge, and  $V_S$  the maximum voltage across  $R_S$ . If  $R_S$  was selected for 0.5 volt drop, then  $V_S = 0.5$  volt and  $R_{CC} = V_S$  times (control ratio), or

$$R_{CC} = 0.5 \text{ volt} \times \frac{1000 \text{ ohm}}{\text{volt}} = 500 \text{ ohms. A high quality, low T.C. (20 PPM) resistor is recommended}$$

for  $R_{CC}$ .

3-33 PROCEDURE (Refer to FIG. 3-9)

The actual component calculation for current regulation is perhaps best shown by a practical example. A KEPCO Power Supply with a rated maximum output current of 50 A DC is to be set up for current regulated output from 5A to 50A (1:10 ratio).

a)  $R_S$  is chosen by:  $R_S = \frac{0.5 \text{ volt}}{50 \text{ A}} = 0.01 \text{ ohm.}$

$$P_{diss} = V_S \times I_{max.} = 0.5 \text{ volt} \times (50 \text{ A}) = 25 \text{ watts. (use 250 watt)}$$

NOTE: A heavy duty, 4 terminal meter shunt or a power resistor in the TEPRO "TMK" series is required. Inquire at KEPCO if special values are needed.

b) The control resistance  $R_{CC}$  is found by calculating its limits:

$$R_{CC} \text{ (max.)} = V_S \text{ (max.)} \times \text{control ratio} = 0.5 \text{ V} \times \frac{1000 \text{ ohms}}{\text{V}} = 500 \text{ ohms.}$$

$$R_{CC} \text{ (min.)} = V_S \text{ (min.)} \times \text{control ratio} = 0.05 \text{ V} \times \frac{1000 \text{ ohms}}{\text{V}} = 50 \text{ ohms.}$$

As  $R_{CC}$  is therefore varied from 50 ohms to 500 ohms, the regulated current will vary from 5 to 50 mA. The compliance voltage will change in the same ratio (10:1), its absolute value depending on the load resistance used.

c) A large output current range (1 mA to 50 A) could be covered if three separate sensing resistors were to be calculated on the basis of a 0.5 volt sample at maximum current:

a)  $R^1_S$  (For 5 to 50 A) =  $0.5 \text{ V}/50 \text{ A} = 0.01 \Omega$  (250 watt)

b)  $R^2_S$  (For 0.5 to 5 A) =  $0.5 \text{ V}/5 \text{ A} = 0.1 \Omega$  (25 watt)

c)  $R^3_S$  (For 0.05 mA to 0.5 A) =  $0.5 \text{ V}/0.5 \text{ A} = 1 \Omega$  (2.5 watt)



### 3-34 SERIES OPERATION OF KEPCO POWER SUPPLIES

3-35 GENERAL. Kepco Power Supplies can be series-connected for increased voltage output, provided the specified limits on voltage to chassis are not exceeded. When series-connected, the supplies should be protected by means of a semiconductor diode across the output terminals of each power supply, as shown in FIG. 3-10. The peak inverse rating of these diodes must be at least as large as the output voltage of the supply to which they are connected. The continuous current rating of the diodes should be at least as great as the largest short-circuit current of the interconnected supplies.

3-36 Two basic series connection methods are generally used, the "Automatic Series Connection", as illustrated in FIG. 3-10, and the "Master-Slave" connection, shown in FIG. 3-11. The basic difference between these two alternate methods lies in the manner of the output control. While in the "Automatic" connection the outputs of both supplies may be controlled individually, in the "Master-Slave" connection, control is exercised from the "Master" supply alone, while the "Slave" supply follows the master command in a ratio which may be pre-determined by the user. The latter method of series operation is therefore frequently termed "Automatic Tracking".

### 3-37 PROCEDURE FOR AUTOMATIC SERIES CONNECTION

- a) Connect load as shown in FIG. 3-10. Keep voltage drop in load wires as low as practical by using heavy gauge wire.
  - b) Connect protective diodes across respective output terminals.
  - c) Remove jumpers as shown and connect error sensing leads. These leads should also be as heavy as practicable, and should be twisted and shielded.
  - d) Turn supplies on and adjust voltage on either control as required.
- 3-38 The "Master-Slave" series connection method is illustrated in FIG. 3-11. As seen from the figure, the reference voltage ( $E_r$ ) of the "Slave" supply is disconnected and its input or null junction is connected to the output of the "Master" supply via the tracking resistor ( $R_t$ ). The "Slave" supply output is thus completely dependent on the "Master" output voltage:

$$E_{os} = E_{om} \frac{R_{vcs}}{R_t}, \text{ where: } \begin{array}{l} E_{om} = \text{Output Voltage, Master} \\ E_{os} = \text{Output Voltage, Slave} \\ R_t = \text{Tracking Resistor} \\ R_{vcs} = \text{Voltage Control Resistance, Slave} \end{array}$$

As evident from the equation above, if the tracking resistor ( $R_t$ ) value is equal to that of the voltage control resistor of the "Slave" supply ( $R_{vcs}$ ), a "tracking ratio of 1:1 is achieved and the output of the "Slave" will equal that of the "Master". If a single load is connected to the series "Master-Slave" combination, twice the "Master" output voltage is applied to it. If separate loads are connected, identical voltages are applied to the individual loads.

3-39 The ratio  $E_{os}/E_{om}$  can be readily changed if the application so requires by simply altering the value of either  $R_{vcs}$  or  $R_t$ . In practice, since  $R_{vcs}$  is the ten-turn voltage control rheostat of the "Slave" supply, the tracking resistor ( $R_t$ ) is selected for the desired tracking ratio. The value of  $R_{vcs}$  is determined from the parts list and  $R_t$  is selected accordingly to the selected ratio. For a 1:1 ratio  $R_t = R_{vcs}$ , for a 1:2 ratio,  $R_t = 1/2 R_{vcs}$  etc.

### 3-40 PROCEDURE FOR MASTER-SLAVE SERIES CONNECTION

- a) Connect load as shown in FIG. 3-11. Keep voltage drop in the load wires as low as possible by using heavy gauge wire.
- b) Connect protective diodes across the respective output terminals.
- c) Remove jumper links as shown (FIG. 3-11) and connect error sensing leads if remote sensing is desired. Sensing leads should be twisted and shielded.
- d) Select value of the tracking resistor ( $R_t$ ) and connect with shielded wire as shown (FIG. 3-11).
- e) Turn supplies "on", and adjust output voltage on the "Master" Voltage Control as desired.

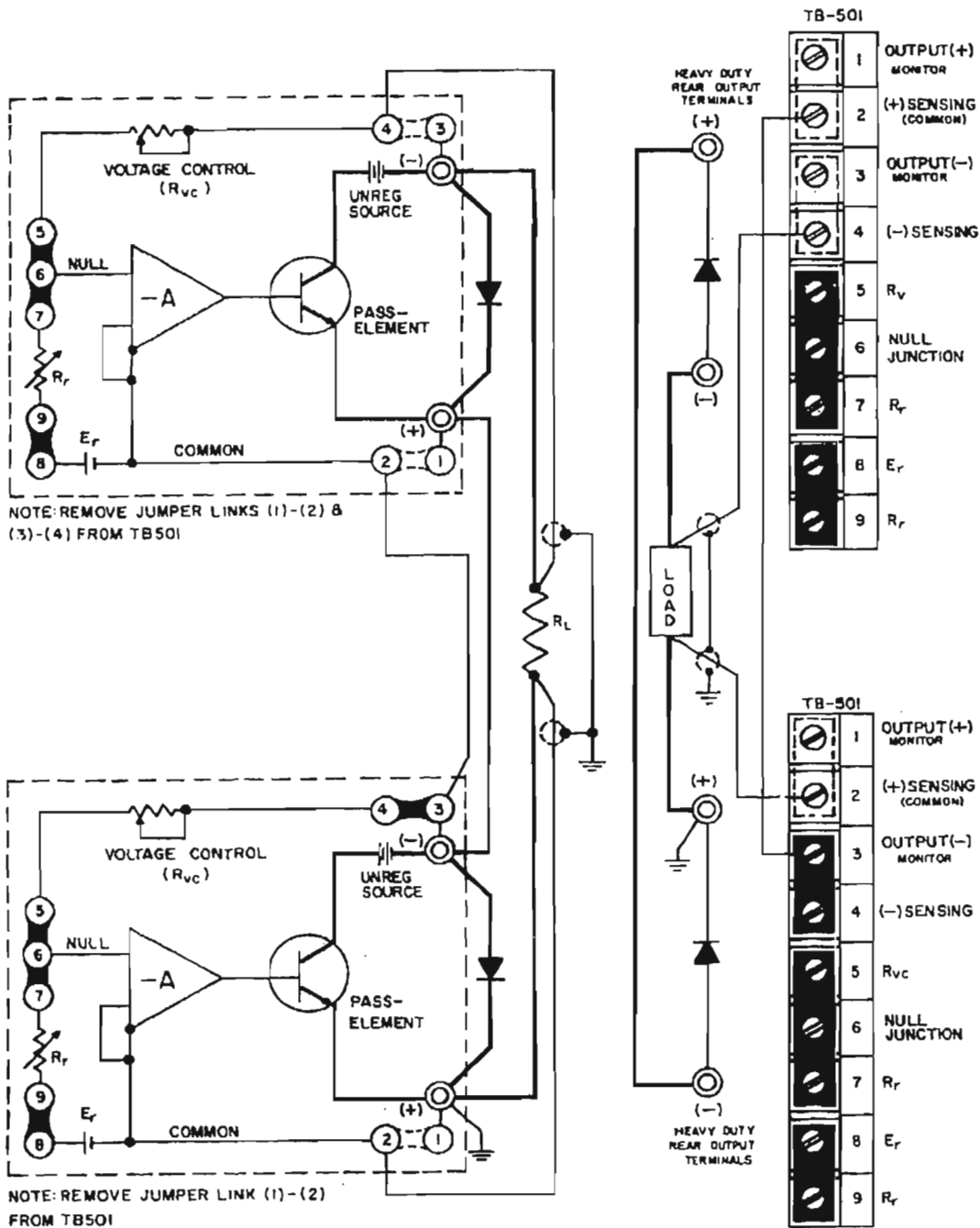

FIG. 3-10 AUTOMATIC SERIES CONNECTION OF KEPKO POWER SUPPLIES

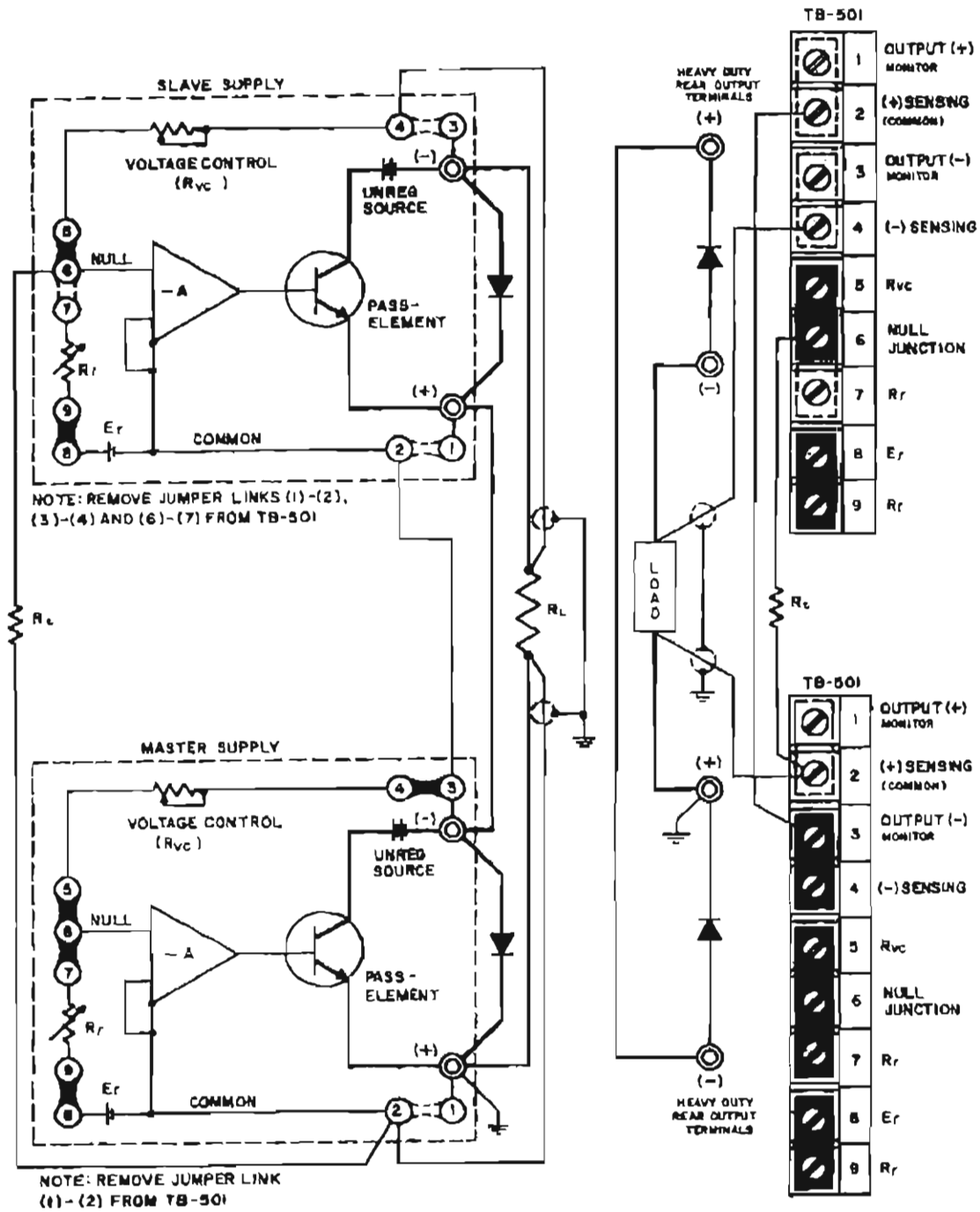

FIG. 3-11 MASTER-SLAVE SERIES CONNECTION OF KEPKO POWER SUPPLIES

### 3-40A PARALLEL OPERATION

**GENERAL.** Kepco power supplies equipped with an overvoltage crowbar (all CPS models and JQE models with suffix "VP") cannot be operated in parallel for increased output current. A triggered crowbar in a power supply working in a parallel configuration would have to absorb the total output current of the other power supplies.

**EMERGENCY SITUATIONS.** Sometimes a situation arises where additional output current is required and only power supplies with lower than required current ratings are available. In these cases, the power supplies can be paralleled if the crowbar circuit in each unit is disabled. Refer to the component location drawing for assembly A4 (Section VI of this manual) and remove R402 from the overvoltage protector assembly (A4). If overvoltage protection is considered essential in the application at hand, a separate crowbar circuit, rated for the *total* output current in the parallel connected power supplies must be used. (Refer to Kepco VIP models.) Two basic methods of paralleling power supplies are described in pars. 3-41 to 3-46. **USE PARALLELING IN EMERGENCIES ONLY. CROWBAR CIRCUITS MUST BE DISABLED.**

#### 3-41 PARALLEL OPERATION (AFTER DISABLING THE CROWBAR CIRCUIT ONLY)

3-42 **GENERAL.** As in the previously described "series" connections, an "Automatic" or a "Master/Slave" connection method can be chosen. The choice between the two methods will depend on the application at hand. For constant loads or small load variations (load changes *smaller* than the maximum output range of a *single* power supply), the "Automatic" parallel connection can be used. For load changes *exceeding* the maximum rating of a *single* power supply, the "Master/Slave" method is suitable. For either method, some general rules should be observed:

- 1) Parallel *only* supplies which can be adjusted to the same compliance (output) voltage.
- 2) Error sensing, as shown in the following diagrams, can be used to compensate for load wire voltage drops.
- 3) Load wires should be *as short as practicable*. Select wire gauge *as heavy as possible* and twist wires tightly. Approximately *equal* lengths of wire should be used.
- 4) *Common* a-c power source "turn-off" for all supplies is recommended.

#### 3-43 AUTOMATIC PARALLEL CONNECTION

3-44 PROCEDURE FOR AUTOMATIC PARALLEL CONNECTION (See FIG. 3-13)

- 1) Connect the power supplies to be paralleled to a common a-c source (preferably with a common "on-off" power switch).
- 2) *Without* connecting the power supplies to the load or to each other, turn a-c power "on," and adjust the output voltage on each supply to the required compliance voltage.
- 3) Adjust *both* "current" controls to their maximum (extreme clockwise) position. Turn a-c power "off."
- 4) Make all load interconnections as shown in the connection diagram (refer to FIG. 3-13) *except the error sensing connections* (these connections may be added later if needed).
- 5) With the *individual* a-c power switches of the two power supplies in the "on" position, turn *common* a-c power switch "on." Observe output current meters on *both* units. Since the initial output voltage adjustments were not identical, *one* of the power supplies (to be designated SUPPLY #1) will be at a slightly higher output voltage than the other (to be designated SUPPLY #2). Consequently SUPPLY #1 will deliver its maximum load current and will operate in the current limit mode. The rest of the load current is delivered by SUPPLY #2, which is operating in the voltage mode.

- 6) The "current" control of SUPPLY #1 can now be adjusted, as to equalize the total load current between SUPPLY #1 and SUPPLY #2, and operation can proceed. ERROR SENSING CAN BE USED FROM SUPPLY #2 ONLY.

**NOTE:** The diagram below (refer to FIG. 3-12) shows how the two power supplies operate in the parallel mode. As seen from FIG. 3-12, load variations should be confined within the stabilization region of SUPPLY #2 since there is an initial adjustment error ( $\Delta E_O$ ) between the two supplies.

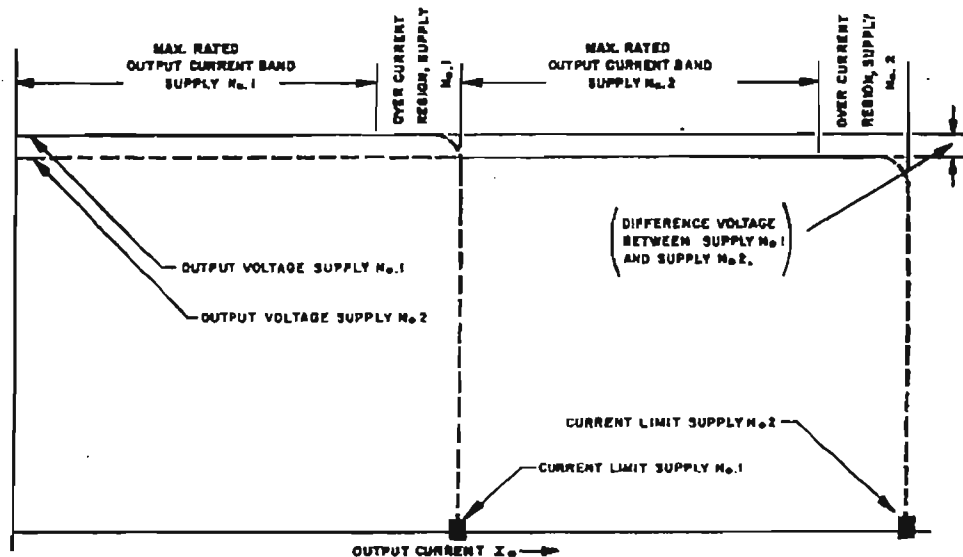

FIG. 3-12 "AUTOMATIC" PARALLEL OPERATION (TWO SUPPLIES).

3-45 **MASTER/SLAVE PARALLEL CONNECTION.** Two power supplies are shown in FIG. 3-14, although more can be paralleled, each unit requiring its own sampling resistor. The sampling resistors ( $R_{S1}$ ,  $R_{S2}$  in FIG. 3-14) are of equal value and are selected such that the voltage drop across them (due to the output current), plus the voltage drop in the load connection leads does never exceed 0.5 volts. If the voltage drop across the load connecting leads alone is at least 0.1 volt, the sensing resistors can be deleted since the leads provide the necessary sample voltage. For equal current sharing, however, the lead *length* and *diameter* should be the same for both power supplies. Output control is exercised from the "Master" supply.

3-46 PROCEDURE FOR "MASTER/SLAVE" PARALLEL OPERATION (See FIG. 3-14)

- 1) Connect the power supplies to be paralleled to a common a-c source (preferably with a common "on-off" power switch).
- 2) Make all load and sensing connections as shown in FIG. 3-14. The error sensing connections may be deleted if the minor voltage drop across the load wires (which subtracts from the available compliance voltage) can be tolerated.
- 3) With the *individual* a-c power switches of the two power supplies in the "on" position, turn the *common* a-c power switch "on." Observe output panel meters on both power supplies. Adjust output control on the "Master" supply, such that both supplies share the load current equally.

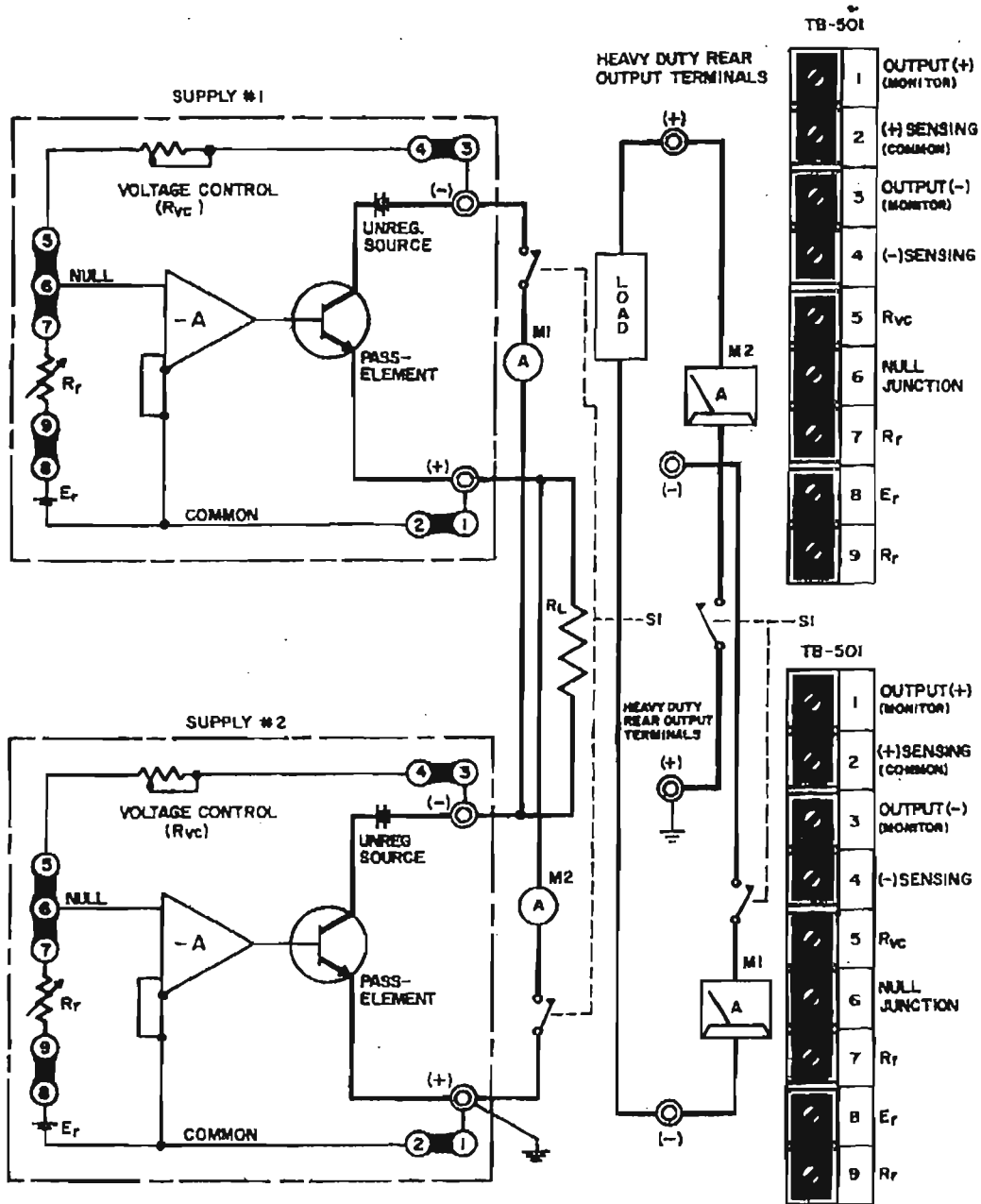

FIG. 3-13 BASIC PARALLEL CONNECTION OF TWO KEPCO POWER SUPPLIES

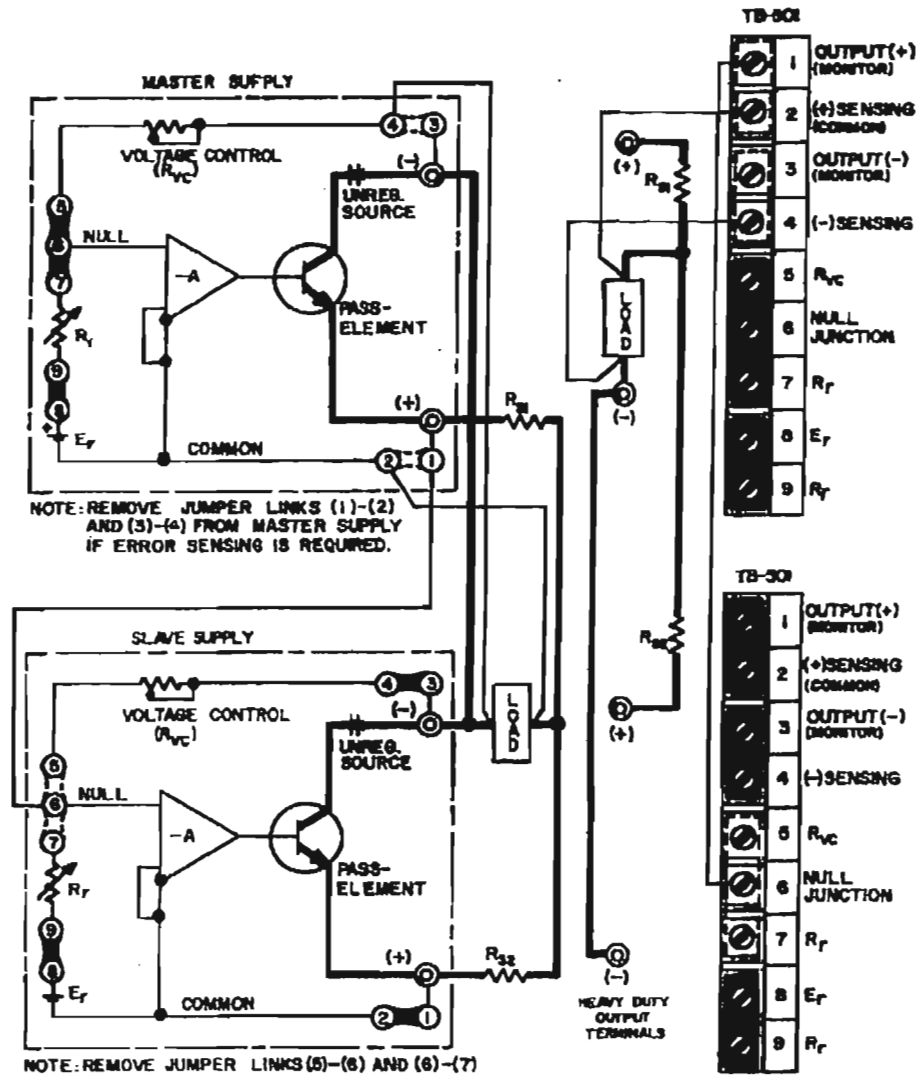

FIG. 3-14 MASTER SLAVE PARALLEL CONNECTION OF KEPKO POWER SUPPLIES

