

# INSTRUCTION MANUAL

## GROUP EFX 050-T AND 100-T

### POWER SUPPLY

40 ~ 50kHz - 4 OUTPUT  
SWITCHING POWER SUPPLIES

KEPCO INC.  
An ISO 9001 Company.

<b>MODEL</b>		
<b>EFX 050-T, 100-T</b>		
<b>POWER SUPPLY</b>		
<input type="text" value="ORDER NO."/>	<input type="text" value="REV. NO."/>	

**NOTE** This on-line version of the Technical Manual includes only installation and operating instructions. For the complete manual, please contact Kepco.

©2000, KEPCO, INC.



**KEPCO®**

**THE POWER SUPPLIER™**

KEPCO, INC. 1 131-38 SANFORD AVENUE 1 FLUSHING, NY. 11352 U.S.A. 1 TEL (718) 461-7000 1 FAX (718) 767-1102  
email: [hq@kepcopower.com](mailto:hq@kepcopower.com) 1 World Wide Web: <http://www.kepcopower.com>

## TABLE OF CONTENTS

PARAGRAPH	PAGE
<b>SECTION I—INTRODUCTION</b>	
1-1 Scope of Manual.....	1-1
1-3 Description.....	1-1
1-7 Specifications .....	1-2
<b>SECTION II—INSTALLATION AND OPERATION</b>	
2-1 Unpacking and Inspection .....	2-1
2-4 Repacking for Shipment.....	2-1
2-6 Input Source Selection .....	2-1
2-8 Fuse Change.....	2-1
2-10 Installation.....	2-1
2-12 Load Connections .....	2-3/2-4
<b>SECTION III—THEORY OF OPERATION</b>	
3-1 Circuit Description.....	3-1
Simplified Diagram Discussion .....	3-7/3-8
<b>SECTION IV—MAINTENANCE</b>	
4-1 General .....	4-1
4-3 Periodic Maintenance.....	4-1
4-5 Performance Measurements .....	4-1
4-15 Trouble Shooting.....	4-3
4-25 Repair and Replacement.....	4-14
<b>SECTION V—ELECTRICAL PARTS LIST AND DIAGRAMS</b>	
5-1 General.....	5-1/5-2
5-3 Ordering Information.....	5-1/5-2

## LIST OF ILLUSTRATIONS

FIGURE	PAGE
1-1 Kepco EFX Series Open Frame Switching Power Supply .....	iii/iv
1-2 Derating Graph for Operation from 50°C to 71 °C .....	1-3/1-4
2-1 EFX Power Supply, Simplified Top View .....	2-1
2-2 Mechanical Outline Drawing .....	2-2
2-3 Recommended Load Connections (Diagram) .....	2-3/2-4
3-1 Input Filter and Off-Line Rectifier with B + Filter (Diagram).....	3-1
3-2 Starting Circuit and Auxiliary Power Supply (Diagram) .....	3-2
3-3 Simplified Schematic Diagram, Forward Converter Circuit (General) .....	3-2
3-4 EFX Forward Converter Circuit (Diagram) .....	3-3
3-5 Sensing Circuit with Voltage Error Amplifier(Diagram) .....	3-4
3-6 Current Limit Circuit (Diagram) .....	3-6
3-7 Simplified Schematic Diagram, EFX Series.....	3-7/3-8
4-1 Application of 4-Terminal Network Technique for Measuring Output Effects (Diagram).....	4-1
4-2 General Trouble Shooting Flow-Chart .....	4-7/4-8
4-3 Switching Wave Forms for EFX Power Supply (Graph).....	4-9/4-10
4-4 Flow Chart for Wave Form Analysis.....	4-11/4-12
4-6 Output Ripple and Noise (Graph) .....	4-13
5-1 Component Location, EFX Power Supply .....	5-21/5-22
5-2 Schematic Diagram, EFX Power Supply.....	5-23/5-24

## LIST OF TABLES

TABLE	PAGE
1-1 Output Ratings, EFX Series .....	1-1
1-2 Output Stabilization.....	1-2
1-3 Output Cross Stabilization .....	1-2
1-4 Output Ripple and Noise .....	1-3/1-4
4-1 Trouble Shooting Data .....	4-4
4-2 Miscellaneous Trouble Shooting Data .....	4-5/4-6

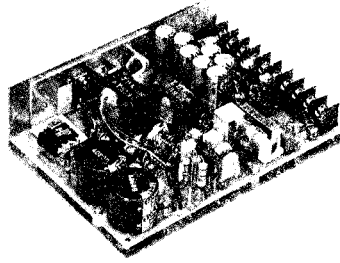

50 Watt

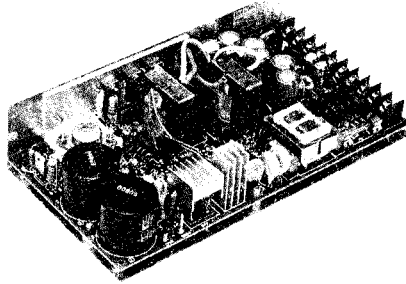

100 Watt

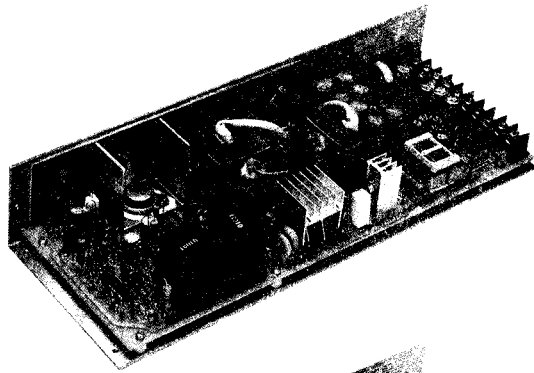

150 Watt

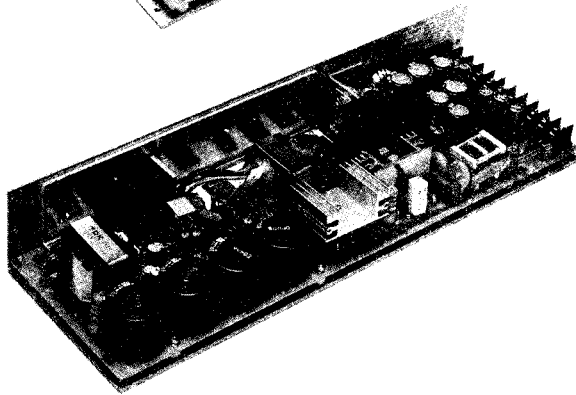

210 Watt

FIG. 1-1 THE EFX GROUPS OF SWITCHING POWER SUPPLIES

## SECTION I—INTRODUCTION

### 1-1 SCOPE OF MANUAL

1-2 This manual contains instructions for the installation, operation and maintenance of the Kepco Series EFX Switch Mode Power Supplies.

### 1-3 DESCRIPTION

- 1-4 The EFX power supply series consists of several groups of switching power supplies, having one principal output of 5 volts and three (3) auxiliary outputs of various ratings, as listed in Table 1-1.
- 1-5 All EFX models will operate from single phase a-c power lines, in the range from 100 to 130V a-c or, by setting an internal source selector, in the range from 200 to 260V a-c. All EFX models have soft start circuits to prevent excessive input surge current. They are protected at the input as well as on each output against short circuits by means of fuses. In addition, a current limit circuit reduces the output voltage, if the output power rating is exceeded by more than 30%. A protective circuit guards the principal output against voltage surges by shutting down the unit if an overvoltage occurs.
- 1-6 The EFX power supply is of the "Open Frame" construction and can be mounted on either one of its two mounting surfaces. All inputs and outputs are terminated on a single, heavy duty barrier strip. Single board construction and clear identification of all components on the printed circuit board should be helpful if servicing becomes necessary.

MODEL	TOTAL POWER	PRINCIPAL OUTPUT V <sub>1</sub> (+5V)		AUXILIARY OUTPUTS					
		VOLTS	AMPS	V <sub>2</sub> (V <sub>1</sub> )		V <sub>3</sub> (V <sub>2</sub> )		V <sub>4</sub> (V <sub>3</sub> )	
				VOLTS	AMPS	VOLTS	AMPS	VOLTS	AMPS
EFX 050T-1	50W	+ 5V	6.0A	+ 24V	0.2A	+ 12V	1.0A	- 12V	1.0A
EFX 050T-2	50W	+ 5V	6.0A	+ 24V	0.2A	+ 15V	1.0A	- 15V	1.0A
EFX 050T-3	50W	+ 5V	6.0A	- 5V	0.8A	+ 12V	1.0A	- 12V	1.0A
EFX 050T-4	50W	+ 5V	6.0A	- 5V	0.8A	+ 15V	1.0A	- 15V	1.0A
EFX 100T-1	100W	+ 5V	8.0A	+ 24V	0.5A	+ 12V	2.0A	- 12V	2.0A
EFX 100T-2	100W	+ 5V	8.0A	+ 24V	0.5A	+ 15V	1.6A	- 15V	1.6A
EFX 100T-1	100W	+ 5V	8.0A	- 5V	1.5A	+ 12V	2.0A	- 12V	2.0A
EFX 100T-1	100W	+ 5V	8.0A	- 5V	1.5A	+ 15V	1.6A	- 15V	1.6A

TABLE 1-1 OUTPUT RATINGS, EFX SERIES

*NOTE: Output designations in parentheses are for older EFX models. Refer to Section II, FIG. 2-1 to determine if you have an older or a new EFX version.*

TABLE 1-1 OUTPUT RATINGS, EFX SERIES.

**1-7 SPECIFICATIONS:**

- A) INPUT SOURCE VOLTAGE: 100 to 130V a-c or 200 to 260V a-c, 47 to 440 Hz, single phase.  
BROWNOUT VOLTAGE: 90V a-c/180V a-c. The EFX power supply will function at the brownout level with minor degradation in the specifications for ripple, stabilization and holding time.
- B) INPUT SOURCE CURRENT AT 25 °C.

	MAXIMUM <sup>(1)</sup>	TYPICAL <sup>(2)</sup>	TYPICAL INPUT SURGE
EFX 050T SERIES:	1A / 2A	0.9A / 1.8A	15A / 7.5A
EFX 100T SERIES:	1.4A / 2.8A	1.2A / 2.4A	15A / 7.5A
EFX 150T SERIES:	2.1A / 4.2A	1.8A / 3.6A	15A / 7.5A
EFX 210T SERIES:	2.9A / 5.8A	2.5A / 5.0A	15A / 7.5A

<sup>(1)</sup> MEASURED AT 200/100V a-c INPUT VOLTAGE AND FULL LOAD (50 °C LEVEL).

<sup>(2)</sup> MEASURED AT 230/115V a-c INPUT VOLTAGE AND FULL LOAD (50 °C LEVEL).

- C) INPUT PROTECTION AND SOFT START: All EFX power supplies are protected at turn-on by a fuse against short circuits in the input circuit. A soft start circuit prevents excessive input surge current.
- D) EFFICIENCY: Greater than 70%.
- E) OUTPUT RATINGS: See Table 1-1.
- F) OUTPUT ADJUSTMENT RANGE: ± 10%, Principal Output only; Auxiliary Outputs are fixed. The location of the output adjustment rheostat is shown in Section II, FIG. 2-1.
- G) CURRENT LIMIT AND SHORT CIRCUIT PROTECTION: Each of the four (4) outputs is protected against short circuits by means of a fuse on the printed circuit board, see FIG. 2-1. An internal current limit is activated when the total output power exceeds the rated power by 30%.
- H) OUTPUT SETTING ACCURACY: All auxiliary outputs are within ± 5% of their tabulated value when the principal output is set to the nominal value (5 volts) and the power supply is fully loaded.
- J) OUTPUT STABILIZATION: Refer to Table 1-2

INFLUENCE QUANTITY	PRINCIPAL OUTPUT		AUXILIARY OUTPUTS	
	Typ.	Max.	Typ.	Max.
SOURCE EFFECT (Min-Max)	<0.1%	0.5%	<0.5%	1.0%
LOAD EFFECT (20-100%)	<0.2%	1.0%	<5.0%	10.0%
TEMPERATURE EFFECT (0-50°C)	<0.5%	1.0%	<0.5%	1.0%
COMBINED EFFECT (Envelope)	<0.8%	2.5%	<6.0%	12.0%
TIME EFFECT (drift, 8 hr @ 25°C)	<0.02%	0.1%	<0.02%	0.1%

TABLE 1-2 OUTPUT STABILIZATION.

- K) OUTPUT CROSS STABILIZATION: See Table 1-3.

**NOTE:** This specification expresses the influence on each of the outputs when the load on another output is changed by the amount listed.

OUTPUTS	Typ.	Max.
PRINCIPAL OUTPUT (Change any output 20-100% of rated load):	0.2%	0.5%
AUXILIARY (Change principal output 50-100% of rated load):	3%	6%
AUXILIARY (Change load on any output, other than the principal output, 20-100% of rated load):	1%	2%

TABLE 1-3 OUTPUT CROSS STABILIZATION.

- L) OUTPUT RECOVERY FROM LOAD CHANGES (ALL OUTPUTS): A step load change from 50 to 100% of the rated load current produces less than 5% output voltage excursion (or 0.5 volt, whichever is greater). Recovery occurs to within 0.5% (or 0.05 volt whichever is greater) of the original output voltage setting in less than 5 milliseconds. Stepload rise or fall time must be greater than 5 microseconds.
- M) OUTPUT RIPPLE AND NOISE (ALL OUTPUTS): See Table 1-4.

FREQUENCY	PRINCIPAL OUTPUT		AUXILIARY OUTPUTS	
	Typ.	Max.	Typ.	Max.
2x Source frequency	25mV p-p	50mV p-p	50 mV p-p	100mV p-p
2x Switching frequency	50mV p-p	100mV p-p	50mV p-p	100mV p-p
Spike Voltage (to 10MHz)	1% E <sub>o</sub> + 50mV p-p max.		1% E <sub>o</sub> + 50mV p-p max.	

TABLE 1-4 OUTPUT RIPPLE AND NOISE.

- N) OUTPUT HOLDING TIME: On a-c input interruption or failure, the d-c output will be maintained for a minimum of 20 milliseconds (30 ms typical) at full load and nominal input source.
- O) OVERVOLTAGE PROTECTION: The principal output is monitored by a sensing circuit with a threshold setting between 6.0 to 6.9 volt. An overvoltage above the threshold value will shut down the principal oscillator and thereby reduce all outputs to zero volts.  
**NOTE: THE OVERVOLTAGE CIRCUIT IS RESET BY INTERRUPTING THE A-C INPUT FOR APPROXIMATELY 10 TO 40 SECONDS.**
- P) AMBIENT OPERATING TEMPERATURE RANGE: 0° to 71°C.  
**NOTE: No derating for 0°C to 50°C operation. For operation to 71°C, output current for all outputs must be derated linearly from 50°C to 71°C to a value of 40% at 71°C, see FIG. 1-2.**
- Q) STORAGE TEMPERATURE RANGE: -25°C to +75°C.
- R) ISOLATION (At 20°C ambient temperature, 65% relative humidity).  
 Between input and output terminals: 2.5KV a-c for 1 minute.  
 Between input terminals and chassis: 2.5KV a-c for 1 minute.  
 Between output terminals and chassis: 500V d-c, 100 megohm.
- S) VIBRATION: 5-10 Hz, 10 mm amplitude, 3 axes.  
 10-55 Hz, 2G, 3 axes.  
 SHOCK: 20G, 3 axes, 11 ± 5 milliseconds pulse duration.

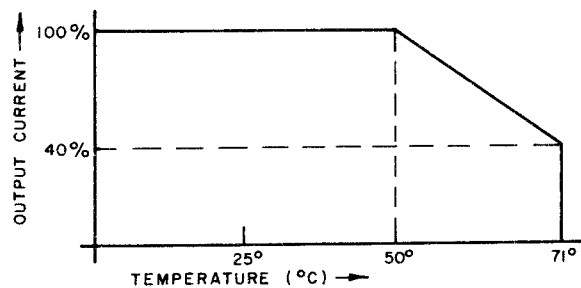

FIG. 1-2 DERATING GRAPH: USE FOR OPERATION FROM 50°C-71°C AMBIENT TEMPERATURE.

## SECTION II—INSTALLATION AND OPERATION

### 2-1 UNPACKING AND INSPECTION

2-2 **MECHANICAL CHECK.** The Kepco EFX power supply has been inspected and tested prior to packing and is ready for installation and operation. Before permanent installation, the unit should be inspected for shipping damage. If such damage is found, retain the original shipping container and notify the responsible carrier.

2-3 **ELECTRICAL CHECK.** The unit should be checked electrically, by doing the **PERFORMANCE MEASUREMENTS** as described in Section IV paragraphs 4-5 through 4-14.

### 2-4 REPACKING FOR SHIPMENT

2-5 To insure safe shipment, repack unit into its original shipping container.

**NOTE: DO NOT SHIP PARTS OR INSTRUMENTS TO KEPKO UNLESS AUTHORIZATION TAGS AND INSTRUCTIONS HAVE BEEN PROVIDED. Contact your Kepco Sales Representative for instructions.**

### 2-6 INPUT SOURCE VOLTAGE SELECTION

2-7 All EFX power supplies can be operated on a-c, single phase power lines (47 to 440 Hz). The units are normally delivered for operation on a 100 to 130 a-c source. For operation on a 200 to 260V a-c source, remove the wire jumper from the "115" position and reconnect it to the "230" position, see FIG. 2-1.

### 2-8 FUSE CHANGE (See FIG. 2-1)

2-9 All fuses are located on the printed circuit board and are clearly marked with fuse number and value. The relationship between the outputs and their fuse number is shown in FIG. 2-1.

### 2-10 INSTALLATION (See Mechanical Outline Drawing, FIG. 2-2)

2-11 The EFX power supply may be mounted and operated in any position. Two mounting surfaces are provided, as shown in FIG 2-2. Care should be taken that the air immediately surrounding the power supply does not exceed the specified ambient temperature. Cooler power supply operation can often be achieved by mounting the unit onto a heat conducting surface. For operation in ambient temperatures greater than 50°C, linear derating of the output current must be applied, see Section I, paragraph 1-7P.

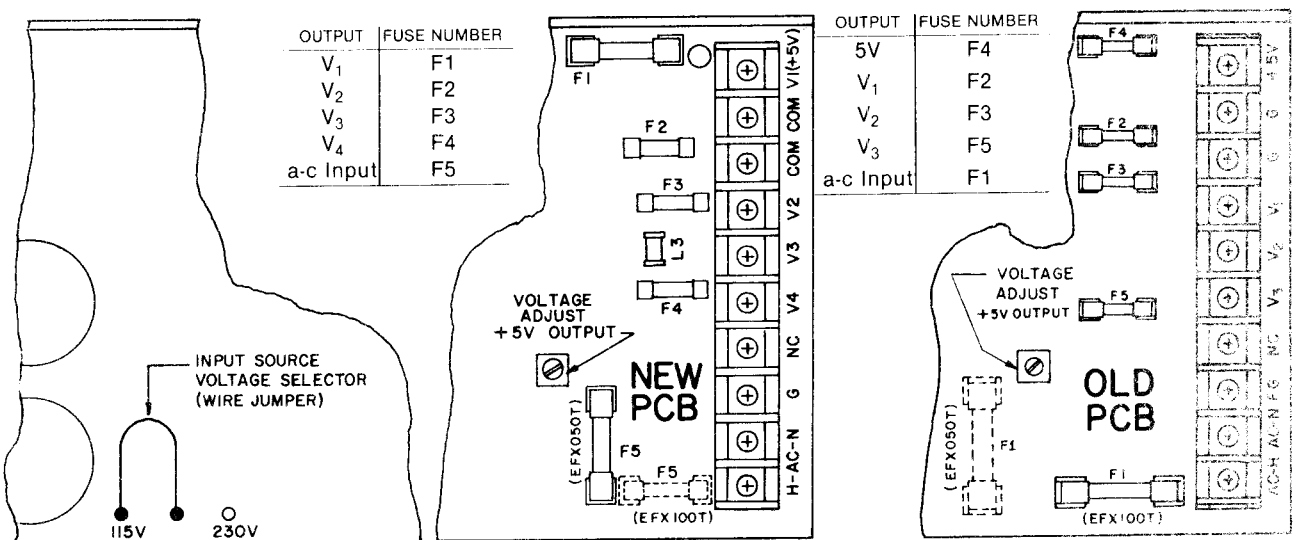
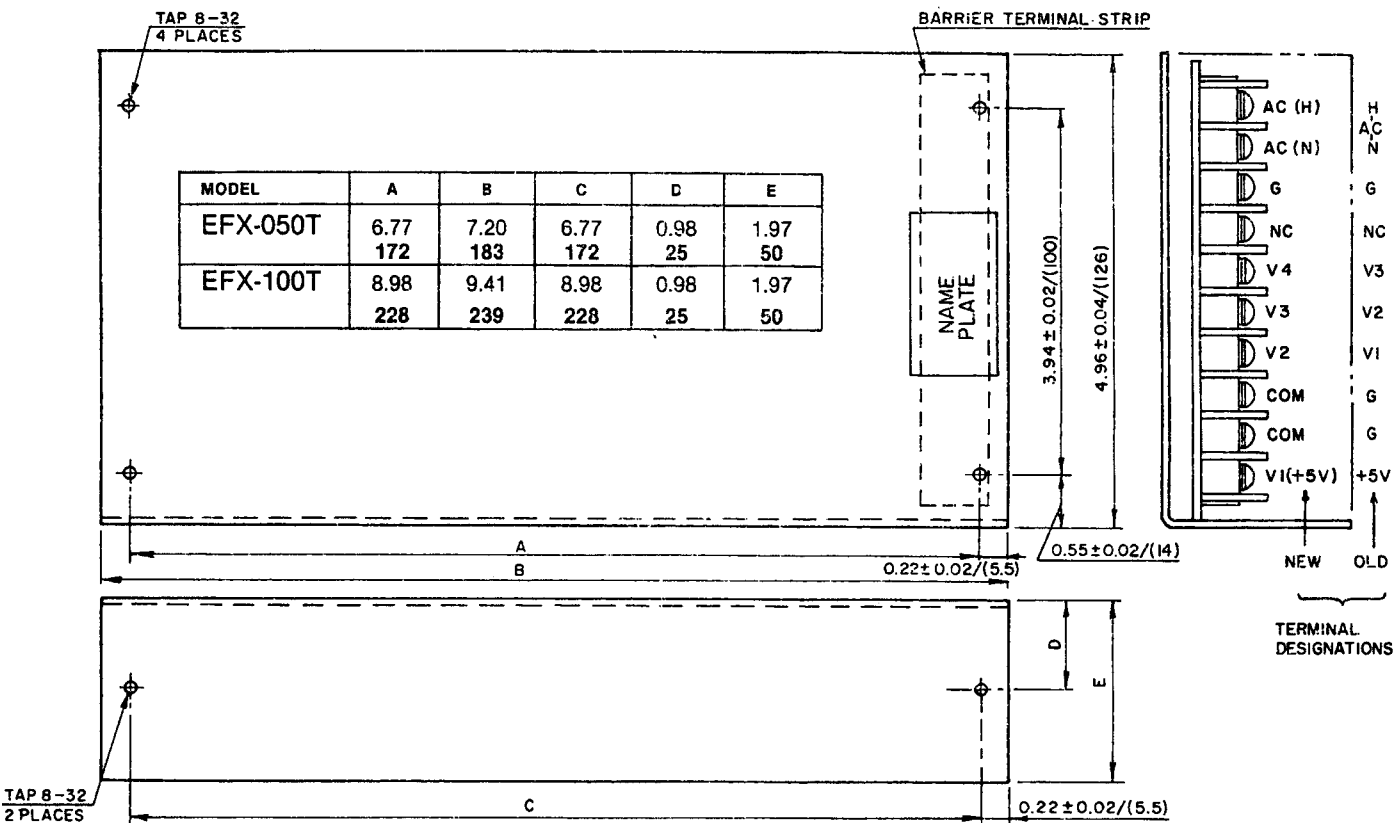

FIG. 2-1 EFX POWER SUPPLY, SERIES EFX 050T AND EFX 100T SIMPLIFIED PARTIAL TOP VIEWS, SHOWING THE LOCATION OF THE INPUT SELECTOR (LEFT), TERMINATIONS AND FUSES (RIGHT).





- Notes: 1) Dimensions (in light type) are in inches. Dimensions (in bold type) are in millimeters.
- 2) TOLERANCES: 0.02" (0.5 mm) between mounting holes, 0.04" (1.0 mm) other dimensions.
- 3) Maximum mounting screw penetration:  $\frac{1}{8}$  inch.
- 4) Chassis Material & Finish: Phosphate treated aluminum.
- 5) Weight: EFX 050T: 0.9 Kg./1.98 Lbs.  
EFX 100T: 1.2 Kg./2.65 Lbs.

FIG. 2-2 MECHANICAL OUTLINE DRAWING, EFX 050T AND EFX 100T SERIES.

## 2-12 LOAD CONNECTIONS

- 2-13 The load should be connected to the individual outputs of the EFX power supplies as indicated in FIG. 2-3. Load wires should be as short as possible. Select the heaviest practicable wire gage and twist all loadwire pairs tightly.

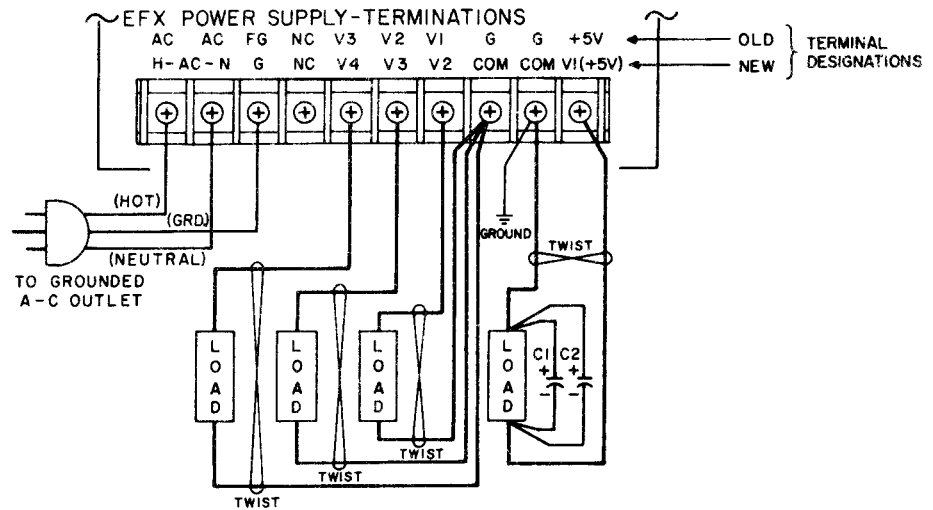

FIG. 2-3 RECOMMENDED LOAD CONNECTIONS

- 2-14 As shown in FIG. 2-3, each load has its own return to the common ground point. The two terminals "COM" are internally connected. If the common ground point must be established elsewhere, then all load return wires should terminate at the new ground point. THE IMPORTANCE OF A SINGLE GROUND POINT IN THE LOAD CIRCUIT CAN NOT BE OVERSTATED. MULTIPLE GROUND POINTS RESULT IN GROUND LOOPS WHICH CAUSE GREATLY INCREASED RIPPLE AND NOISE. For minimum ripple and noise at the load, an additional filter may be required at each load (see FIG. 2-3, 5V output). The filter consists of a pair of low/high frequency bypass capacitors (C1 = 50 $\mu$ F electrolytic, C2 = 0.1 $\mu$ F film-type).