

# INSTRUCTION MANUAL



**KEPCO** An ISO 9001 Company.

**CA-18**

COVER

## ENCLOSURES AND HARDWARE SYSTEMS

**DESCRIPTION.** The Kepco Model CA-18 COVER is designed to provide shielding and protection for the Kepco ERX 240W Series of switching power supplies. These finished steel covers have four (4) mounting threads and are easily installed, using the predrilled, counter-sunk mounting holes on the ERX chassis, as shown in FIG. 1.

### INSTALLATION.

- 1) Slip the cover over the ERX chassis as shown in FIG. 1.
- 2) Place the four (4) mounting screws, contained in the plastic bag delivered with the cover, through the counter-sunk holes in the ERX chassis and hand-tighten the screws.
- 3) Align the cover and tighten the mounting screws.

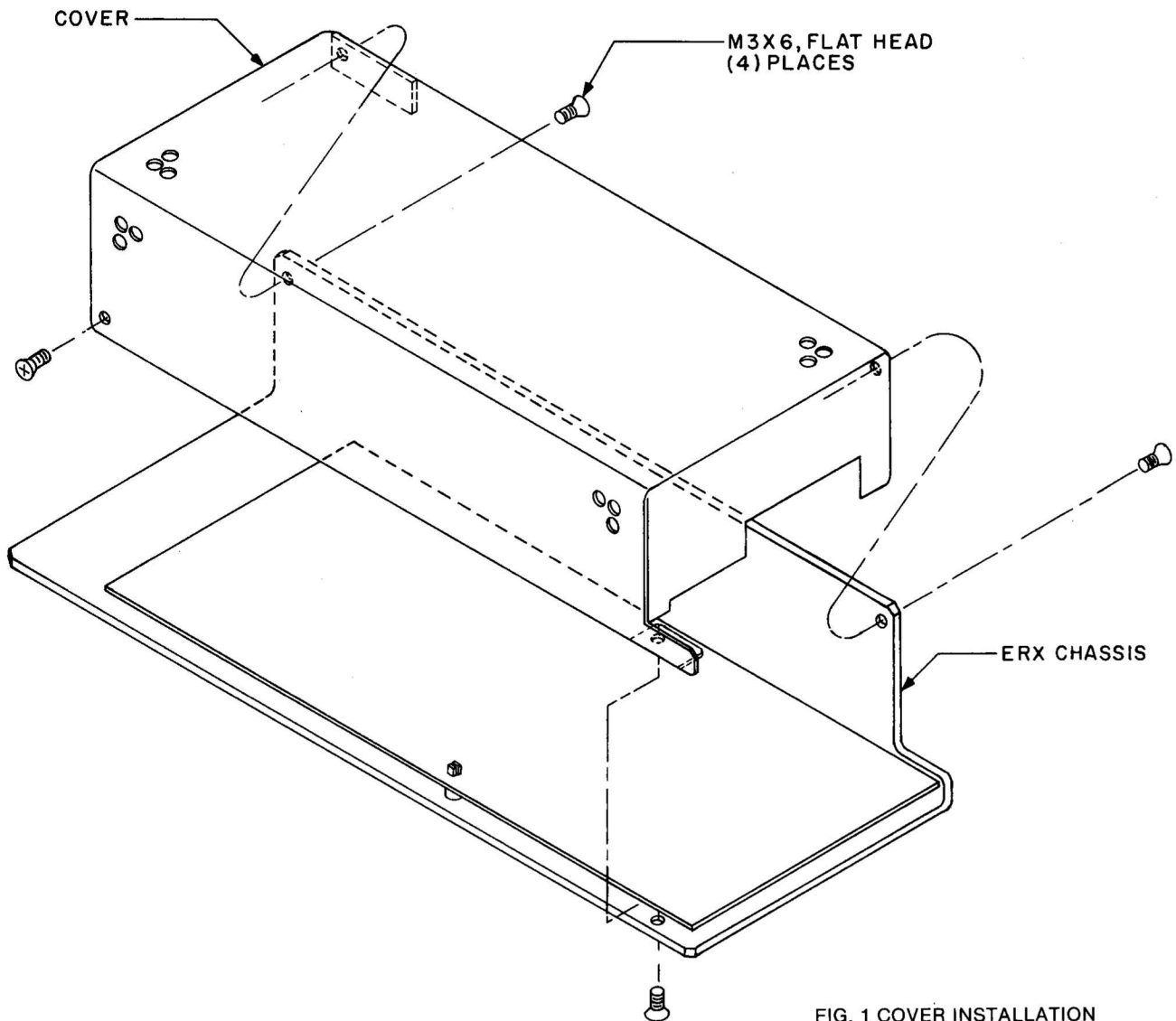
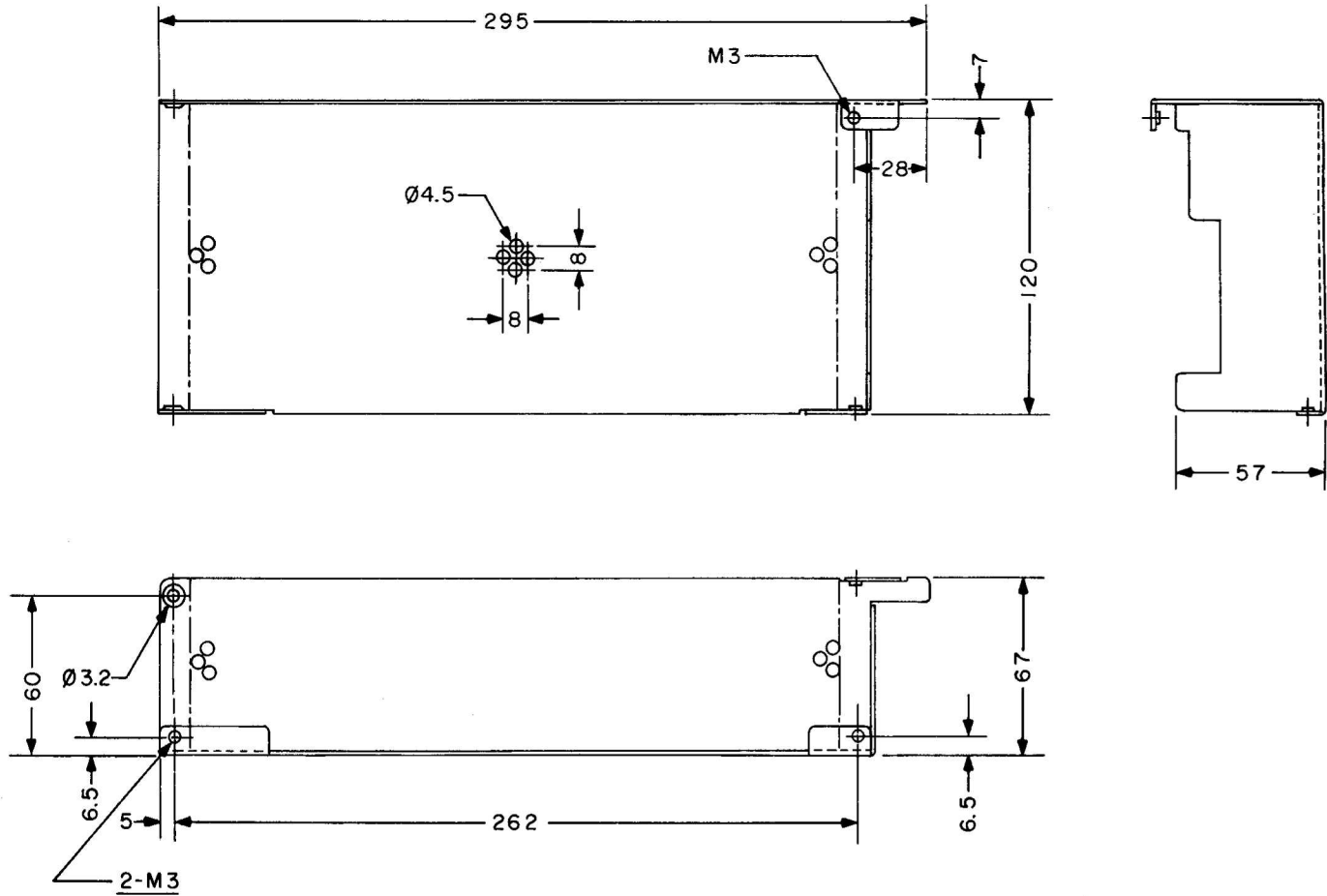

FIG. 1 COVER INSTALLATION



- NOTES:** 1) Mat'l.: CRS-0.8mm, Alternative: Galvanized Steel  
 2) Finish: Cadmium Plated, Chromate wash  
 3) All dimensions are in millimeters  
 4) Tolerances:  $\pm 0.5$  mm mounting holes;  
 $\pm 1$  mm other dimensions

FIG. 2 MECHANICAL OUTLINE DRAWING