



**MODIFICATION OF STANDARD
KEPCO MODEL BOP 20-5MC
KEPCO MODEL BOP 20-5DC**

The Kepco Models BOP 20-5MC and BOP 20-5DC have been modified from standard Kepco Models BOP 20-5M and BOP 20-5D, respectively, to be stable handling capacitive loads up to 10 mF.

INSTRUCTION MANUAL CORRECTIONS:

This modification makes the BOP more suitable for a wide variety of applications such as solar cell/ solar panel testing, piezoelectric device driving/ testing, capacitor testing, capacitive transducer driving/testing and powering industrial or lab-type applications for capacitive or capacitive-resistive loads.

Static specifications representing the unit's accuracy in Voltage mode are identical with the standard BOP models, while the ripple and noise specifications are better (approximately 50% lower) for MC and DC models than standard BOP models.

Specifications listed in Table 1 are for BOP 20-5MC and BOP 20-5DC in Voltage Mode.

TABLE 1. BOP 20-5MC AND BOP 20-5DC SPECIFICATIONS

Bandwidth (DC to f-3dB)		Rise/Fall Time ⁽²⁾	Recovery at Step Load ⁽³⁾
Resistive Load, Nominal	Capacitive Load, 10 μ F ⁽¹⁾		
12.1 kHz	15.5 kHz	42 μ S	45 μ S

NOTES:

- (1) Nonuniformities of the frequency response for the standard 10 μ F load create a larger 3-dB bandwidth than for the resistive load.
- (2) 10% to 90%, with nominal resistive load.
- (3) Load between infinity and nominal resistive load values.

In voltage mode the bandwidth of the BOP 20-5MC and DC models is less than the standard BOP, while the response time is increased. Nonuniformities of the frequency response can be nearly eliminated by reducing the bandwidth in Voltage mode.

Reducing Bandwidth. Bandwidth can be reduced in a predictable manner by increasing the internal compensation capacitance by placing an external capacitor (see Table 2) in parallel with the main compensation capacitor of Assembly A1.

- For older models, identified by the indicator between the two front panel meters labeled REMOTE, the external capacitor is soldered across A1C21 (see Figure 1).
- For newer models, identified by the indicator between the two front panel meters labeled REMOTE (W DIG ON)/OUT ON (W DIG OFF), connect the external capacitor across pins 12 and 14 of the rear programming connector.

TABLE 2. BANDWIDTH CORRECTION

	EXTERNAL CAPACITOR (ACROSS A1C21, SEE FIGURE 1)						
	1 nF	2.2 nF	4.7 nF	15 nF	33 nF	47 nF	100 nF
CORRECTED BANDWIDTH	11.5 kHz	8.5 kHz	5.6 kHz	2.9 kHz	1.4 kHz	1.1 kHz	0.52 kHz

NOTE: Listed bandwidth correction values are for Voltage mode, nominal resistive load.

In Current Mode the dynamic specifications are: 3-dB bandwidth of 2.8kHz and rise/ fall time of 135 μ s.

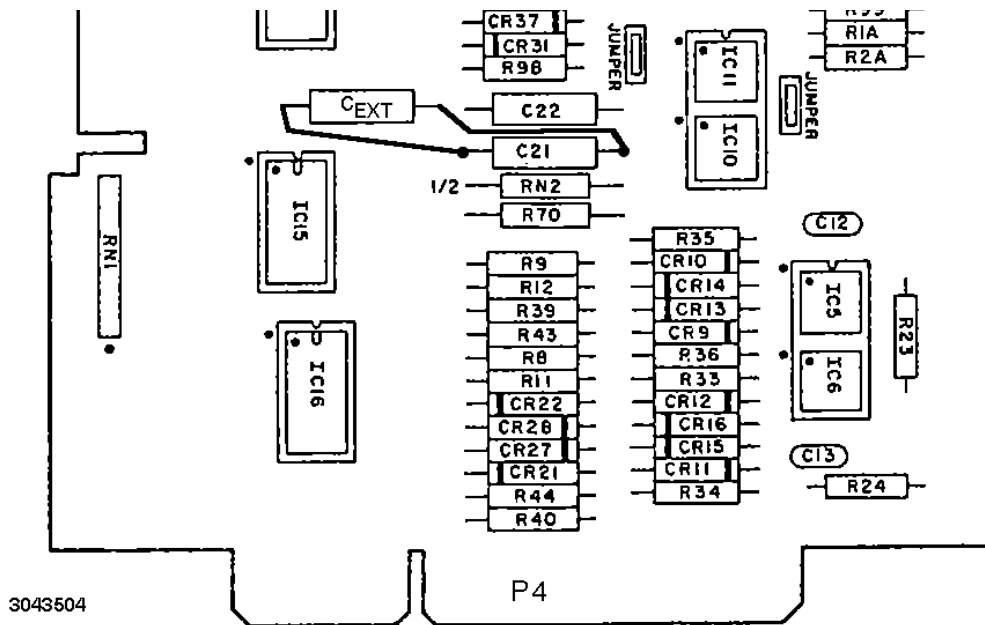

FIGURE 1. ASSEMBLY A1, EXTERNAL BANDWIDTH CORRECTION CAPACITOR LOCATION (OLDER MODELS ONLY)