

# INSTRUCTION SHEET

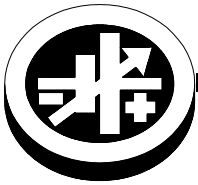

**KEPCO** An ISO 9001 Company.

**MA  
HK100/  
RTW100V**

## MOUNTING ADAPTER MA HK100/RTW100V

**DESCRIPTION.** The Model MA HK100/RTW100V Mounting Adapter includes an adapter plate and mounting screws that allow a 100W RTW power supply to be easily substituted for a vertically-mounted HK100 power supply. Mount the adapter plate to the RTW power supply using the hardware provided (see Figure 1), then install the adapter plate in place of the HK100 power supply using the screws that previously secured the HK100 power supply.

### NOTES:

1. MOUNT ADAPTER PLATE TO RTW POWER SUPPLY AT HOLES "A" USING TWO SCREWS AND RETAINING SPACERS PROVIDED.
2. INSTALL ADAPTER PLATE WITH RTW ATTACHED USING HARDWARE PREVIOUSLY USED TO MOUNT HK POWER SUPPLY (NOT SUPPLIED) AT HOLES "B".
3. MAX PENETRATION OF SCREWS (M4) AT HOLES "B" MUST NOT EXCEED 5MM.

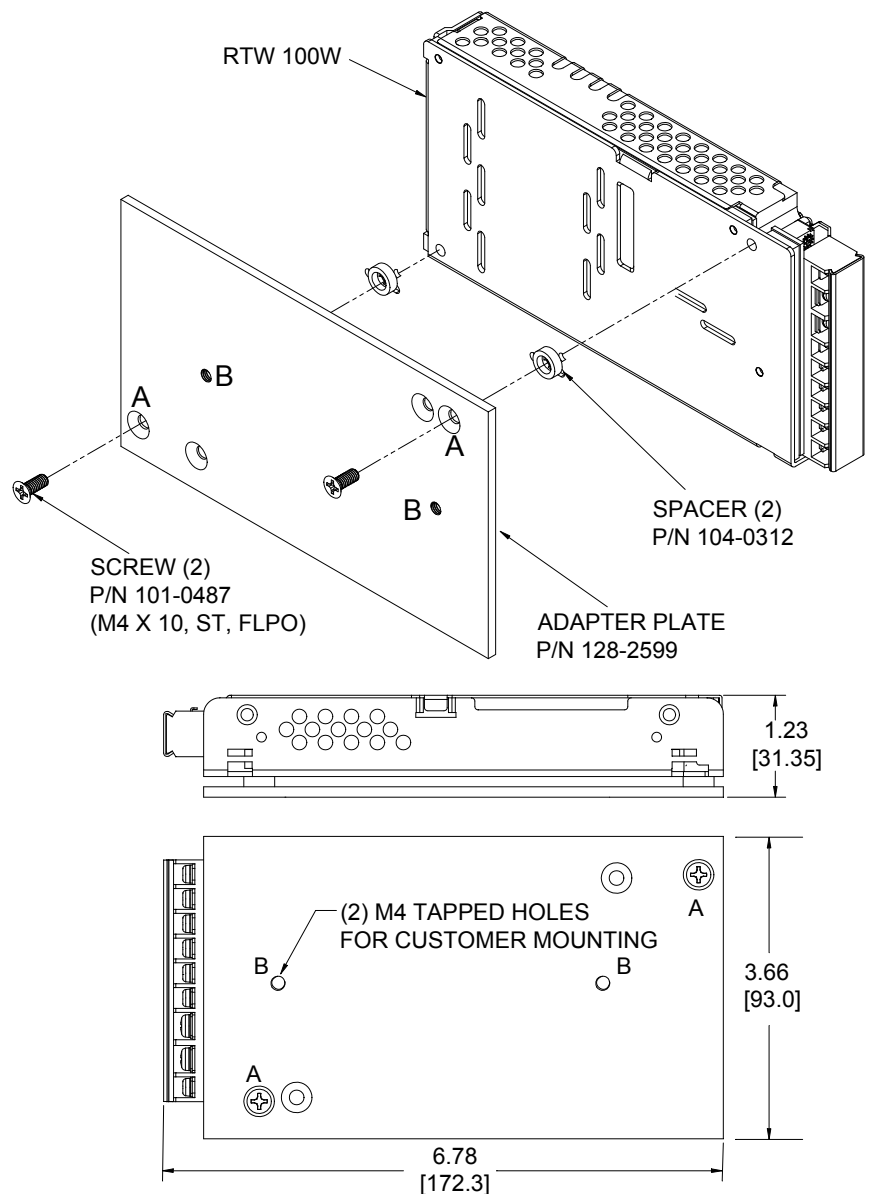

**FIGURE 1. ADAPTER PLATE INSTALLATION**

3044587