

# INSTRUCTION MANUAL



**KEPCO** An ISO 9001 Company.

**BOP 1KW  
-GL, -EL TO  
-MGL, -MEL  
KIT 219-0628**

## BOP 1KW-GL, EL TO MGL, MEL FRONT PANEL RETROFIT KIT

### 1. DESCRIPTION

Kepeco KIT 219-0628 contains a front panel assembly that includes a color display and keypad which is used to upgrade BOP 1KW-GL and -EL models to -MGL and -MEL models, respectively.

### 2. APPLICABILITY

This KIT applies only to models listed in Table 1.

**TABLE 1. APPLICABILITY**

MODEL	KIT PART NUMBER
BOP 10-100GL	KIT 219-628-1G
BOP 10-100EL	KIT 219-628-1E
BOP 20-50GL	KIT 219-628-2G
BOP 20-50EL	KIT 219-628-2E
BOP 36-28GL	KIT 219-628-3G
BOP36-28EL	KIT 219-628-3E
BOP 50-20GL	KIT 219-628-5G
BOP 50-20-EL	KIT 219-628-5E

### 3. INSTALLATION INSTRUCTIONS

#### 3.1 MATERIAL REQUIRED (See Table 2.)

**TABLE 2. MATERIAL REQUIRED**

MATERIAL	LOCATION	QUANTITY
Front Panel Assembly	Provided in this Kit	1
Instruction Manual Kepeco P/N 228-1917	Provided in this Kit	1
Phillips Screw Driver	Not Supplied	N/A

#### 3.2 DISASSEMBLY PROCEDURE

1. Turn power off, disconnect the unit from source power and remove line cord.
2. Remove the two mounting ears from the chassis by removing three screws from each.
3. Remove the top cover of the unit by removing 14 screws as follows: two at top of the front panel, four at each side, (one towards the rear, three at the bottom) and four at the top of the rear panel.
4. Disconnect ribbon cable attached to Distribution board A6A1 (see Figure 1) going to Front End Control board A4A3 connector J1.

5. Disconnect ribbon cable attached to Distribution board A6A1 going to Digital board A1J2.
6. Disconnect one 4-pin and one 6-pin connector (J12, J15, Figure 1), and one 5-pin connector (J14, Figure 1) wired with twisted pairs from Distribution board A6A1. Pull on the twisted pair where it enters the connector; if necessary, a screwdriver can be used to apply enough pressure to front panel to slightly increase separation between front panel and Distribution board A6A1, enough for the connectors to be removed.

**CAUTION: Failure to pull the fan connector straight back can damage the connector.**

7. Remove fan connector (J10, Figure 1) from Distribution board A6A1 by pulling connector straight back.

**CAUTION: Removing the outer screws first can result in damage to the front panel.**

8. At the bottom of the chassis, first remove the two inner screws, then the two outer screws securing front panel to chassis and separate front panel and Distribution board A6A1 from the chassis.
9. Carefully pull the front panel straight back from the chassis to disengage the circuit breaker pins and separate the front panel from the chassis.
10. Remove the circuit breaker from the front panel by pressing the circuit breaker tabs.

### 3.3 FRONT PANEL REPLACEMENT (SEE FIGURE 1)

1. Unwrap new front panel supplied in this kit.
2. Use the wrapping material to wrap the front panel removed in PAR. 3.2 and ship back to Kepco for credit.
3. Insert circuit breaker removed in PAR. 3.2 into new front panel.
4. Carefully line up pins of circuit breaker removed in PAR. 3.2 with corresponding connectors on new front panel and carefully mate front panel and chassis. Press the PCB onto the circuit breaker.

### 3.4 REASSEMBLY

**CAUTION: Installing the inner screws first can result in damage to the front panel.**

1. Attach front panel with Distribution board A6A1 to the chassis first using two outer screws at the bottom of the chassis, then two inner screws.
2. Connect one 4-pin, one 6-pin connector, and one 5-pin connector attached to twisted pairs to connectors J12, J15 and J14, respectively on Distribution board A6A1 (see Figure 1). Holding the wires, line up the pins on an angle, then push until straight and press into place; if necessary a screwdriver can be used to apply enough pressure to front panel to slightly increase separation between front panel and Distribution board A6A1, enough for the connectors to be inserted.
3. Attach the fan connector (J10, Figure 1) by inserting the connector straight into the mating socket.
4. Connect ribbon cable from Distribution board A6A1 to Digital board connector A1J2.
5. Connect ribbon cable from A4A3 module to Distribution board A6A1 connector J11.
6. Attach the cover to the chassis using 14 screws. Figure 2 shows the unit after reassembly.
7. Attach the two mounting ears to the chassis using three screws for each.
8. Install the power cord, connect the unit to source power, turn on power supply

## 4. INSTRUCTION MANUAL CHANGES

Refer to Quick Start Guide 228-1692 and Operator's Manual P/N 243-1027 for complete instructions for the updated unit. These manuals can be downloaded from the Kepco web site at

[www.kepcopower.com/support/opmanIs.htm#bop-1k-mg](http://www.kepcopower.com/support/opmanIs.htm#bop-1k-mg)

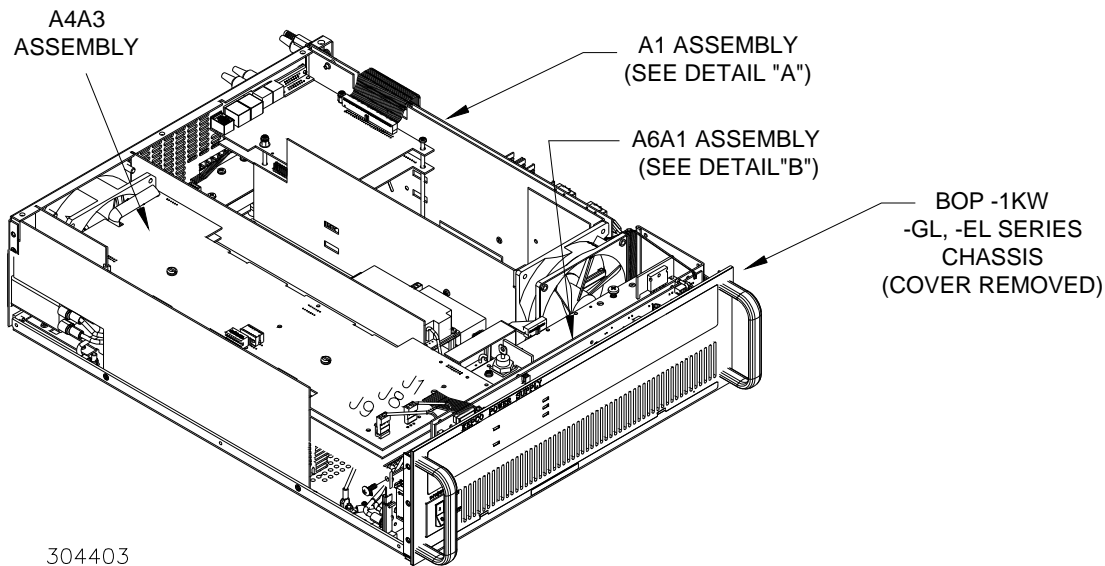
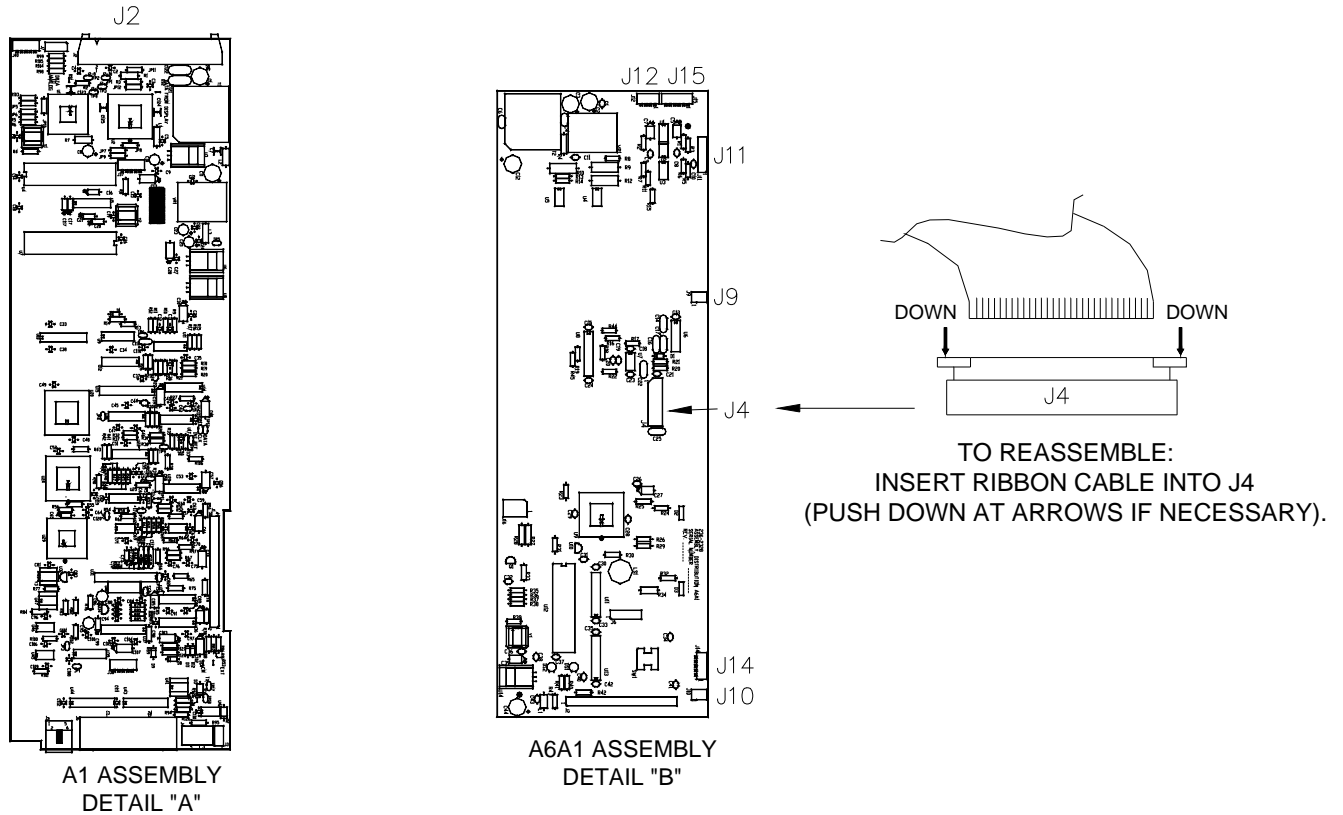

**FIGURE 1. ASSEMBLIES A1, A4A3 AND A6A1 COMPONENT LOCATIONS**

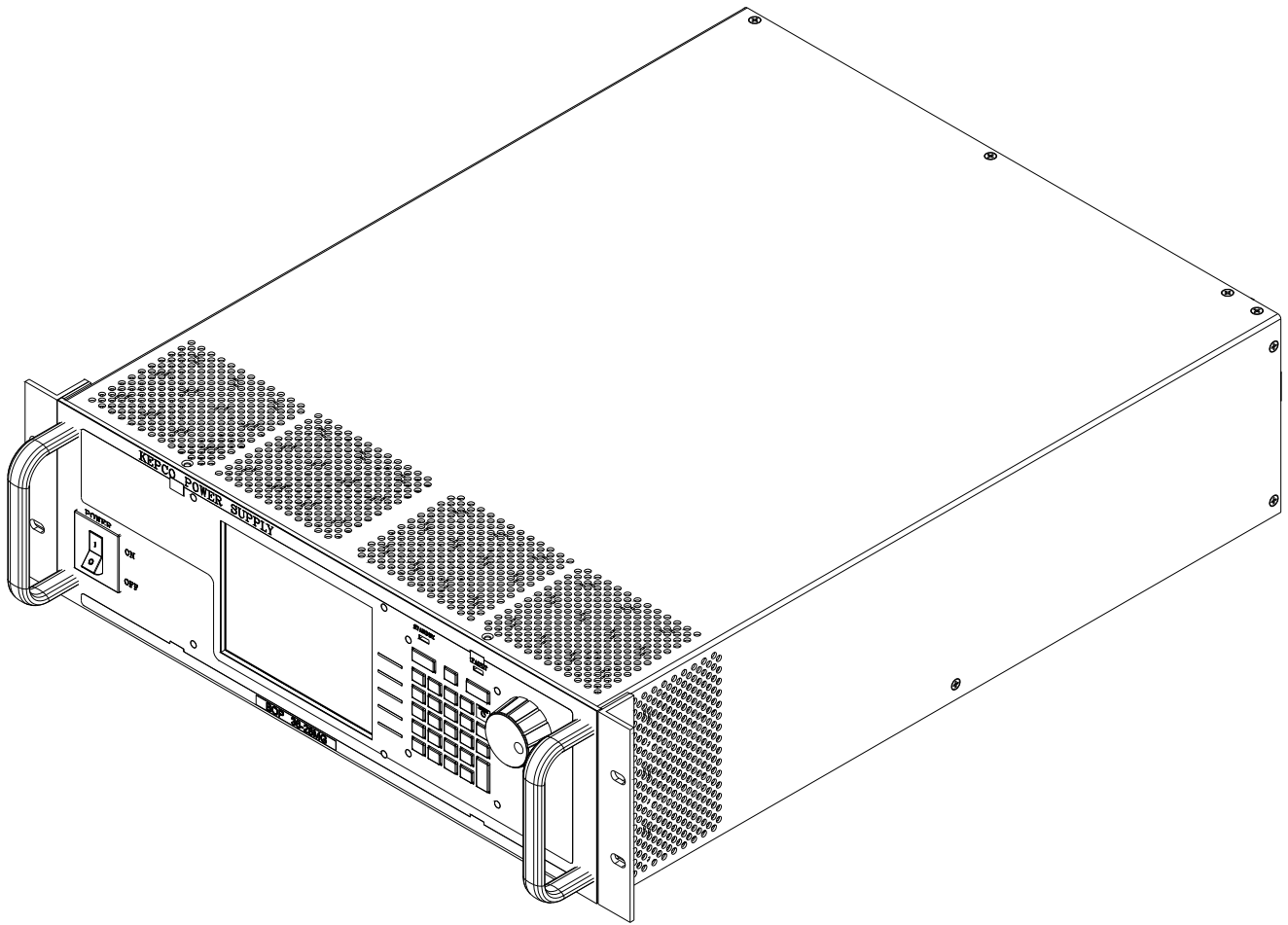

3044404

**FIGURE 2. BOP 1KW -MGL, -MEL AFTER RETROFIT COMPLETE**