

QUICK START GUIDE

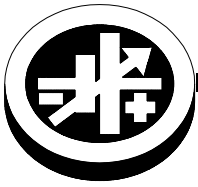

KEPCO An ISO 9001 Company.

ATE
(DM) CE

VOLTAGE/CURRENT STABILIZED POWER SUPPLY

I — INTRODUCTION

1.1. SCOPE OF MANUAL. This Quick Start Guide covers simple installation and local operation of the Kepco ATE Series of 50W, 100W, 250W, 500W and 1000W voltage and current stabilized ATE d-c power supplies with DM suffix (digital meters). Full specifications, features and instructions are found in the associated Operator Manuals that can be downloaded free from the Kepco web site at:

www.kepcopower.com/support/opmanls.htm#ate

1.2. DESCRIPTION.

The Kepco ATE with programmable overvoltage protector is a precision stabilized power supply which can deliver either stabilized output voltage or current. The prevailing operating mode is indicated by LED mode indicators at the front panel (Figure 1). Operating mode crossover is automatic and may be monitored remotely by means of a flag signal, available at the rear programming connector. The power supply features "full range" output control by means of 10-turn, high resolution front panel potentiometers for output voltage and output current. A pair of front panel meters constantly monitor the output voltage and output current.

The ATE power supply features user-selectable "slow" or "fast" operating modes. Slow mode operation is recommended for applications demanding a voltage source with low ripple. Fast mode operation is best if the output voltage must change rapidly, either in response to an external programming signal, or if the ATE is used as a current stabilizer which must react quickly to changes in load resistance.

The ATE power supply is delivered for "slow mode" operation. Refer to Operator Manual (see PAR. 1.1) for converting the ATE power supply to "fast mode" operation.

An overvoltage protection circuit, continuously adjustable as well as remotely programmable, is a built-in feature. The trigger point of the overvoltage protector may be set (or checked) under actual operating conditions by the front panel-accessible setup controls.

Units are shipped for 115V a-c operation (105V to 125V a-c), 50 to 65Hz. For operation at 104V a-c, 208V a-c or 230V a-c refer to the full Operator manual (PAR 1.1).

1.3. OPTIONS. Models with a DM suffix include digital meters. Suffix L indicates models with front panel knobs that have been replaced by locking-type screwdriver-adjustable front panel controls.

1.4. EQUIPMENT SUPPLIED.

- **ATE 1/4 Rack only:** PC 13 connector (PC 13 is an unwired PC 12 that has been pre-wired for front panel control of ATE 1/4 Rack models which **MUST be installed at rear panel to enable local operation**).
- **ATE 1/2, 3/4, Full Rack only:** PC 14 connector (PC 14 is an unwired PC 12 that has been pre-wired for front panel control of ATE 1/2, 3/4 and Full Rack models which **MUST be installed at rear panel to enable local operation**).
- 115V a-c Line Cord

1.5. ACCESSORIES (NOT SUPPLIED)

See <http://www.kepcopower.com/atebuy.htm> to order accessories.

- Unwired PC 12 programming connector(s)
- Rack adapter RA 24, RA 32 or RA 37 to mount rack unit(s) in 19-inch rack
- Slides for Rack Adapter or Full Rack models
- Cable KIT 219-0609 Master/Slave Parallel Configuration of identical ATE 1/2-rack, 3/4-rack or full-rack models
- Barrier Strip terminal link P/N 172-0306

**1/4 Rack
50W, 100W**

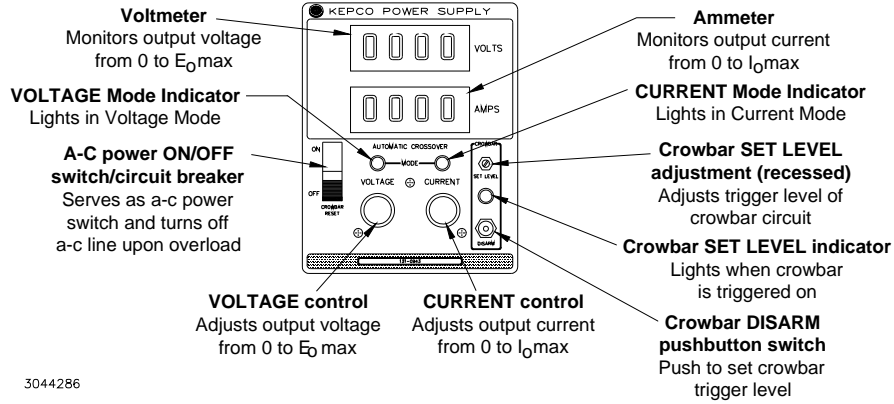

**1/2 Rack
250W**

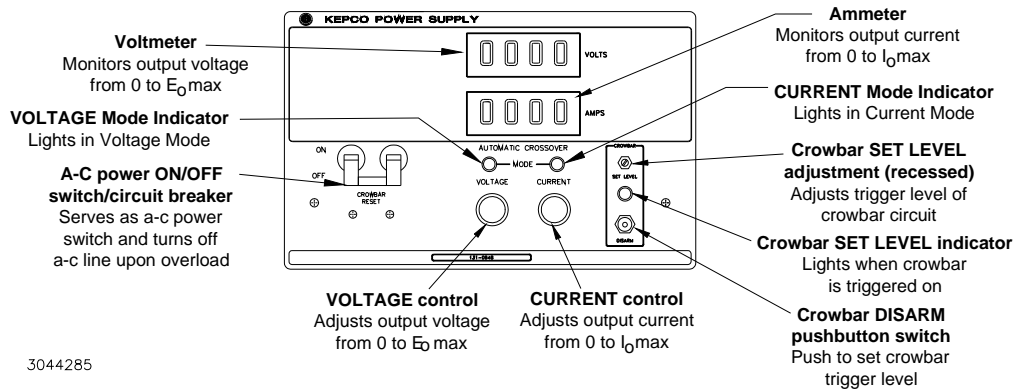

**3/4 Rack
500W**

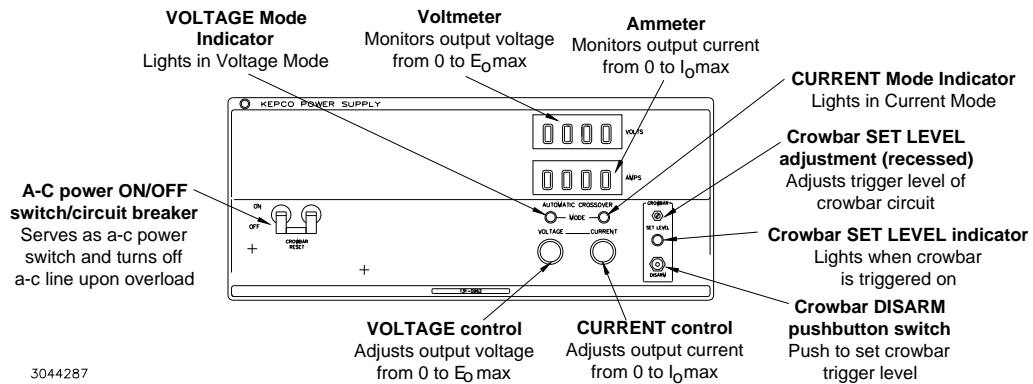

**Full Rack
1000W**

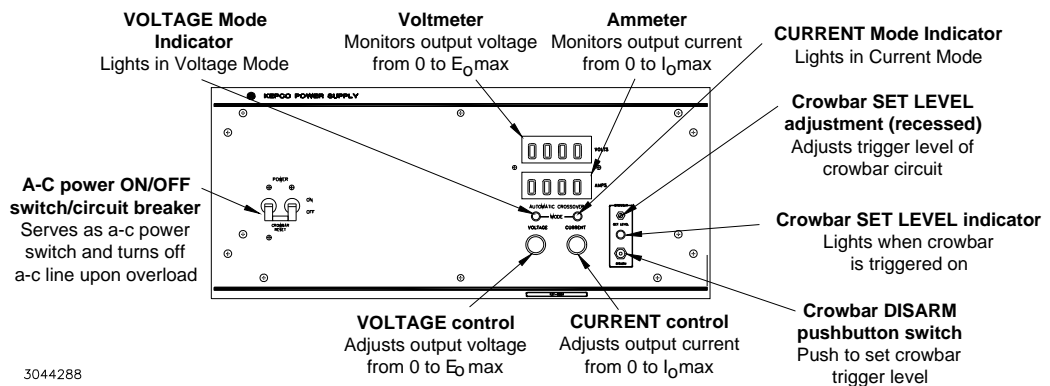

FIGURE 1. FRONT PANEL CONTROLS AND INDICATORS

II — SAFETY.

Exercise care in making all connections to and from the ATE terminals.



WARNINGS

1. Remove a-c power from the ATE before making any connections.
2. Wires and/or cables, connected from the ATE terminals to external components or programming devices must

be properly insulated and securely terminated on both sides to make accidental touch impossible.

3. The ATE chassis and cover must be safety-grounded to a reliable a-c source ground. A safety-ground may be established by using a grounded a-c power outlet or, if the latter is not available, by means of a separate wire, from the provided GROUND terminal (at the rear barrier strip) to a reliable a-c source ground point.

III — INSTALLATION

3.1. UNPACKING. The power supply has been thoroughly inspected and tested prior to packing and is ready for operation. After careful unpacking, inspect for shipping damage before attempting to operate. Perform the Preliminary Checkout (PAR. 3.2). If any indication of damage is found, file an immediate claim with the responsible transport service

3.2. PRELIMINARY CHECKOUT. A simple operating check after unpacking and before permanent installation, is advisable to ascertain whether the ATE has suffered damage in shipment.

1. Install Programming Connector (supplied) at rear panel.
This is required for local control of the unit.
2. Refer to Safety instructions (see Section II) and connect unit to 115V a-c source; refer to Operator manual (see PAR 1.1) for different source voltage.
3. Set the ATE front panel controls (Figure 1) as follows:
 - a. Turn CURRENT control fully clockwise.
 - b. Turn VOLTAGE control fully counterclockwise.
 - c. Set a-c power ON/OFF switch/circuit breaker to ON.
 - d. Verify that Voltage MODE indicator is on.
4. Slowly turn VOLTAGE control clockwise and observe a gradual increase of output voltage. Verify that the VOLTMETER reads full scale when control is fully clockwise.
5. Check the overvoltage “crowbar” circuit as follows:

- a. Turn the VOLTAGE control to about one-half of its range.
 - b. Depress the DISARM pushbutton and turn the (recessed) LEVEL control slowly counterclockwise until the CROWBAR indicator lights.
 - c. Turn VOLTAGE control slightly counterclockwise and release DISARM button. Now when the VOLTAGE control is increased to the overvoltage setpoint, the input circuit breaker trips off.
 - d. To set overvoltage to a different value repeating steps a, b, and c, except at step a set the VOLTAGE control to the desired overvoltage setting.
 - e. Turn A-C POWER switch/circuit breaker to OFF.
6. Place a short circuit across the ATE output terminals. Turn CURRENT control counterclockwise. Turn the ATE power to ON. THE CURRENT MODE indicator should now be on. Slowly turn CURRENT control clockwise and observe the gradual increase in output current. Verify that the AMMETER reads full scale when the control is fully clockwise.
 7. Set A-C POWER circuit breaker/switch OFF. Remove the short circuit from the output terminals. This concludes the preliminary check-out of the ATE.

3.3. INSTALLING THE POWER SUPPLY.

ATE models are shipped with four plastic feet installed for benchtop operation. The feet must be removed for rack mounting. Kepco's RA 24, RA 32 or RA 37 Rack Adapters can be used to install these models in a standard 19-inch rack (installation instructions supplied with rack adapter).

3.4. CONNECTIONS. Connections are made using the rear panel terminations (see Figure 3).

3.4.1. LOAD CONNECTION, GENERAL. Connect the load between -OUT and +OUT output power terminals at the rear panel (see Figure 3. *Sense connections are required, either local or remote, must be used; otherwise the unit will not operate.*

See PAR. 3.4.2 for local sensing, see PAR. 3.4.3 for remote sensing. Refer to the full Operator Manual (see PAR. 1.1) if step changes in the load are expected if, for example, the load is rapidly changing in value, or if the power supply is programmed with step functions (square wave, pulse, etc.) and maximum dynamic performance is expected. If so, set the unit to "fast" mode by referring to the full Operator Manual (see PAR. 1.1). Note that ripple in "fast" mode will be higher than for the default "slow" mode.

Terminals on the programming connector at the rear panel and on the barrier strip (TB201) permit maximum flexibility in power supply/load interface techniques. The programming connector supplied has been pre-wired with jumpers configured for front panel (local) control of output voltage, output current and VP crowbar level with the power supply operating in the "slow" mode.

The rear programming connector **MUST be installed for power supply to operate.**

To configure the programming connector to allow remote programming of the power supply, "fast mode," or to use a user-configured unwired PC 12 programming connector (or to modify the programming connector supplied), refer to the full Operator Manual (see PAR. 1.1). If the programming connector jumper configuration has been altered, make sure that all wires are properly soldered: **loose connections at the programming connector will cause the power supply to malfunction.**

3.4.2. LOAD CONNECTION, LOCAL SENSING. Figure 2 illustrates load connection using local sensing. Refer to the full Operator Manual for load wire selection guidelines. The output power leads should be twisted or tied together to reduce EMI.

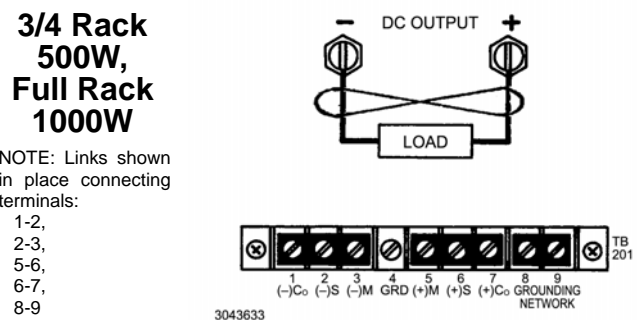
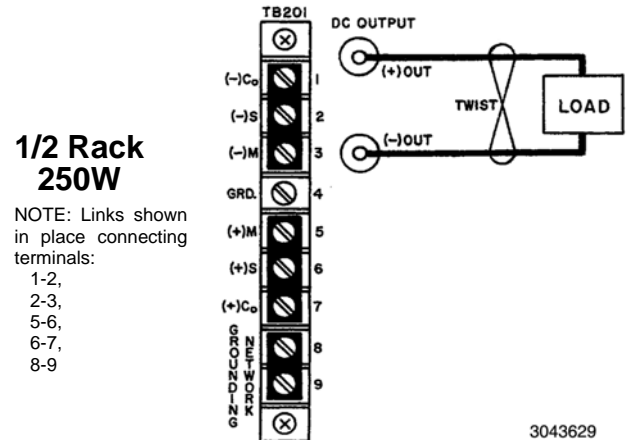
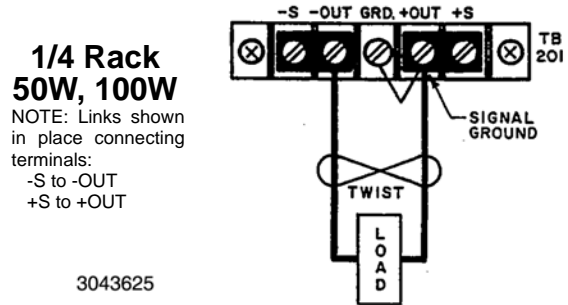
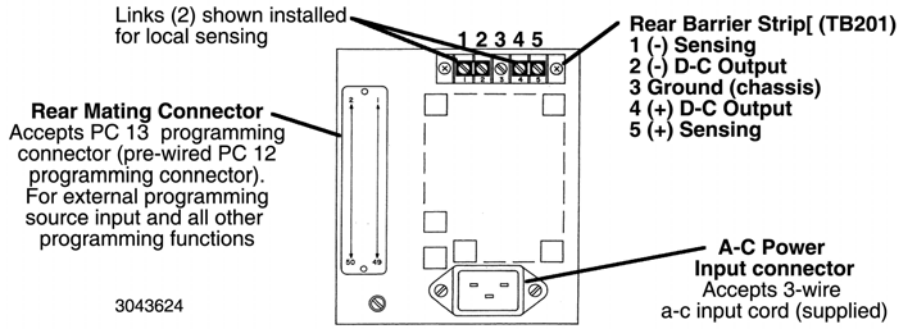
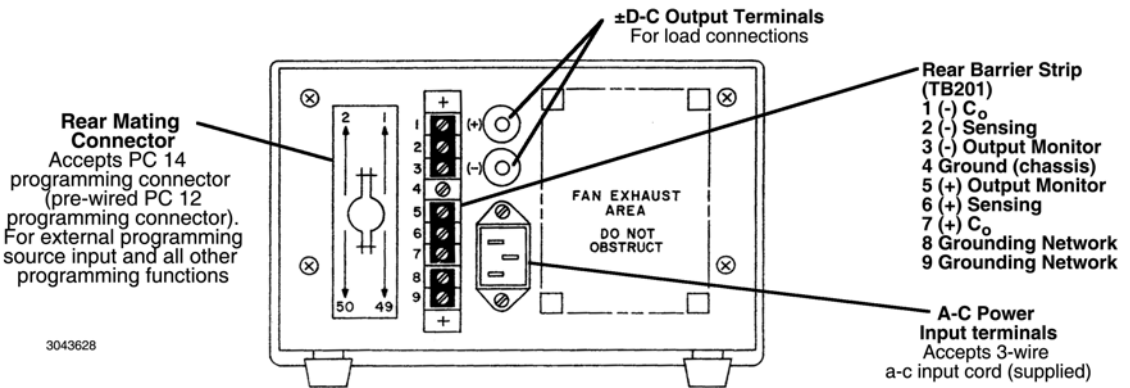

FIGURE 2. LOCAL SENSING

**1/4 Rack
50W, 100W**



**1/2 Rack
250W**



**3/4 Rack
500W**

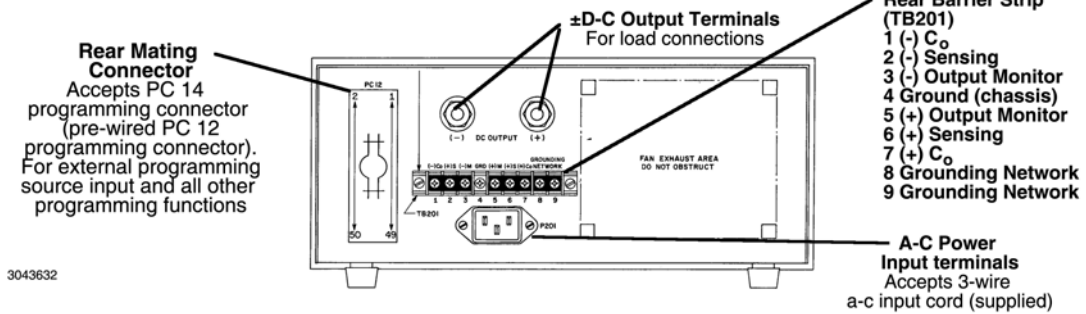

**Full Rack
1000W**

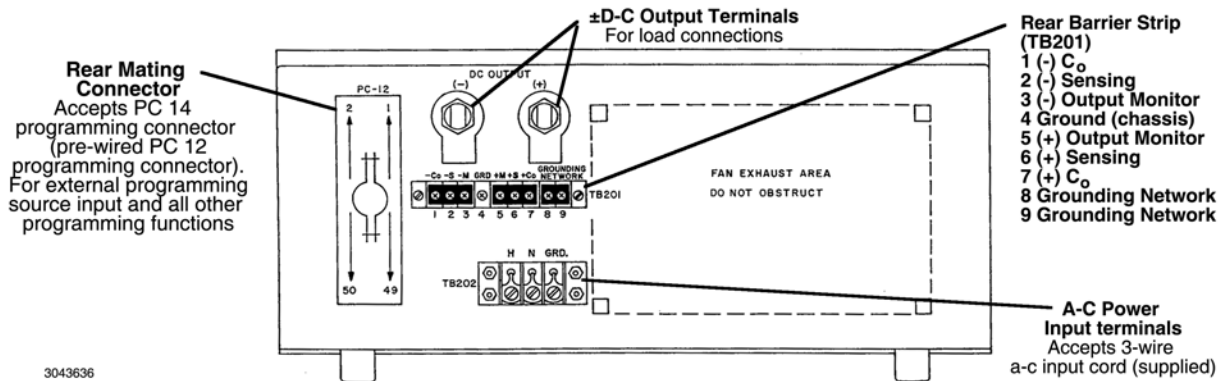

FIGURE 3. REAR PANEL TERMINATIONS

3.4.3. LOAD CONNECTION, REMOTE SENSING. To avoid excessive output effects at remote loads, remote error sensing must be used (Kelvin connection). A pair of wires (twisted to reduce EMI) connected from the sensing terminals directly to the load will compensate for load wire voltage drops up to 0.5 volt per wire (refer to Figure 3. 3-4). Observe polarities: the negative sensing wire must go to the negative load wire, and the positive sensing wire goes to the positive load wire.

For large capacitive loads with long wire runs, refer to the full Operator Manual for techniques used to reduce low frequency oscillations observed at the load.

3.4.4. INPUT A-C CONNECTIONS. Install the line cord (supplied) at the rear panel and connect to 115V a-c, 60Hz (105V to 125V a-c, 50 to 65Hz) mains. Refer to the full Operator Manual for operation at 104V a-c, 208V a-c or 230V a-c (see PAR. 1.1).A-C Safety Ground.

The power supply is equipped with a 3-wire safety line cord and polarized plug. The third (green) wire in the line cord is connected to the chassis and the case of the unit. If a 2-terminal receptacle in combination with an adapter is used, it is imperative that the chassis of the power supply be returned to a-c ground with a separate lead. A grounding terminal is provided (at the rear barrier strip) for this purpose.

3.4.5. ISOLATION FROM GROUND. The d-c output is isolated from the a-c source and from any direct connection to chassis or ground. The maximum output voltage that can be supported between either output terminals and ground or chassis is 500V (d-c or peak), plus the maximum output voltage of the power supply. Either side of the output may be grounded.

The common mode current (leakage from output to ground) is less than 5 μ A (rms) or 50 μ A (p-p) at 115V a-c power input, 60 Hz. To avoid common mode current from affecting the ATE output, the system (including the programming device, if used, load, and ATE) must have a single connection to ground (earth ground). The d-c ground wire must be rated for the nominal output current of the ATE (e.g, for ATE 6-10M, use rating of 10A).

Multiple signal grounds in the system may cause "ground-loop" problems, since noise signals develop across the impedances between the multiple ground points. The exact physical location of the "best" single ground point must be carefully selected for minimum ripple/noise output.

NOTE: A resistor/capacitor network is connected from the negative output terminal to the metal chassis of the power

supply. If the internal signal ground is not desired, the connection to the chassis can be opened (see full Operator Manual).

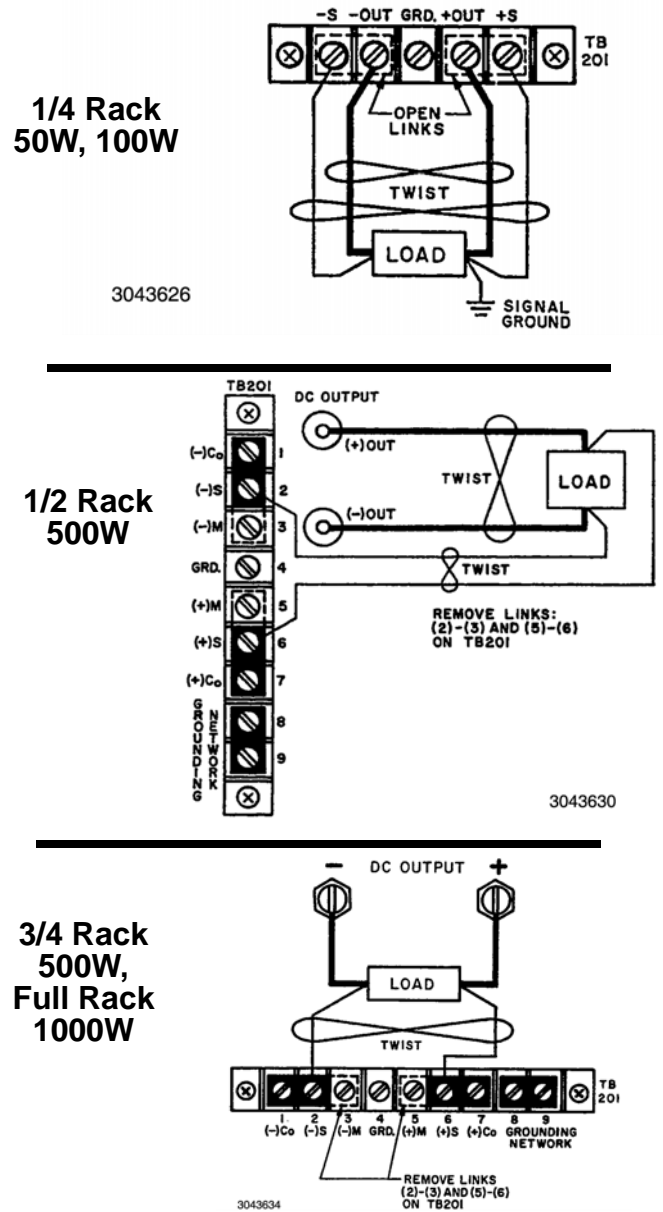

FIGURE 4. REMOTE SENSING

3.5. COOLING. The components in the ATE power supply rely on forced air cooling. SIDE PANEL OPENINGS AND THE TOP OF THE CASE MUST BE KEPT CLEAR FROM ALL OBSTRUCTIONS TO ENSURE AIR CIRCULATION. Periodic cleaning of the interior of the power supply is recommended. If the ATE is rack-mounted or installed into confined spaces, care must be taken that the ambient temperature (the temperature immediately surrounding the power supply) does not rise above 65°C (~149°F).

IV — OPERATION

Turn the unit on using the front panel a-c power ON/OFF switch/circuit breaker (see Figure 1). **CAUTION: DO NOT repeatedly toggle the ON/OFF switch as this may cause unit to fault.** If actuator does not lock when released, wait a few seconds before trying again. The circuit breaker is “trip-free;” if overload exists, contacts cannot be held closed by actuator.

NOTE: Rear programming connector (supplied) must be installed to enable local control of the unit.

The ATE power supply is delivered for “slow mode” operation (see PAR. 1.2). Refer to full Operator Manual (see PAR. 1.1) for converting the ATE power supply to “fast mode” operation.

4.1. VOLTAGE MODE OPERATION.

1. With a-c power OFF, connect the load to the output terminals of the ATE Power Supply in accordance with safety (Section II), and grounding guidelines (PAR. 3.4). Always monitor the front panel meters while adjusting output voltage/current.
2. Turn VOLTAGE control completely counterclockwise and CURRENT control completely clockwise.
3. Set a-c power ON/OFF switch/circuit breaker to ON. Verify that voltage MODE indicator is on.
4. Observe front panel VOLTMETER and adjust VOLTAGE control to the desired output voltage level. Set a-c power ON/OFF switch/circuit breaker to OFF.
5. Turn CURRENT control completely counterclockwise.
6. Apply a short circuit across the output terminals of the ATE Power Supply.
7. Set a-c power ON/OFF switch/circuit breaker to ON. Verify that current MODE indicator is on.
8. Observe front panel CURRENT meter and adjust CURRENT control to the required load current value, plus 2% of the rated current. In voltage mode operation, this setting will determine the voltage/current “crossover” point.
9. Set a-c power ON/OFF switch/circuit breaker to OFF.
10. Remove the short circuit from the output terminals. The power supply is now ready for operation.

4.2. CURRENT MODE OPERATION.

1. **Before** connecting the load to the power supply output terminals, set a-c power ON/OFF switch/circuit breaker to ON. Verify that VOLTAGE MODE indicator is on.
2. Observe the front panel VOLTMETER and adjust the VOLTAGE control to the required compliance (output voltage) level.
3. Set a-c power ON/OFF switch/circuit breaker to OFF, and connect a short circuit to the output terminals of the ATE.
4. Set a-c power ON/OFF switch/circuit breaker to ON.
5. Observe the front panel CURRENT meter and adjust CURRENT control to the desired value. Verify that CURRENT MODE indicator goes on to indicate that the power supply is in the current mode of operation.
6. Set a-c power ON/OFF switch/circuit breaker to OFF.
7. Remove the short circuit, then connect the load to the output terminals of the ATE Power Supply in accordance with safety (Section II), and grounding guidelines (PAR. 3.4).
8. Set a-c power ON/OFF switch/circuit breaker to ON. If the ATE does not enter the current mode (as indicated by the front panel CURRENT MODE indicator), the load resistance (R_L) is too high. Either 1) decrease R_L , 2) increase VOLTAGE control setting, or 3) decrease CURRENT control setting. The ATE is now ready for operation.

4.3. OVERVOLTAGE CROWBAR, SETUP AND CHECK The overvoltage crowbar circuit protects the load from momentary or long-term overvoltages. The crowbar SCR conducts across the power supply output, and the a-c power ON/OFF switch/circuit breaker trips if such overvoltages occur. The setting of the front panel LEVEL control determines the threshold between the actual operating voltage of the power supply and the level at which the crowbar circuit will be activated.

The LEVEL control can be set from 3 volts to 110% of the rated output voltage. The LEVEL control may be adjusted very close to the operating voltage (minimum threshold = 2% of rated output voltage or 0.5 volt, whichever is greater). The operation of the crowbar circuit can be checked without actually triggering the crowbar.

1. With the load disconnected from the power supply turn SET LEVEL control fully clockwise and set a-c power ON/OFF switch/circuit breaker to ON.
2. Observe front panel VOLTMETER and set VOLTAGE control to desired value at which crowbar must trigger (NOT to the actual operating voltage).
3. Depress the DISARM button (and keep it depressed) while turning the crowbar SET LEVEL control counterclockwise, until the SET LEVEL indicator goes on (simulated crowbar action).
4. Turn VOLTAGE control slightly counterclockwise to the actual operating voltage and release the DISARM button. NOTE: This adjustment establishes the threshold i.e., the difference voltage between the output voltage and the voltage at which the power supply will "crowbar." For minimum false triggering use the largest threshold your load can tolerate.
5. To check the adjusted crowbar trigger level, depress DISARM push button and turn VOLTAGE control clockwise. Observe front panel VOLTMETER and note the voltage at which the crowbar SET LEVEL indicator goes on. Correct SET LEVEL adjustment as described above if necessary. Readjustment of the SET LEVEL control may be required after load and power supply have reached thermal equilibrium.

NOTE: If an exact crowbar point at a remote load must be established, remote error sensing, must be used (see PAR 3.4).

6. Reduce power supply output voltage to its operating value.

4.4. ADDITIONAL FEATURES. The following features of the ATE power supply are covered in the full Operator manual (see PAR. 1.1).

- Remote Programming of the Voltage Control Channel
- Remote Programming of the Current Control Channel
- Remote Programming of Crowbar Level
- Automatic Tracking of Crowbar Level
- Use of EXT Current Comparison Amplifier
- Multiple System Control
- Series/Parallel Operation
- Use of Uncommitted Amplifiers and Isolated Flag Signals