

QUICK START GUIDE



KEPCO An ISO 9001 Company.

BOP
2X-D SERIES



BIPOLAR 2X-D SERIES DUAL CHANNEL OPERATIONAL POWER SUPPLY

I — INTRODUCTION

1.1. SCOPE OF MANUAL. This Quick Start Guide covers simple installation and local operation of the Kepco BOP 2X-D Series Dual Channel Bipolar Operational Power Supply. Full specifications, features and instructions are found in the BOP 2X-D Series Operator Manual that can be downloaded free from the Kepco web site at:

www.kepcopower.com/support/opman1s.htm#bop-op

1.2. DESCRIPTION.

Kepco's Series BOP 2X-D dual-channel BOP models are 200W and 400W power supplies. Each channel is a separate power supply, completely isolated, independent and functionally identical. The 200W units have two 100W channels and the 400W units have two 200W channels. The channels are completely isolated, but share two digital front panel meters (without affecting isolation) which display output voltage and current for the channel selected by the front panel Channel select switch. A single power cord powers both channels; separate on-off circuit breakers turn each unit on/off separately.

Each BOP 2X-D channel is a linear stabilizer with two bipolar control loops (voltage or current mode), selectable and individually controllable by remote signals applied to the PC 15 programming connector at the rear panel. These two principal control loops are each protected by bipolar limit circuits. The positive and negative current or voltage limit points can be remotely programmed simultaneously or individually. Automatic crossover between each principal control loop and the limit loops is provided. Only one principle loop (voltage or current) can control the output at any one time.

The channel can operate automatically in all four voltage-current quadrants; it can act as either a source (output voltage is the same polarity as output current) or a sink (output voltage is opposite that of output current). An example is shown in Figure 1 where the BOP channel is programmed to deliver a sine wave output and the load produces a phase shift between the output voltage and current. See BOP 2X-D Series Operator Manual (PAR. 1.1) for limits on long-term operation in sink mode.

Remote On-Off Feature. A remote on-off feature provides isolated remote on-off control of the output; an associated

flag signal is configured at the PC 15 programming connector.

Units are shipped for 115V a-c operation (105V to 125V a-c), 57 to 63Hz. For operation at 104V a-c, 208V a-c or 230V a-c refer to the full Operator Manual (PAR 1.1).

1.3. OPTIONS. Models with a D suffix include digital meters. Models optimized to operate in current mode with large inductive loads are identified by suffix L. Models optimized to operate in voltage mode with large capacitive loads are identified by suffix C.

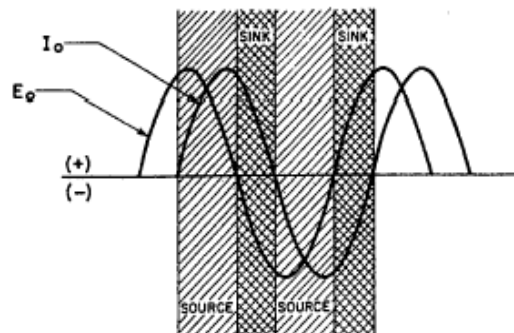

FIGURE 1. SINK OPERATION PRODUCED BY LOAD PHASE SHIFT

1.4. EQUIPMENT SUPPLIED.

- PC 15 programming connector. This programming connector **MUST** be adapted for the desired application (see PAR. 4.1 and 4.2) and **MUST be** installed at the rear panel to enable operation.
- 115V a-c Line Cord

1.5. ACCESSORIES (NOT SUPPLIED)

- Slides

II — SAFETY.

Exercise care in making all connections to and from the BOP terminals.



WARNINGS

1. Remove a-c power from the BOP 2X-D before making any connections.
2. Wires and/or cables, connected from the BOP terminals to external components or programming devices must

be properly insulated and securely terminated on both sides to make accidental touch impossible.

3. The BOP 2X-D chassis and cover must be safety-grounded to a reliable a-c source ground. A safety-ground may be established by using a grounded a-c power outlet or, if the latter is not available, by means of a separate wire, from the provided GND terminal of the rear panel terminal block to a reliable a-c source ground point.

III — INSTALLATION

3.1. UNPACKING. The power supply has been thoroughly inspected and tested prior to packing and is ready for operation. After careful unpacking, inspect for shipping damage before attempting to operate. Perform the Preliminary Checkout (PAR. 3.2). If any indication of damage is found, file an immediate claim with the responsible transport service

3.2. PRELIMINARY CHECKOUT. A simple operating check after unpacking and before permanent installation, is advisable to ascertain whether the BOP 2X-D has suffered damage in shipment.

1. Modify the PC15 (supplied) as described for voltage control (see PAR. 4.1, step 1) and install at rear panel. This is required for local control of the unit.
2. Set the CHANNEL 1 - CHANNEL 2 selector switch to the CHANNEL 1.
3. Refer to Safety instructions (see Section II) and connect unit to 115V a-c source; see Operator Manual (PAR 1.1) for different source voltage.
4. Set the a-c POWER switch for channel under test to ON.
5. Adjust the external programming voltage between +10V and -10V while observing the front panel Voltmeter for the corresponding channel. The BOP output voltage should respond smoothly, from the maximum negative output voltage, through zero, to the maximum positive output voltage of the BOP. Verify that the VOLTAGE MODE/VOLTAGE LIMIT indicator for the corresponding channel is green (indicating Voltage Mode).
6. Apply voltage (3.5 to 24V) across pins 50 and 48 (return) of the PC 15 programming connector. Verify that front panel VOLTAGE and CURRENT meters for the channel under test show 0V and 0A, respectively.
7. Set the a-c POWER switch for channel under test to OFF.

4. THE COM OUTPUT TERMINALS OF THE BOP 2X-D MAY EITHER FLOAT OR BE GROUNDED. Leave the output terminal floating when an external, grounded device is used at either the programming input or the output, or for a grounded load. For noise reduction ground a single return terminal on either the programming device, the BOP or the load configuration. See "D-C Signal Ground." on page 3 for the maximum allowable floating voltage for the COM output terminal.

8. Connect a short circuit rated for the nominal output current between the OUTPUT and COMMON terminals at the rear panel.
9. At the rear panel of the channel under test, remove the PC 15 programming connector and modify as described for current control (see PAR. 4.2, step 1) and reinstall PC 15 at rear panel.
10. Set the a-c POWER switch for channel under test to ON.
11. Adjust the external programming voltage between +10V and -10V while observing the front panel Ammeter. The BOP output current should respond smoothly, from the maximum negative output current, through zero, to the maximum positive output current of the BOP channel. Verify that the CURRENT MODE/CURRENT LIMIT indicator for the corresponding channel is green (indicating Current Mode).
12. Apply voltage (3.5 to 24V) across pins 50 and 48 (return) of the PC 15 programming connector. Verify that front panel VOLTAGE and CURRENT meters for the channel under test show 0V and 0A, respectively.
13. Remove the short circuit from the output terminals and repeat steps 1 through 12 with channel selector switch set to CHANNEL 2.
14. Set a-c POWER circuit breaker/switch OFF. Remove the short circuit from the output terminals. This concludes the preliminary check-out of the BOP.

3.3. INSTALLING THE POWER SUPPLY. These models are shipped with fixed angle brackets and chassis slide support bars installed and are ready for mounting in a 19-inch rack.

3.4. CONNECTIONS. Connections to the load are made using the rear panel terminations.

LOAD CONNECTIONS. Connect the load between OUT (output) and COM (common) terminals at the rear panel. **Sense connections are required; otherwise the unit will not operate properly.**

LOCAL SENSE CONNECTIONS. For local sensing the OUT and COM terminals are connected to the adjacent S (sense) terminals. The unit is shipped with local sensing links in place at the rear panel.

GROUNDING NETWORK. The unit is shipped with a link installed between GND NET and GND terminals at the rear panel to enable the Grounding Network. This network reduces noise/ripple that may be present at the output when the output is not grounded.

REMOTE SENSE CONNECTIONS. Remote sensing (connecting the corresponding S terminals to the OUT and COM terminations at the load instead of at the BOP) can compensate for load wire losses up to 0.5V per wire (0.25V per wire on models with rated output less than 20V). Remote sensing is recommended for minimum load effect in voltage mode for a remote load. Use twisted pairs: #22 AWG for output sense lines and wires rated for the nominal output current of the power supply for power leads. See full Operator Manual (see PAR. 1.1) for remote sensing requirements.

INPUT A-C CONNECTIONS. Install the line cord (supplied) at the rear panel and connect to 115V a-c, 60Hz (105V to 125V a-c, 47 to 63Hz) mains. Refer to the full Operator Manual (see PAR. 1.1). For operation at 104V a-c, 208V a-c or 230V a-c refer to the full Operator Manual (see PAR 1.1).

A-C GROUND. The 3-wire line cord with 3-prong safety plug (supplied), in combination with a properly grounded a-c power outlet, automatically grounds the BOP 2X-D case. If an adapter for a non-grounded outlet is used, the case must be grounded separately using the GND terminal at the rear panel terminal block. The ground wire must be rated for at least the BOP input current (as noted on nameplate at rear of unit).

D-C SIGNAL GROUND. Specified ripple and noise figures for BOP power supplies are valid only with the COM side of the output load circuit returned to a ground point. The BOP circuits, including output and programming terminals, have no d-c connection to the chassis.

The COM terminal of each BOP channel can be “floated” up to 250 volts (d-c or peak) off chassis ground. The common mode current (leakage from output to ground) is less than 50 μ A (rms) or 5 mA (p-p) at 115V a-c, 60 Hz power input. To avoid common mode current from affecting the BOP output, the system (including the programming device, if used, load, and BOP) can have a single connec-

tion to ground (earth ground). The d-c ground wire must be rated for the nominal output current of the BOP (e.g., for BOP 20-10D, use rating of 10A).

Multiple signal grounds in the system may cause “ground-loop” and instability problems, since noise signals develop across the impedances between the multiple ground points. The exact physical location of the “best” single ground point must be carefully selected for minimum ripple/noise output and to avoid the possibility of output current flowing through the return path of an external programming signal.

REAR PROGRAMMING CONNECTOR, PC 15. Control of each channel is via the associated rear panel programming connector. (See Figure 5). Table 1 lists the functions of each terminal. For more details, refer to the BOP 2X20-10D Operator Manual (see PAR. 1.1).

TABLE 1. REAR PROGRAMMING CONNECTOR TERMINAL FUNCTIONS

TERMINAL (Figure 3)	FUNCTION
1	Current Limit Reference
3	Voltage Limit Reference
15 13 2 4	<p>Preamp “B”</p>
11 9 5 7	<p>Preamp “A”</p>
6	+E _O Limit Input
8	+I _O Limit Input
32	-E _O Limit Input
34	-I _O Limit Input
10	Current Monitoring
20	Voltage Monitoring
12, 14	Voltage Mode Compensating Terminals
16, 18	Current Mode Compensating Terminals
17	Voltage Comparison Amp Input
19	Current Comparison Amp Input
21	On-off Controlling Logic for the isolated on-off port, or Non-isolated on-off control
22	-10V Reference Voltage 4mA Max
28	+10V Reference Voltage 4mA Max

**TABLE 1. REAR PROGRAMMING CONNECTOR
TERMINAL FUNCTIONS (CONTINUED)**

TERMINAL (Figure 3)	FUNCTION
23, 25, 27, 29, 31, 33	Sensing Common
24	Circuit Breaker Control
26, 36	Turn-off Signal Output
30	Voltage Mode/Current Mode control
35	Local/Remote control
37	+5V
38	I _O Limit Flag
39	E _O Limit Flag
40	E _O Mode Flag
42	I _O Mode Flag
41	Non-isolated Turn-off Signal Input
43, 44, 45	Not Used.
46	/ON-OFF_FLAG
47, 49	Optically Isolated Turn-off Signal Input
48	ISO_GND
50	ON-OFF_CTRL

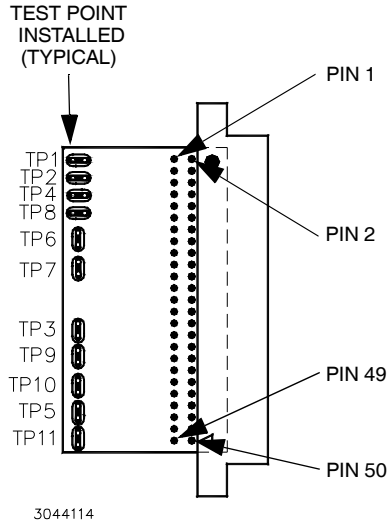

P/N 195-0121
PIN AND TEST POINT LOCATIONS

**FIGURE 2. REAR PROGRAMMING CONNECTOR, PIN
AND TEST POINT LOCATIONS**

3.5. COOLING. The components in the BOP 2X-D power supply rely on forced air cooling. FRONT AND REAR PANEL OPENINGS AND THE TOP OF THE CASE **MUST BE KEPT CLEAR FROM ALL OBSTRUCTIONS TO ENSURE AIR CIRCULATION.** Periodic cleaning of the interior of the power supply is recommended. If the BOP 2X-D is rack-mounted or installed into confined spaces, care must be taken that the ambient temperature (the temperature immediately surrounding the power supply) does not rise above 55°C (~131°F).

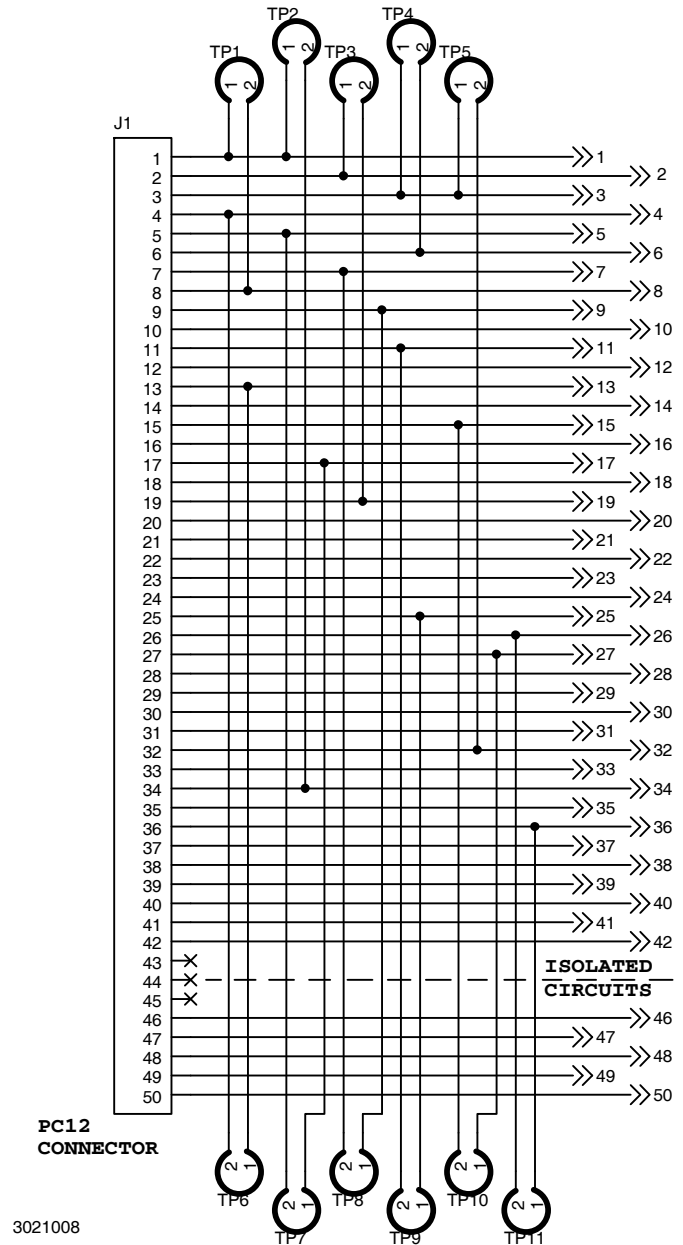

**FIGURE 3. REAR PROGRAMMING CONNECTOR,
WIRING DIAGRAM**

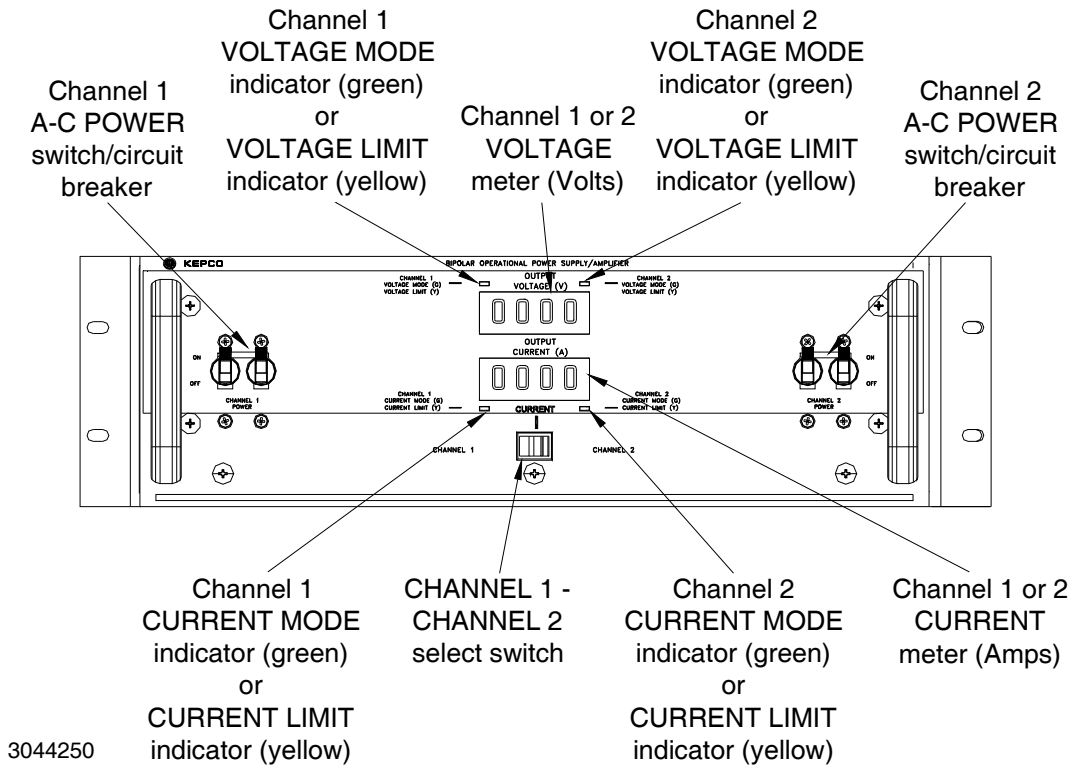

FIGURE 4. BOP 2X-D SERIES, FRONT PANEL CONTROLS AND INDICATORS

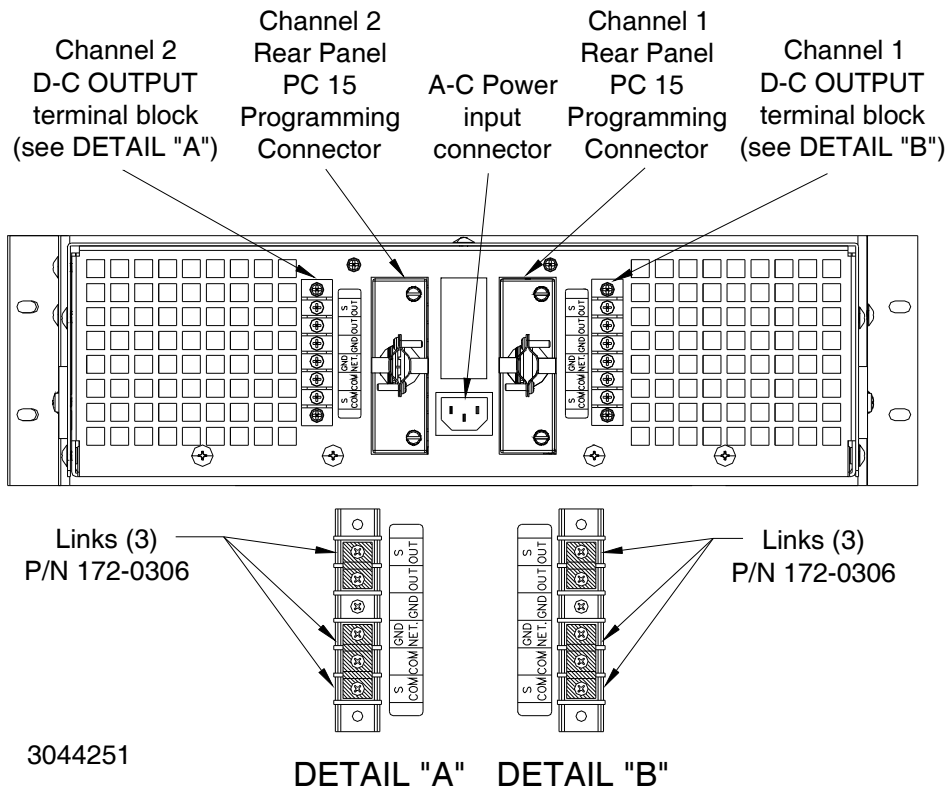

FIGURE 5. BOP 2X-D SERIES REAR PANEL TERMINATIONS

IV — OPERATION

Each BOP channel is controlled by external signals applied to the PC 15 rear programming connector, together with the installation or removal of wire jumpers to the PC 15 pins as dictated by the application.

The following paragraphs provide simple procedures to control a BOP channel output voltage (PAR. 4.1) or output current (4.2). Refer to the Operator's Manual (see PAR. 1.1) for complete instructions

Voltage and current limits are set by default to a fixed value approximately 10% above the nominal output voltage and current of the unit. Refer to the Operator's Manual (see PAR. 1.1) to use external reference signals in the 0 to +10V range to remotely program/control limits between 0.2% and 110% of nominal output,

NOTE: The PC 15 rear programming connector for the BOP channel in use must be adapted for the application and installed to enable control of the channel (see "Rear Programming Connector, PC 15." on page 3. Refer to PAR. 4.1 or 4.2 for simple Voltage Mode or Current Mode control. Refer to the Operator's Manual (see PAR. 1.1) for other control configurations.

4.1. VOLTAGE MODE OPERATION WITH CURRENT LIMITING. The BOP channel may be used as a stabilized (d-c) source of positive or negative voltage with output current limiting (for either polarity) when adapted for the application at hand.

Always monitor the front panel meters while adjusting output voltage/current.

1. Make the connections to the PC 15 rear panel programming connector as shown in Figure 6 for inverting voltage mode control.
 - a. If installed, remove the wire jumper between pins 30 and 27 of the PC 15.
 - b. Connect a 10K Ohm resistor (0.1%, 1/4W, metal film) to PC 15 pin 9.
 - c. Connect a $\pm 10V$ programming voltage source between the unconnected end of the 10K Ohm resistor and PC 15 pin 23.
 - d. Use insulation tubing for the resistor leads and connections. Refer to Table 1 and Figures 2 and 3 for PC 15 details and signal allocations.
2. Install the PC 15 programming connector at the rear panel (see Figure 5).
3. Set the CHANNEL:1 - CHANNEL 2 selector switch so the front panel meters display the BOP channel in use.
4. Set AC POWER switch/circuit breaker for the desired channel to ON (see Figure 4). **CAUTION: DO NOT repeatedly toggle the POWER on/off switch as this may cause unit to fault.** If actuator does not lock when released, wait a few seconds before trying again. The circuit breaker is "trip-free;" if overload exists, contacts cannot be held closed by actuator.
5. While monitoring the BOP front panel meters, adjust the $\pm 10V$ programming voltage source as necessary to apply output voltage to the load. The configuration shown in Figure 6 is inverting, i.e., +10V in produces $-E_{O\text{nom}}$ out, $-10V$ in produces $+E_{O\text{nom}}$ out.

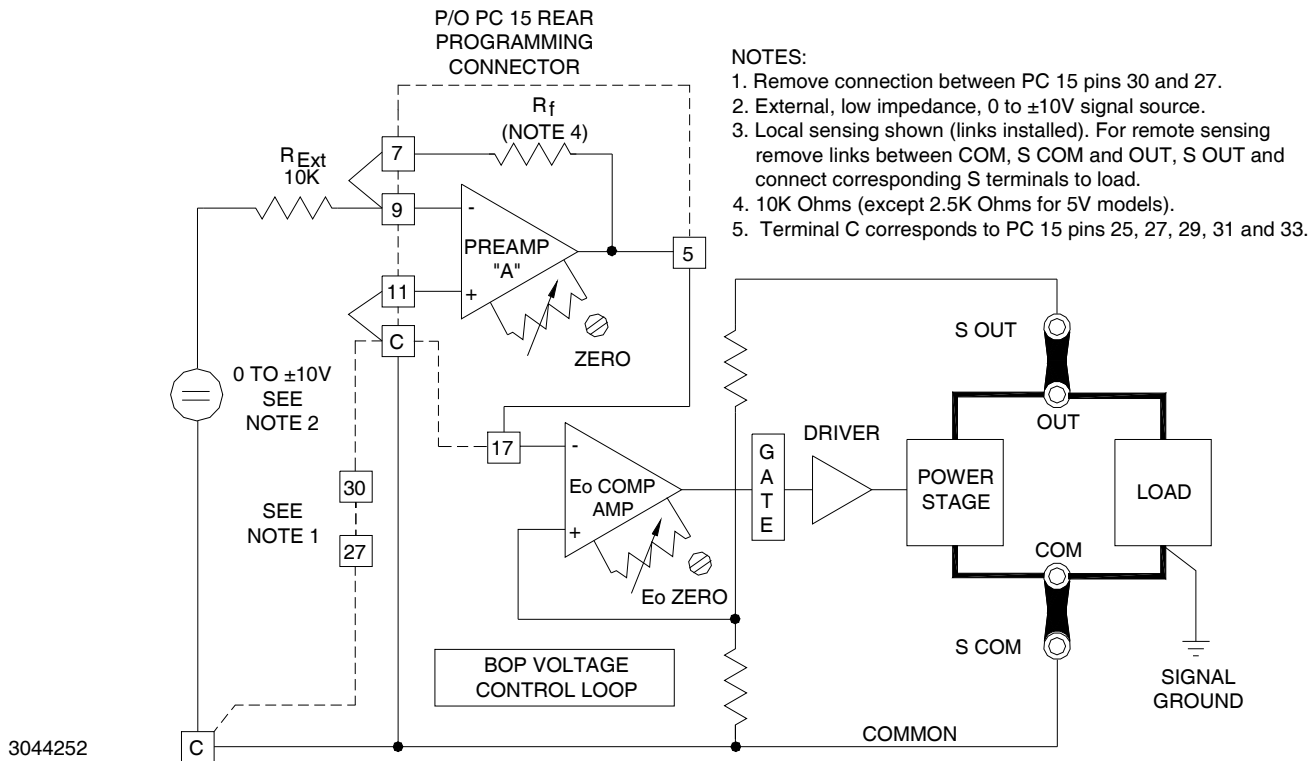

NOTES:

1. Remove connection between PC 15 pins 30 and 27.
2. External, low impedance, 0 to $\pm 10V$ signal source.
3. Local sensing shown (links installed). For remote sensing remove links between COM, S COM and OUT, S OUT and connect corresponding S terminals to load.
4. 10K Ohms (except 2.5K Ohms for 5V models).
5. Terminal C corresponds to PC 15 pins 25, 27, 29, 31 and 33.

FIGURE 6. BOP 2X-D SERIES CHANNEL, OUTPUT VOLTAGE CONTROL

4.2. CURRENT MODE OPERATION WITH VOLTAGE LIMITING. The BOP channel may be used as a stabilized d-c source of positive or negative current, with output voltage limiting (for either polarity), pre-selected for the application at hand. Always monitor the front panel meters while adjusting output voltage/current.

1. Make the connections to the PC 15 rear panel programming connector as shown in Figure 7 for inverting current mode control.
 - a. Install a wire jumper between pins 30 and 27 of the PC 15.
 - b. Connect a 10K Ohm resistor (0.1%, 1/4W, metal film) to PC 15 pin 13.
 - c. Connect a $\pm 10V$ programming voltage source between the unconnected end of the 10K Ohm resistor and PC 15 pin 25.
 - d. Use insulation tubing for the resistor leads and connections. Refer to Table 1 and Figures 2 and 3 for PC 15 details and signal allocations.

2. Install the PC 15 programming connector at the rear panel (see Figure 5).
3. Set the CHANNEL:1 - CHANNEL 2 selector switch so the front panel meters display the BOP channel in use.
4. Set AC POWER switch/circuit breaker for the desired channel to ON (see Figure 4). **CAUTION: DO NOT repeatedly toggle the POWER on/off switch as this may cause unit to fault.** If actuator does not lock when released, wait a few seconds before trying again. The circuit breaker is "trip-free;" if overload exists, contacts cannot be held closed by actuator.
5. While monitoring the BOP 2X-D front panel meters, adjust the $\pm 10V$ programming voltage source as necessary to apply output current to the load. The configuration shown in Figure 7 is inverting, i.e., +10V in produces $-I_{O\text{nom}}$ out, -10V in produces $+I_{O\text{nom}}$ out.

4.3. ADDITIONAL FEATURES. The following features of the BOP 2X-D power supply are covered in the full Operator Manual (see PAR. 1.1).

- BOP Channel Operation with Remote Control of the Voltage Control Channel
- BOP Channel Operation with Remote Control of the Current Control Channel
- Using the BOP Channel as an Amplifier

- Remote Control of the BOP Channel Current Limit
- Remote Control of the BOP Channel Voltage Limit
- Series and Parallel Connection of BOP Channels
- Remote On-Off Control

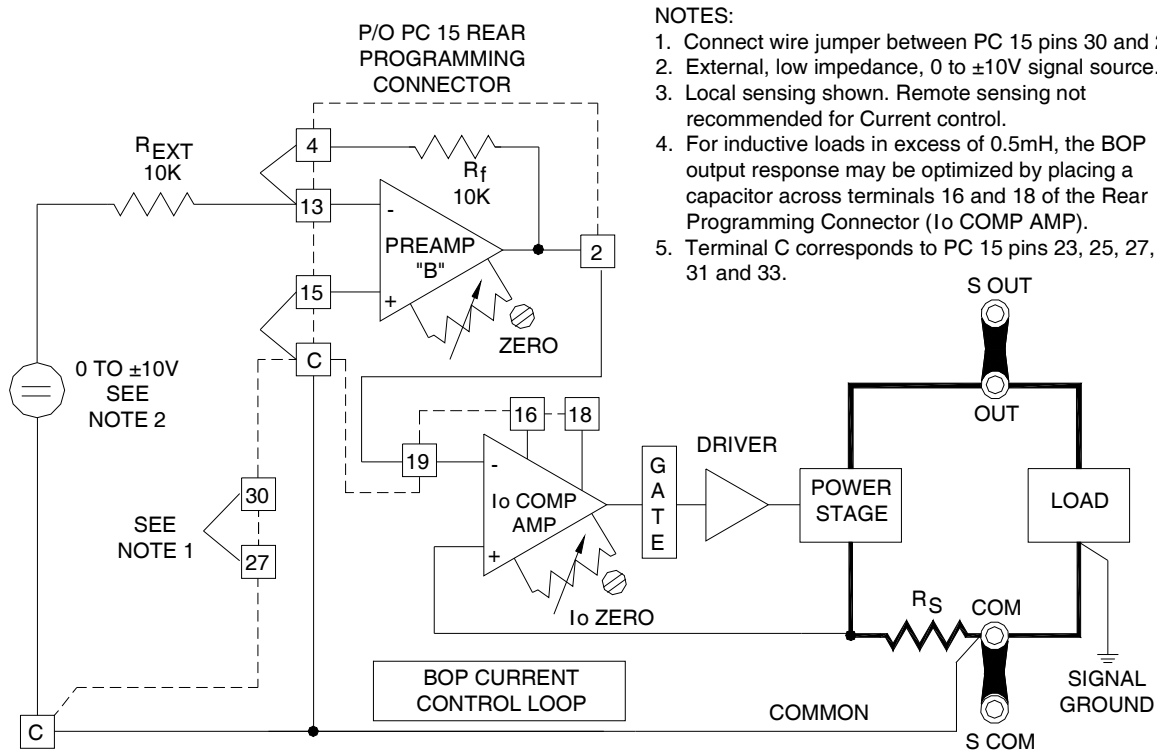

- NOTES:
1. Connect wire jumper between PC 15 pins 30 and 27.
 2. External, low impedance, 0 to ±10V signal source.
 3. Local sensing shown. Remote sensing not recommended for Current control.
 4. For inductive loads in excess of 0.5mH, the BOP output response may be optimized by placing a capacitor across terminals 16 and 18 of the Rear Programming Connector (I_o COMP AMP).
 5. Terminal C corresponds to PC 15 pins 23, 25, 27, 29, 31 and 33.

FIGURE 7. BOP 2X-D SERIES CHANNEL, OUTPUT CURRENT CONTROL

3044253