

INSTRUCTION MANUAL



KEPCO An ISO 9001 Company.

**KIT
DIN AE
-800S**

DIN-RAIL MOUNTING KIT FOR SERIES AE-800S

DESCRIPTION. Kepco KIT, Model DIN AE-800S contains two preassembled mounting clips and associated hardware used to install AE-800 Series power supplies on a DIN rail. The "S" suffix is for mounting horizontally along the short dimension (width) as shown in Figure 1. Outline dimensions are shown in Figure 4.

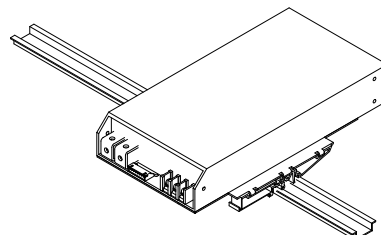

3043940

FIGURE 1. S SUFFIX ORIENTATION

TABLE 1. COMPONENTS SUPPLIED

KIT MODEL NO.	MOUNTING PLATE (QTY 1) PART NO.	CLIP (QTY 2) PART NO.	SCREW, SEMS (QTY 3) PART NO.	LOCK-WASHER (QTY 2) PART NO.	FLAT WASHER (QTY 2) PART NO.	NUT (QTY 2) PART NO.	SCREW (QTY 2) PART NO.
DIN AE-800S	128-2460	108-0362	501-0080 (M4 X 6 PHPH)	103-0015 (NO. 6, Int. Tooth)	103-0028 (NO. 6)	102-0004 (Hex, 1/4" x 6-32)	101-0408 (FH 6-32 x 5/16")

INSTALLING KIT. Attach the preassembled mounting clips to the power supply using the hardware supplied (see Figure 3). The clips may be mounted with the release lever on either side to facilitate removal.

INSTALLING POWER SUPPLY ON DIN RAIL. To mount the power supply on the rail insert one end of both clips under one edge of the rail, then snap the other end of the two clips into place (see Figure 2A). If the DIN rail is mounted on a flat surface, the DIN rail must be raised at least 0.65 in. above flat surface to avoid interference during installation/removal.

REMOVING POWER SUPPLY FROM DIN RAIL. While grasping the power supply with one hand, use a screwdriver to apply leverage towards the right as shown in Figure 2B to disengage each clip from the rail. Where mounting clips are close together, it may be necessary to apply leverage with two screwdrivers simultaneously.

A — INSTALLATION

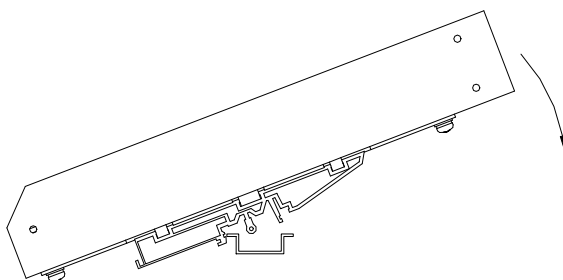

3043941

B — REMOVAL

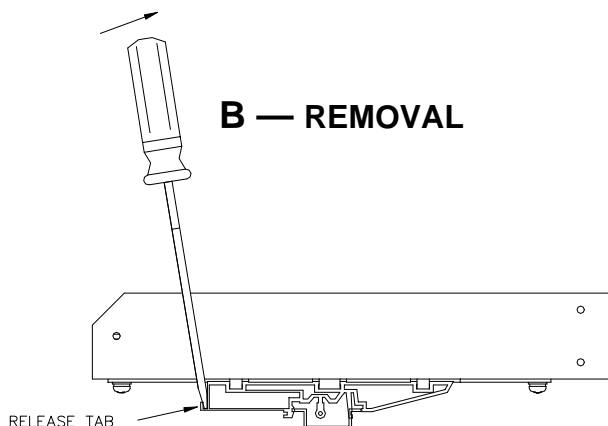

FIGURE 2. INSTALLATION AND REMOVAL OF POWER SUPPLY FROM DIN RAIL

KEPCO, INC. ● 131-38 SANFORD AVENUE ● FLUSHING, NY. 11355 U.S.A. ● TEL (718) 461-7000 ● FAX (718) 767-1102
<http://www.kepcopower.com> ● email: hq@kepcopower.com

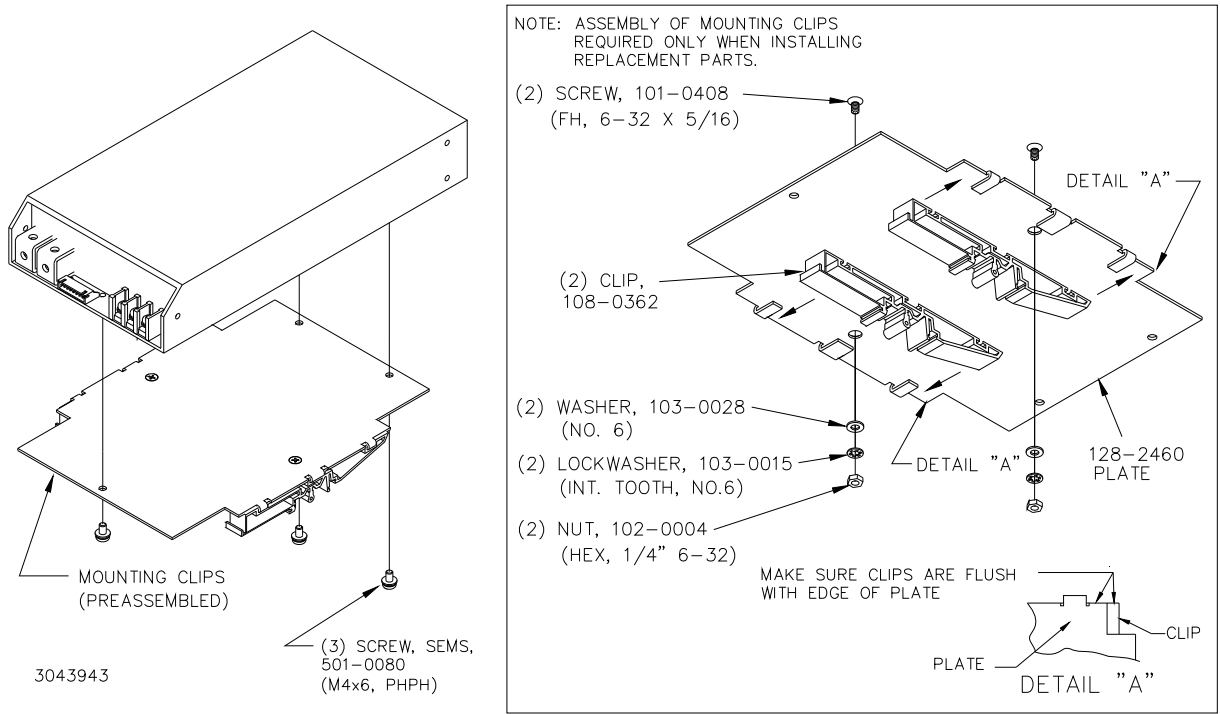

FIGURE 3. INSTALLATION OF KIT ON POWER SUPPLY

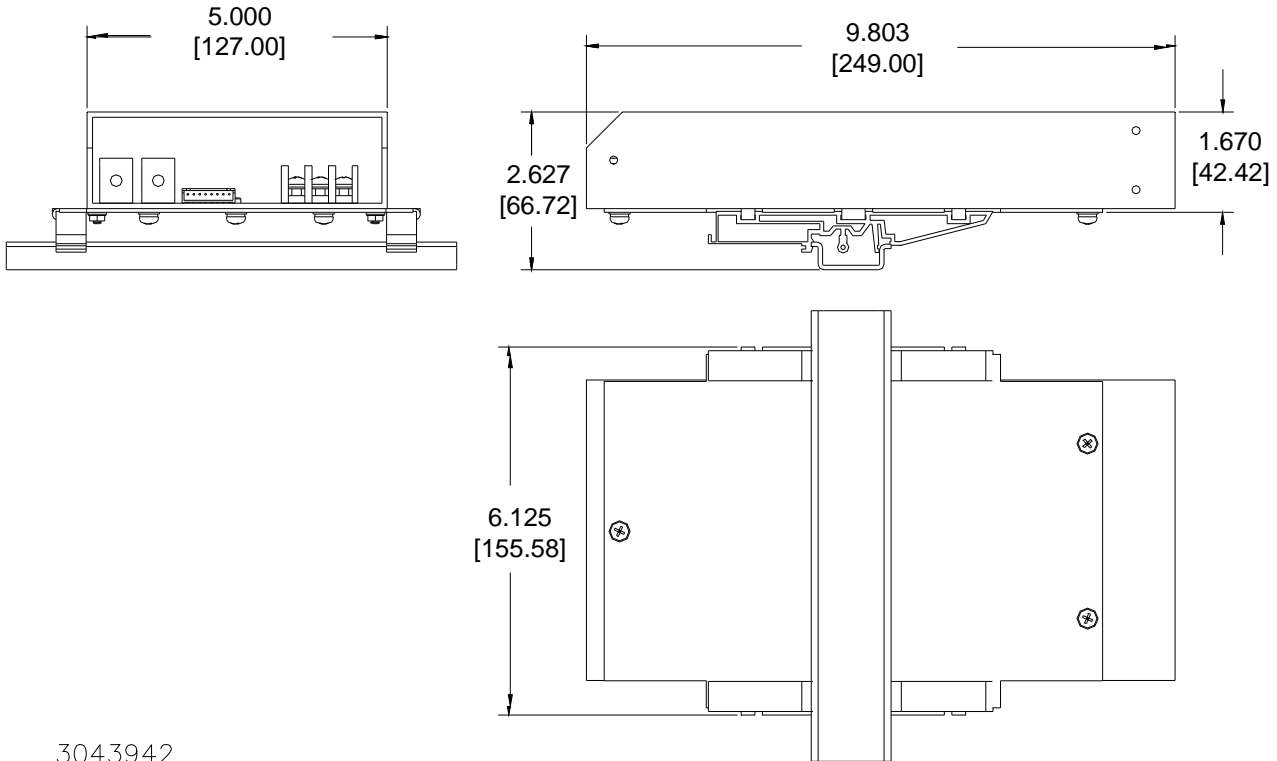

FIGURE 4. POWER SUPPLY WITH KIT INSTALLED, OUTLINE DIMENSIONS