

INSTRUCTION MANUAL



KEPCO An ISO 9001 Company.

**KIT
DIN AE
-3000L**

DIN-RAIL MOUNTING KIT FOR SERIES AE-3000W

DESCRIPTION. Kepco KIT, Model DIN AE-3000L contains two mounting clips preassembled to a mounting plate and associated hardware used to install AE-3000 Series power supplies on a DIN rail. The -3000 suffix is for the 3000 Watt Series. The "L" suffix is for mounting horizontally along the long dimension (length) as shown in Figure 1. Outline dimensions are shown in Figure 4.

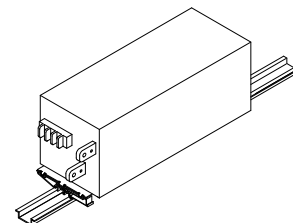

FIGURE 1. L SUFFIX ORIENTATION

TABLE 1. COMPONENTS SUPPLIED

KIT MODEL NO.	MOUNTING PLATE (QTY 2) PART NO.	CLIP (QTY 2) PART NO.	SCREW, SEMS (QTY 4) PART NO.	SCREW (QTY 2) PART NO.	WASHER, FLAT (QTY 2) PART NO.	WASHER, LOCK (QTY 2) PART NO.	NUT (QTY 2) PART NO.
DIN AE-3000L	128-2441	108-0362	101-0463 (M4 X 8 PHPH)	101-0408 (6-32 X 5/16, FLPO)	103-0028 (NO. 6,)	103-0015 (NO. 6, INT. TOOTH)	102-0004 (6-32 x 1/4, ACF)

INSTALLING KIT. Attach the two preassembled mounting plate with clips to the power supply using the hardware supplied (see Figure 3).

INSTALLING POWER SUPPLY ON DIN RAIL. To mount the power supply on the rail insert one end of both clips under one edge of the rail, then snap the other end of the two clips into place (see Figure 2A).

REMOVING POWER SUPPLY FROM DIN RAIL. While grasping the power supply with one hand, use a screwdriver to apply leverage towards the left as shown in Figure 2B to disengage each clip from the rail. Where mounting clips are close together, it may be necessary to apply leverage with two screwdrivers simultaneously.

A — INSTALLATION

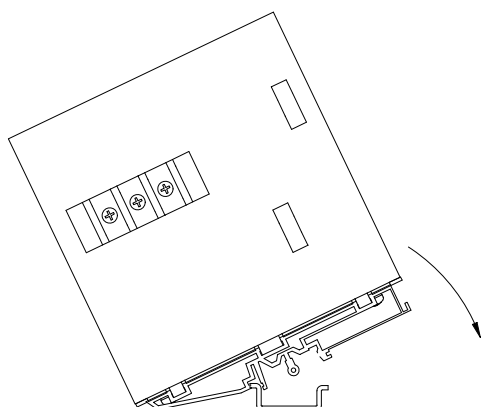

B — REMOVAL

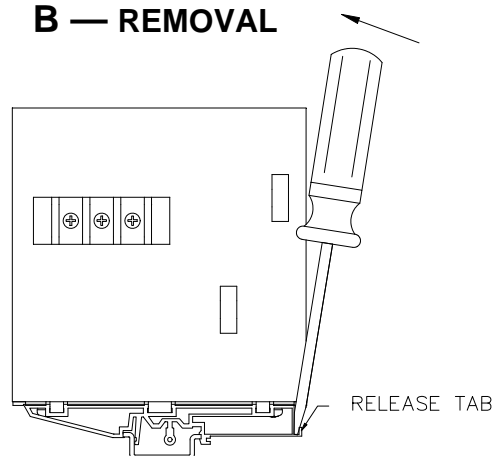
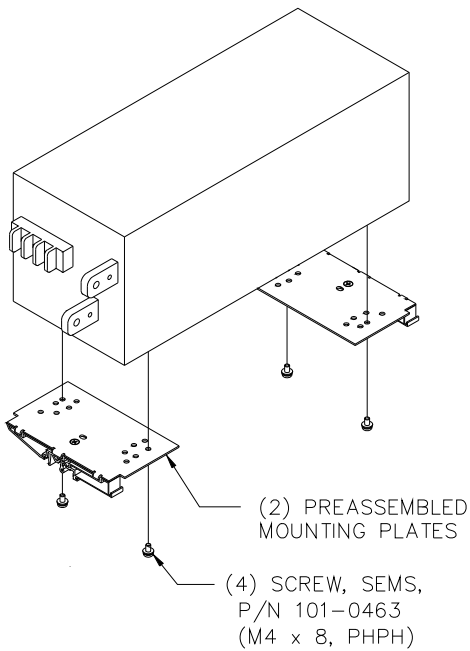

FIGURE 2. INSTALLATION AND REMOVAL OF POWER SUPPLY FROM DIN RAIL

KEPCO, INC. ● 131-38 SANFORD AVENUE ● FLUSHING, NY. 11355 U.S.A. ● TEL (718) 461-7000 ● FAX (718) 767-1102
http://www.kepcopower.com ● email: hq@kepcopower.com



3043934

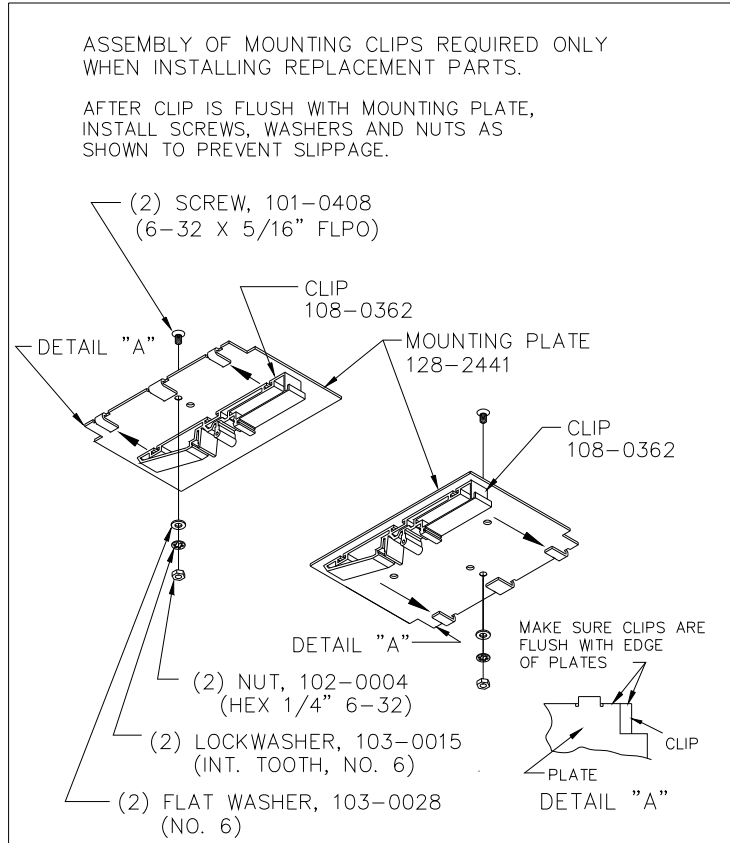
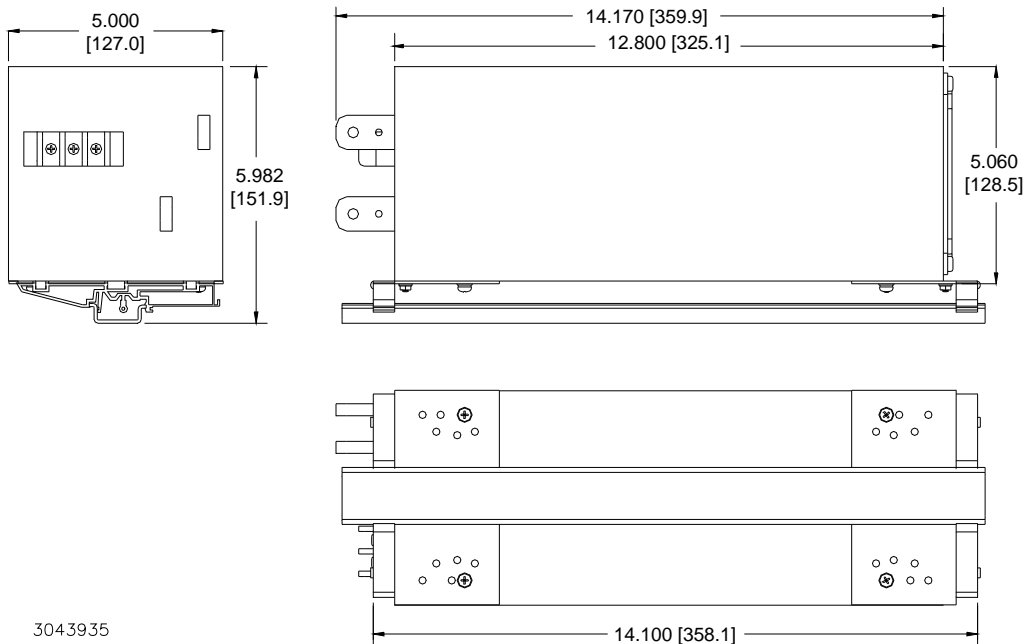

FIGURE 3. INSTALLATION OF KIT ON AE POWER SUPPLY



3043935

FIGURE 4. AE-3000 POWER SUPPLY WITH KIT INSTALLED, OUTLINE DIMENSIONS