

INSTRUCTION SHEET

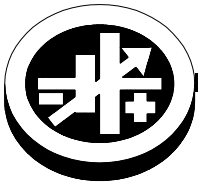

KEPCO An ISO 9001 Company.

**MA
RKW/AK
-150/200V**

MOUNTING ADAPTER RKW/AK-150V, RKW/AK-200V

DESCRIPTION. The Model MA RKW/AK-150V is for 150W AK power supplies and Model MA RKW/AK-200V is for 200W AK power supplies. Each Mounting Adapter includes an adapter plate and mounting screws that allow a vertically-mounted 150W or 200W AK power supply to be easily substituted for a vertically-mounted 150W RKW power supply. Note that some AK dimensions may exceed corresponding RKW dimensions; verify proper fit prior to installation. Mount the adapter plate to the AK power supply using the screws and spacers provided (see Figure 1), then install the adapter plate in place of the RKW power supply using the screws previously used to mount the RKW power supply.

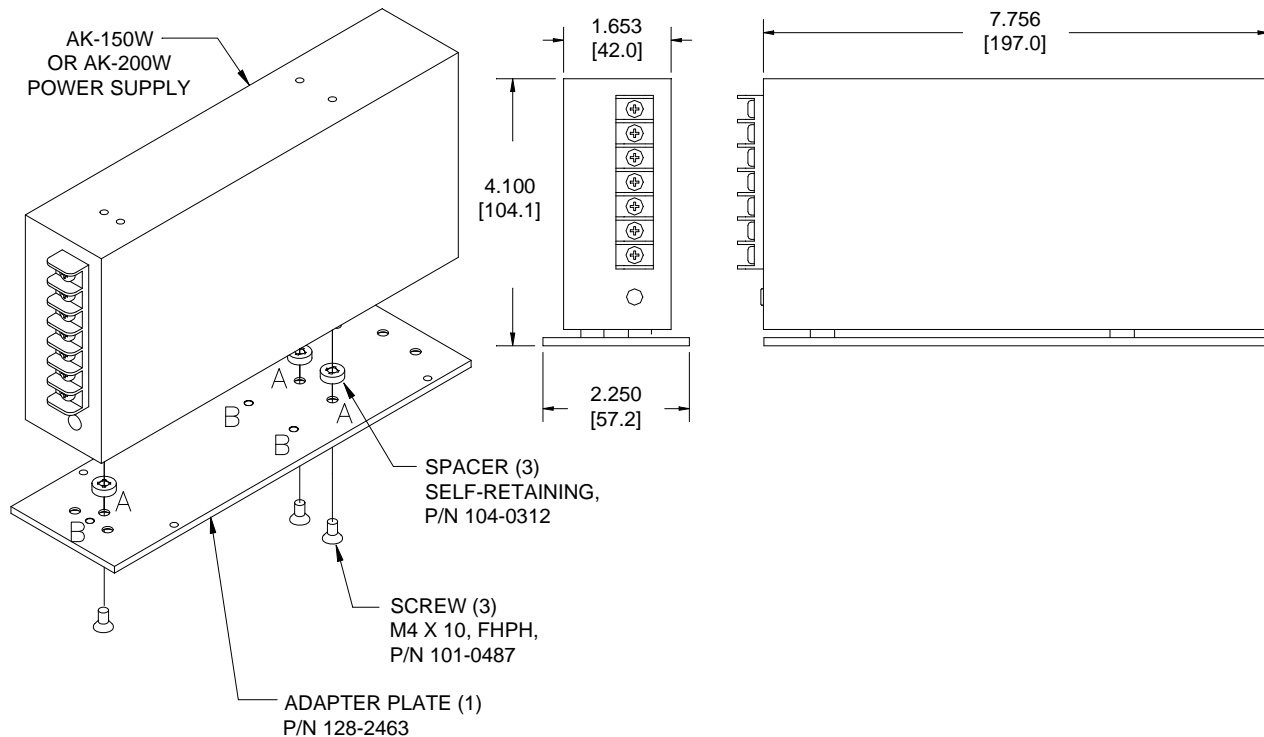

NOTES:

1. MOUNT ADAPTER PLATE TO POWER SUPPLY AT HOLES "A" USING TWO SPACERS P/N 104-0312, AND TWO SCREWS P/N 101-0487.
2. REMOVE RKW POWER SUPPLY AND SAVE MOUNTING SCREWS, THEN INSTALL ADAPTER PLATE WITH AK POWER SUPPLY ATTACHED AT HOLES "B" USING MOUNTING SCREWS SAVED. (MOUNTING SCREWS ARE M4, LENGTH NOT TO EXCEED 8MM.)

3043904

FIGURE 1. ADAPTER PLATE INSTALLATION

KEPCO, INC. ● 131-38 SANFORD AVENUE ● FLUSHING, NY. 11355 U.S.A. ● TEL (718) 461-7000 ● FAX (718) 767-1102
<http://www.kepcopower.com> ● email: hq@kepcopower.com