

INSTRUCTION MANUAL



KEPCO An ISO 9001 Company.

**KIT
219-0567**

WIRING KIT FOR SERIES AK-650, AK-1000

1. DESCRIPTION.

Kepeco KIT, Model 219-0567 supplies a mating connector and preterminated wires that allow convenient wiring of AK-650 or AK-1000 Series power supplies.

2. MATERIAL SUPPLIED (SEE TABLE 1.)

Table 1 lists the contents of this kit.

TABLE 1. MATERIAL SUPPLIED

ITEM	DESCRIPTION	KEPCO PART NUMBER	QUANTITY
Mating Connector	Mates with 16-pin power supply connector.	142-0609	1
Wire	24 AWG. Six (6) wires are 36" long, terminated at one end with a connector contact. Four (4) wires, 2" long, for local sensing and remote on/off are terminated at both ends with connector contacts. One (1) wire is 16" long and terminated at both ends for current share between two units.	N/A	11
Instruction Sheet	Describes the contents and use of KIT 219-0567.	228-1802	1

3. INSTALLATION

1. Refer to the applicable data sheet for connection details for the desired function. The data sheets are available for download from the Kepeco web site as follows:

AK-650 <http://www.kepcopower.com/akmod.htm>

AK-1000 <http://www.kepcopower.com/akmod.htm>

2. Remove mating connector pre-installed on connector CN9 of the power supply.
3. Install terminated ends of wires into mating connector provided in this kit as specified in Table 2 to activate desired power supply function. Refer to Figure 1 for pin locations (observe key location to identify proper pin). Note that removal of default jumpers means that function must be restored by making connections via the mating connector using the wires supplied.
4. After connections are made, install mating connector on CN9.

KEPCO, INC. ● 131-38 SANFORD AVENUE ● FLUSHING, NY. 11355 U.S.A. ● TEL (718) 461-7000 ● FAX (718) 767-1102
<http://www.kepcopower.com> ● email: hq@kepcopower.com

NOTES:

1. OBSERVE LOCATION OF KEYS TO ENSURE PIN NUMBERS ARE CORRECT.
2. WIRES SHOWN INSTALLED FOR LOCAL SENSING: PINS 1-2 AND 3-4.
3. WIRES SHOWN INSTALLED FOR REMOTE OPERATION INHIBITED (POWER SUPPLY ON): PINS 5-7 AND 9-10.

3044037

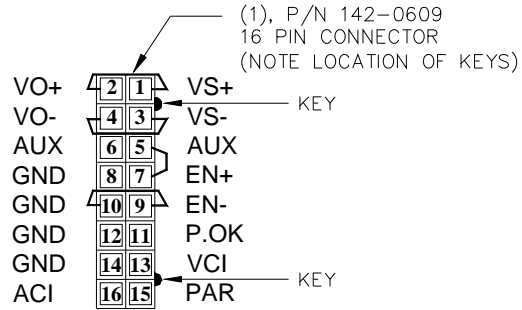

FIGURE 1. MATING CONNECTOR FOR CN9

TABLE 2. FUNCTIONS SUPPORTED BY KIT 219-0567

Function Supported	Power Supply Connector CN9	
	From Pin	To Pin
Local Sense	1 (VS+)	2 (VO+)
	3 (VS-)	4 (VO-)
Remote Sense	1 (VS+)	load
	3 (VS-)	load
Power Supply ON (no remote enable)	9 (EN-)	10 GND ⁽¹⁾
	7 (EN+)	5 (AUX) ⁽¹⁾
Remote Enable	5 (AUX) ⁽¹⁾	(2)
	7 (EN+)	(2)
	9 (EN-)	(2)
	8 (GND) ⁽¹⁾	(2)
Current Share ⁽²⁾⁽³⁾	16 (ACI)	16 (ACI) ⁽²⁾
	15 (PAR)	16 (PAR) ⁽²⁾
	14 (GND) ⁽¹⁾	(2)
Current Programming using External voltage or resistance	16 (ACI)	(2)
	14 (GND) ⁽¹⁾	(2)
Voltage Programming using External voltage or resistance	13 (VCI)	(2)
	14 (GND) ⁽¹⁾	(2)
Power OK monitor	11 (P.OK)	(2)
	6 (AUX) ⁽¹⁾	(2)
	8 (GND) ⁽¹⁾	(2)

(1) Alternate pins for AUX (5, 6) and GND (8, 10, 12, 14) are available. See Figure 1.
 (2) See applicable data sheet for connections.
 (3) Current sharing between two power supplies requires two separate kits.