

OPERATOR'S MANUAL

ATE 1/4 RACK (50W, 100W)

POWER SUPPLY

AUTOMATIC TEST EQUIPMENT

KEPCO INC.
An ISO 9001 Company.

MODEL



50W

ATE 6-5, ATE 15-3, ATE 25-2,
ATE 36-1.5, ATE 55-1, ATE 75-0.7,
ATE 100-0.5, ATE 150-0.3

100W

ATE 6-10, ATE 15-6, ATE 25-4,
ATE 36-3, ATE 55-2, ATE 75-1.5,
ATE 100-1, ATE 150-0.7

IMPORTANT NOTES:

- 1) This manual is valid for the following Model and associated serial numbers:

MODEL	SERIAL NO.	REV. NO.
-------	------------	----------

- 2) A Change Page may be included at the end of the manual. All applicable changes and revision number changes are documented with reference to the equipment serial numbers. Before using this Instruction Manual, check your equipment serial number to identify your model. If in doubt, contact your nearest Kepco Representative, or the Kepco Documentation Office in New York, (718) 461-7000, requesting the correct revision for your particular model and serial number.
- 3) The contents of this manual are protected by copyright. Reproduction of any part can be made only with the specific written permission of Kepco, Inc.

Data subject to change without notice.

©2023, KEPCO, INC
P/N 228-1723-REV 6





INSTRUCTION MANUAL CORRECTION

Please note the following corrections to the standard Instruction Manual for ATE models plus all the other manuals for specials or “-MG” models derived from it as indicated:

A) PAR. 3.8 PARALLEL OPERATION OF ATE (-MG MODELS) POWER SUPPLIES

Add the following note:

NOTE THE FOLLOWING

CAUTION: When connecting units in parallel, use an external master ON/OFF circuit breaker or switch to simultaneously turn on/off all units connected in parallel. The individual circuit breakers should be left in the ON position working as an overcurrent and over-voltage protection circuit and should not be used as a power ON/OFF switch.

If the above recommendations are not met, the internal turn-off overshoot eliminator circuit could be damaged to the point where it is no longer operational.

B) SECTION III, FIGURES 3-4, 3-5, 3-6, 3-8, 3-10, 3-14, 3-15, 3-16, 3-20, 3-22, 3-25, 3-26, 3-28, 3-30

These diagrams show the load connected using remote sensing. For local sensing leave the links between TB201 terminals 2 (-) S and 3 (-) M and between terminals 5 (+) M and 6 (+) S in place. Disconnect the remote sensing wires from TB 201 terminals 2 (-) S and 6 (+) S to the load.

C) PAR. 3-37 through 3-90 REDUCING RISE TIME DELAY WHEN USING EXTERNAL PROGRAMMING, EITHER FAST OR SLOW MODE

To reduce the rise time delay, make sure that for the “low” level of the programming signal the output voltage has a small value, at least 0.1% of nominal (with the correct polarity).

D) PAR. 3-115. PROGRAMMING WITH REFERENCE TO THE NEGATIVE POWER SUPPLY OUTPUT

When the ATE power supply is used in FAST MODE, with a programming reference to the negative output of the unit (see PAR. 3-115 and Figure 3-29) some oscillation may be present at the output. This can be avoided by installing a ceramic capacitor between PC 12, pins 1 and 2. The capacitor value is model dependent, within the range 1.2nF to 4.7nF, and it must be rated for more than the nominal output voltage of the unit.

NOTES:

1. When the ceramic capacitor is installed at PC 12, pins 1 and 2, the 3-dB frequency bandwidth of the unit in FAST MODE is reduced by a factor of from 1.5 to 2.5. Correspondingly, the response time will be increased by the same factor.

2. To reduce the rise time delay, see C) above: REDUCING RISE TIME DELAY
3. To reduce the fall time delay, adjust the current limit to a higher value than maximum application current to ensure that for the "high" level of the programming signal the unit is not forced to enter current limit mode.
4. To prevent the unit from going into over-voltage protection and shutting down when the low impedance programming source is disconnected, install a 10 Kohm resistor (1%, 0.125W) at the input programming terminals of PC 12.
5. To reduce a-c line-related noise at the output, connect one of the following to the ATE chassis GND terminal.: 1) the return of the programming source, 2) the corresponding output terminal of the ATE, or 3) the corresponding Load terminal. In addition, make sure that all devices are tied to the same GND connection; it is recommended that all devices in use by powered by the same a-c outlet.

E) FIGURE 3-29 CORRECTIONS:

Ea:	6V to 100V models:	Ea = 0 to (-) 1V
	150V models:	Ea = 0 to (-) 0.5V
	325V models:	Ea = 0 to (-) 0.25V
Eb:	All models	Eb = 0 to 10V

F) PAR. 3-117 CORRECTIONS

PREAMP "A" is used to perform . . . signal back to the required level (0 to 10V).

G) PAR. 3-118 CORRECTIONS

Rb':	6V to 100V models	Rb' = 100K Ohms
	150V models	Rb' = 49.9K Ohms
	325V models	Rb' = 24.9K Ohms

H) PAR. 3-119 CORRECTIONS

Gain:	6V to 100V models	Gain = 10
	150V models:	Gain = 20
	325V models:	Gain = 40
Rf (ext):	6V to 100V models	Rf (ext) = 10K Ohms
	150V models:	Rf (ext) = 20K Ohms
	325V models:	Rf (ext) = 40.2K Ohms

For 325V models, add sentence to Note:

Note: The selected resistors . . . tolerance of 1%. Ra and Rb should have a power rating of 0.5W and voltage rating of 500V minimum. They should be wired . . .

J) PC 12 PIN FUNCTIONS

See Figure 1 for Pin functions of PC 12 connector for ATE 1/4 Rack Models. Also shown are connections for a prewired PC 12 connector, PC 13, allowing local control of the unit.

See Figure 2 for Pin functions of PC 12 connector for ATE 1/2, 3/4 and Full Rack Models. Also shown are connections for a prewired PC 12 connector, PC 14, allowing local control of the unit.

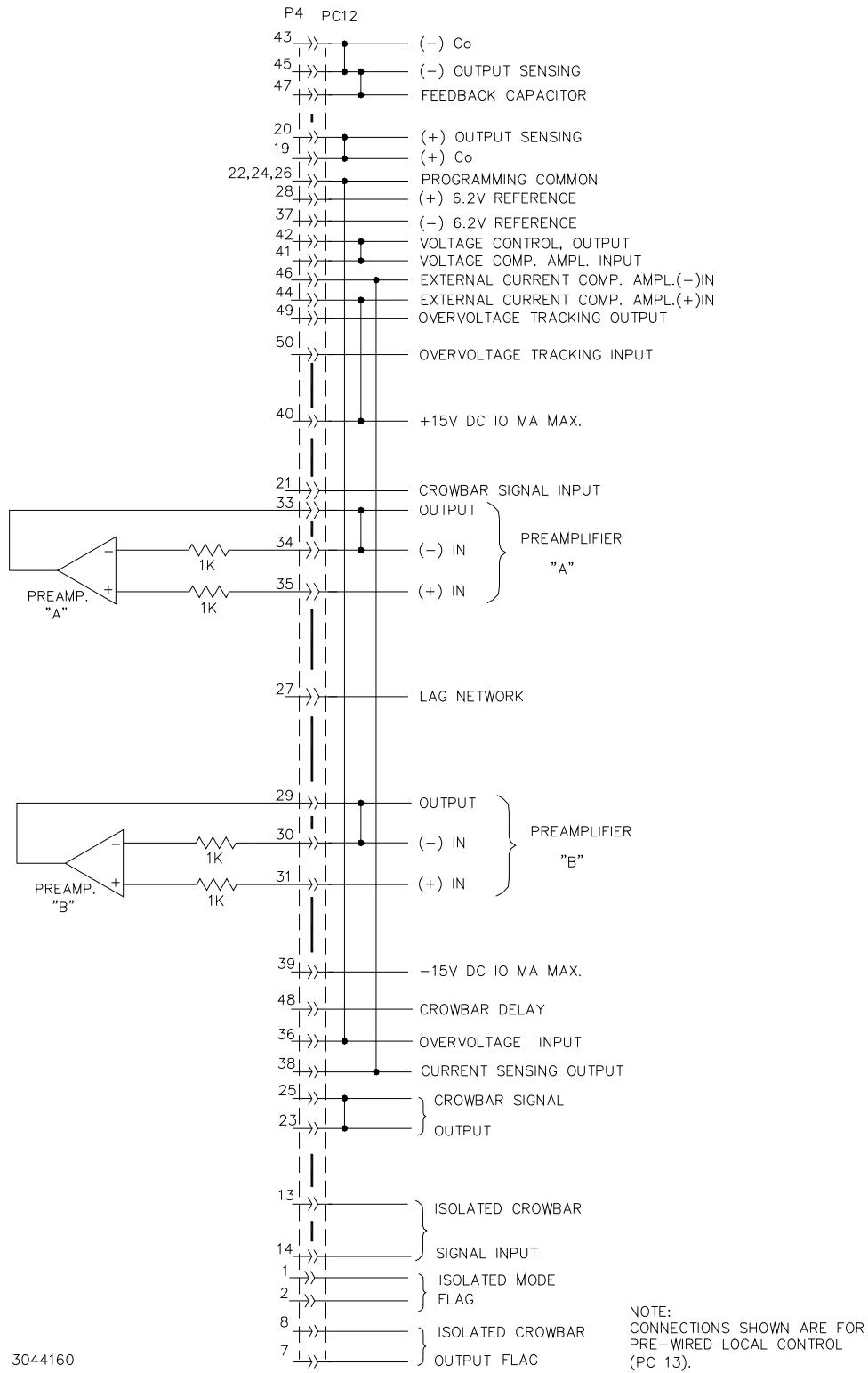
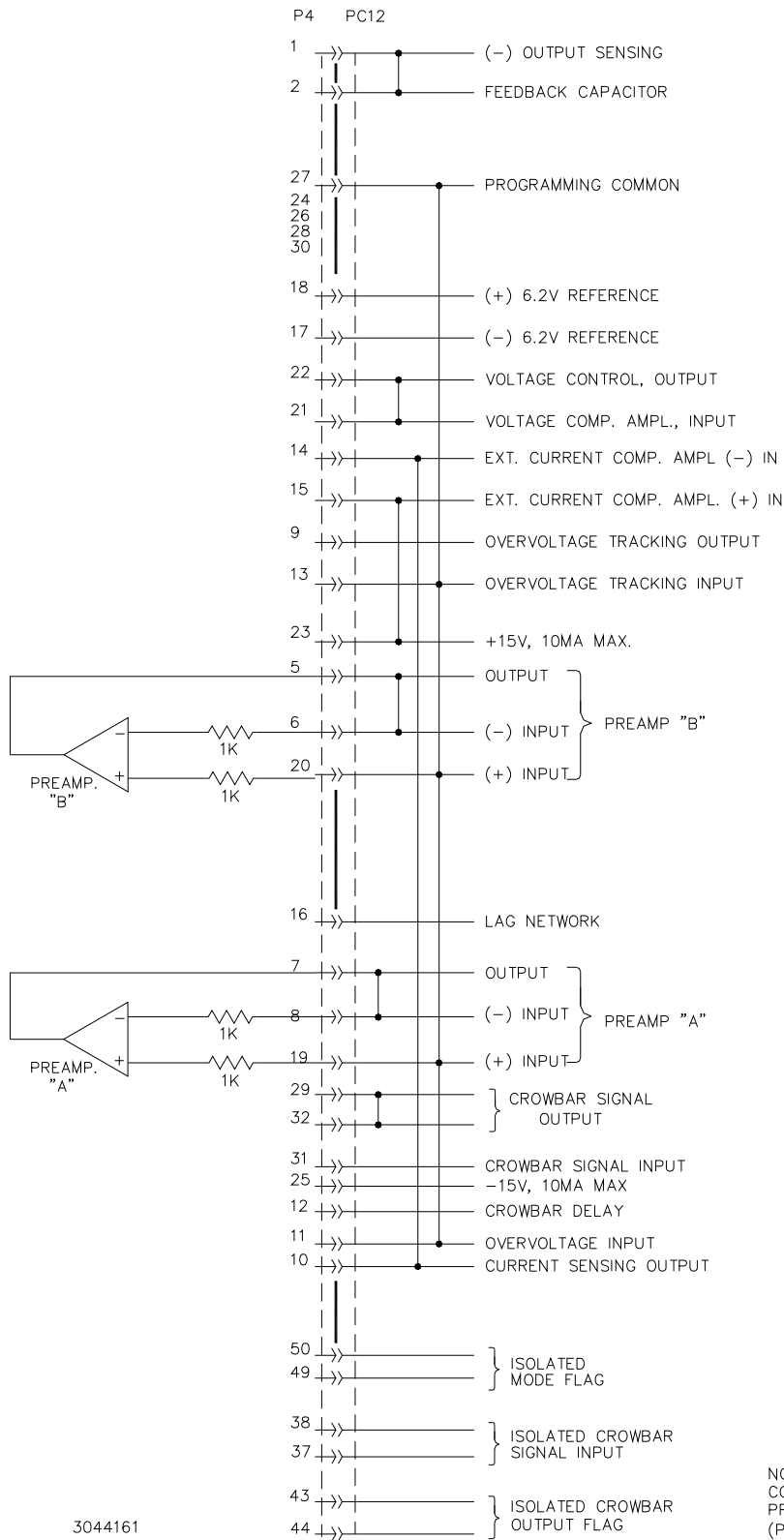

FIGURE 1. PC 12 PIN FUNCTIONS FOR 1/4 RACK MODELS SHOWING PRE-WIRED LOCAL CONTROL CONNECTIONS (PC 13)



NOTE:
CONNECTIONS SHOWN ARE FOR
PRE-WIRED LOCAL CONTROL
(PC 14).

3044161

FIGURE 2. PC 12 PIN FUNCTIONS FOR 1/2, 3/4 AND FULL RACK MODELS SHOWING PRE-WIRED LOCAL CONTROL CONNECTIONS (PC 14)

K) DIGITAL METERS

ATE models with the suffix DM indicates that the unit has digital meters in place of the analog meters. (NOTE: analog meters are no longer available.) Voltage meter accuracy is 0.1%; current meter accuracy is 3%. Refer to Figures 3, 4, 5 and 6 for front panel views of the quarter rack, half rack, three-quarter rack and full rack DM models. See Figures 7 and 8 for DM models.

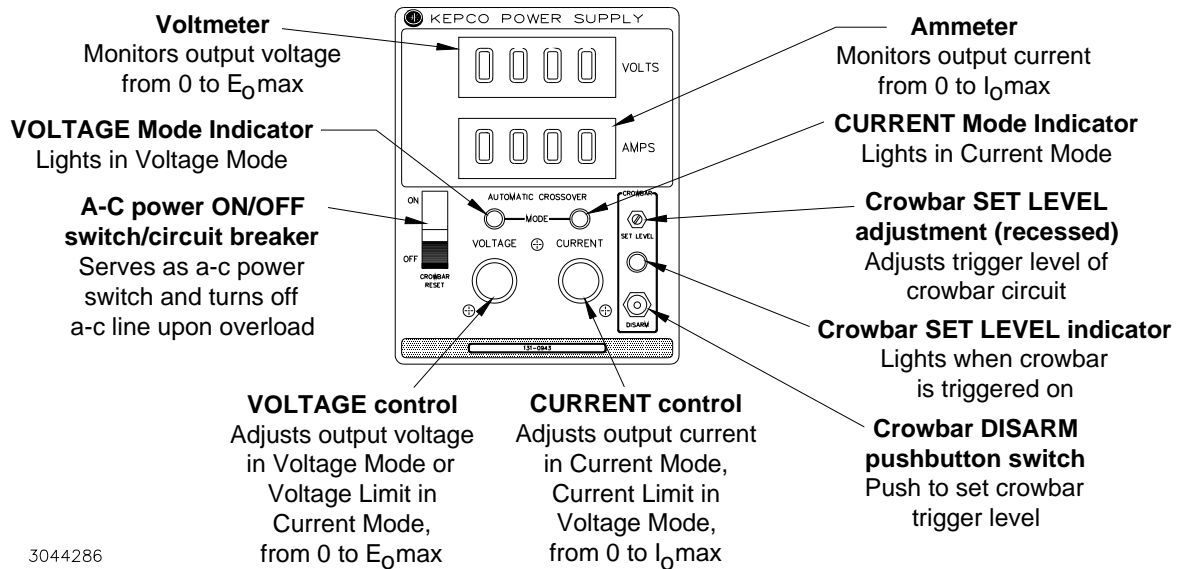

FIGURE 3. FRONT PANEL VIEW OF ATE QUARTER RACK DM (DIGITAL METER) MODELS

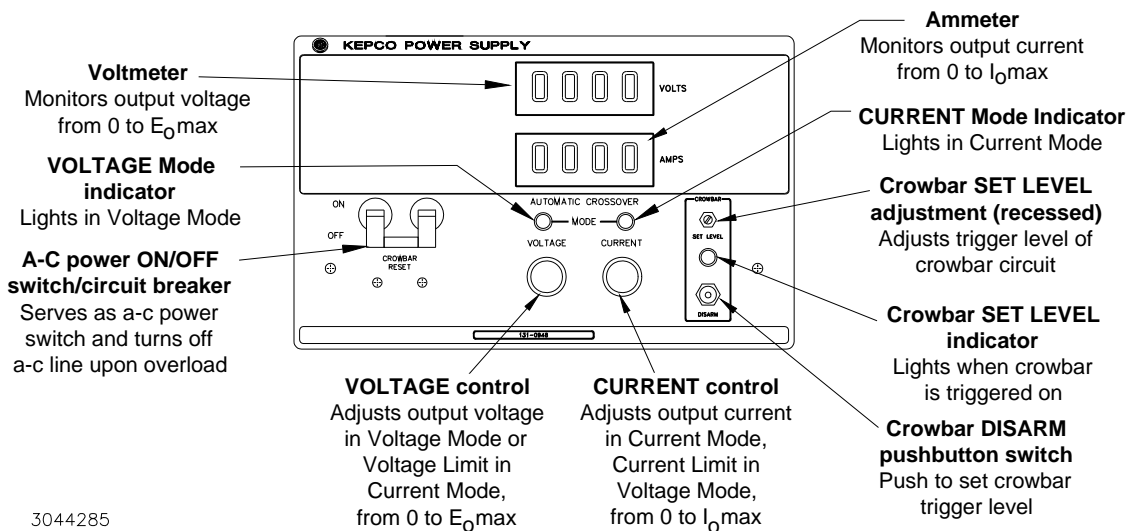

FIGURE 4. FRONT PANEL VIEW OF ATE 1/2 RACK DM (DIGITAL METER) MODELS

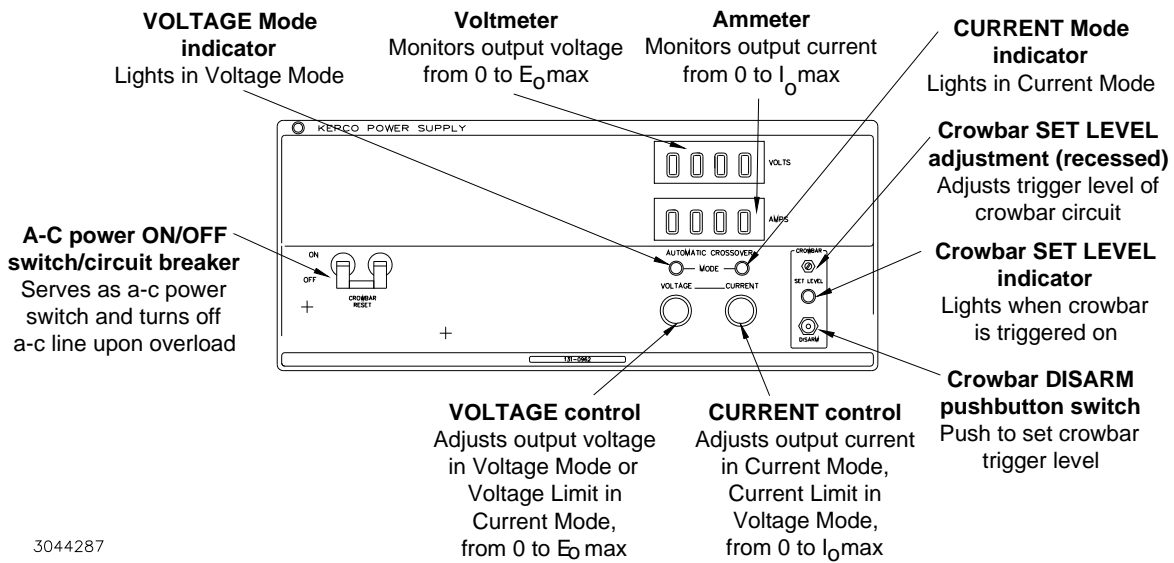

FIGURE 5. FRONT PANEL VIEW OF ATE 3/4 RACK DM (DIGITAL METER) MODELS

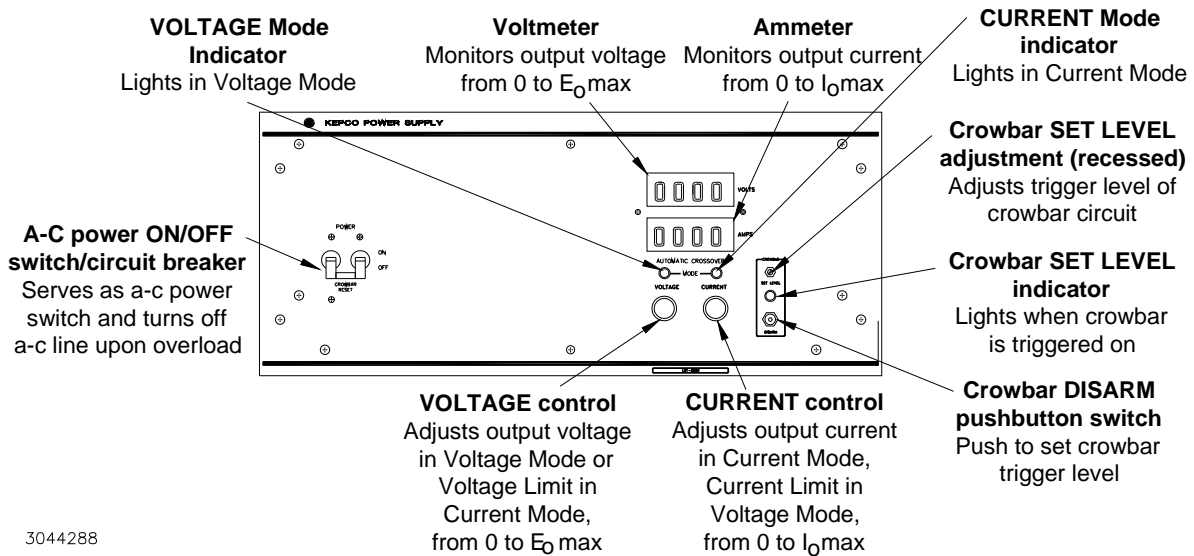

FIGURE 6. FRONT PANEL VIEW OF ATE FULL RACK DM (DIGITAL METER) MODELS



FIGURE 7. KEPCO ATE (DM) POWER SUPPLIES
(From Top: Size A, B, Size C, Size D, Size E)

1-9 SPECIFICATION, ELECTRICAL

a) AC INPUT SOURCE VOLTAGE:
 95 to 113V a-c or } Selectable,
 105 to 125V a-c or } See Section II
 190 to 226V a-c or } of this Manual
 210 to 250V a-c }

AC INPUT SOURCE CURRENT:
 (Worst Case, @ 113V a-c, 95–113V a-c tap, Full Load)

SIZE A	SIZE B	SIZE C	SIZE D	SIZE E
1.4 A	2.4 A	6.0 A	11.0 A	20.0 A

b) DC OUTPUT RATINGS: See Table 1-1.

Size "A" Quarter – Rack Models

MODEL	d-c OUTPUT RANGE		OUTPUT IMPEDANCE VOLTAGE MODE			OUTPUT IMPEDANCE CURRENT MODE		
	VOLTS	AMPS	SERIES RESISTANCE	SERIES INDUCTANCE SLOW	FAST	SHUNT* RESISTANCE	SHUNT CAPACITANCE SLOW	FAST
ATE 6-5DM	0-6	0-5	24 μΩ	0.5 μH	5 μH	12 kΩ	1,000 μF	1 μF
ATE 15-3DM	0-15	0-3	100 μΩ	0.5 μH	5 μH	30 kΩ	450 μF	0.4 μF
ATE 25-2DM	0-25	0-2	250 μΩ	1 μH	10 μH	50 kΩ	250 μF	0.25 μF
ATE 36-1.5DM	0-36	0-1.5	480 μΩ	1 μH	10 μH	72 kΩ	200 μF	0.2 μF
ATE 55-1DM	0-55	0-1	1.1 mΩ	2 μH	20 μH	110 kΩ	150 μF	0.15 μF
ATE 75-0.7DM	0-75	0-0.7	2.15 mΩ	2 μH	20 μH	150 kΩ	110 μF	0.1 μF
ATE 100-0.5DM	0-100	0-0.5	4 mΩ	4 μH	40 μH	200 kΩ	47 μF	0.05 μF
ATE 150-0.3DM	0-150	0-0.3	10 mΩ	4 μH	40 μH	300 kΩ	47 μF	0.02 μF



Size "B" Quarter – Rack Models

MODEL	d-c OUTPUT RANGE		OUTPUT IMPEDANCE VOLTAGE MODE			OUTPUT IMPEDANCE CURRENT MODE		
	VOLTS	AMPS	SERIES RESISTANCE	SERIES INDUCTANCE SLOW	FAST	SHUNT* RESISTANCE	SHUNT CAPACITANCE SLOW	FAST
ATE 6-10DM	0-6	0-10	12 μΩ	0.5 μH	5 μH	12 kΩ	1,800 μF	2 μF
ATE 15-6DM	0-15	0-6	50 μΩ	0.5 μH	5 μH	30 kΩ	1000 μF	0.8 μF
ATE 25-4DM	0-25	0-4	125 μΩ	1 μH	10 μH	50 kΩ	500 μF	0.5 μF
ATE 36-3DM	0-36	0-3	240 μΩ	1 μH	10 μH	72 kΩ	350 μF	0.4 μF
ATE 55-2DM	0-55	0-2	0.55 mΩ	2 μH	20 μH	110 kΩ	200 μF	0.3 μF
ATE 75-1.5DM	0-75	0-1.5	1 mΩ	2 μH	20 μH	150 kΩ	110 μF	0.2 μF
ATE 100-1DM	0-100	0-1	2 mΩ	4 μH	40 μH	200 kΩ	80 μF	0.1 μF
ATE 150-0.7DM	0-150	0-0.7	4 mΩ	4 μH	40 μH	300 kΩ	55 μF	0.04 μF



Size "C" Half – Rack Models

MODEL	d-c OUTPUT RANGE		OUTPUT IMPEDANCE VOLTAGE MODE			OUTPUT IMPEDANCE CURRENT MODE		
	VOLTS	AMPS	SERIES RESISTANCE	SERIES INDUCTANCE SLOW	FAST	SHUNT* RESISTANCE	SHUNT CAPACITANCE SLOW	FAST
ATE 6-25DM	0-6	0-25	4.8 μΩ	0.5 μH	5 μH	12 kΩ	11,000 μF	5 μF
ATE 15-15DM	0-15	0-15	20 μΩ	0.5 μH	5 μH	30 kΩ	5,800 μF	2 μF
ATE 25-10DM	0-25	0-10	50 μΩ	1 μH	10 μH	50 kΩ	2,900 μF	1.25 μF
ATE 36-8DM	0-36	0-8	90 μΩ	1 μH	10 μH	72 kΩ	2,400 μF	1 μF
ATE 55-5DM	0-55	0-5	0.22 mΩ	2 μH	20 μH	110 kΩ	1,400 μF	0.75 μF
ATE 75-3DM	0-75	0-3	0.5 mΩ	2 μH	20 μH	150 kΩ	850 μF	0.5 μF
ATE 100-2.5DM	0-100	0-2.5	0.8 mΩ	4 μH	40 μH	200 kΩ	375 μF	0.25 μF
ATE 150-1.5DM	0-150	0-1.5	2 mΩ	4 μH	40 μH	300 kΩ	275 μF	0.1 μF
ATE 325-0.8DM	0-325	0-0.8	8.1 mΩ	100 μH	1 mH	650 kΩ	180 μF	0.01 μF



Size "D" Three – Quarter – Rack Models

MODEL	d-c OUTPUT RANGE		OUTPUT IMPEDANCE VOLTAGE MODE			OUTPUT IMPEDANCE CURRENT MODE		
	VOLTS	AMPS	SERIES RESISTANCE	SERIES INDUCTANCE SLOW	FAST	SHUNT* RESISTANCE	SHUNT CAPACITANCE SLOW	FAST
ATE 6-50DM	0-6	0-50	2.4 μΩ	0.5 μH	5 μH	12 kΩ	12,000 μF	10 μF
ATE 15-25DM	0-15	0-25	12 μΩ	0.5 μH	5 μH	30 kΩ	8,000 μF	4 μF
ATE 25-20DM	0-25	0-20	25 μΩ	1 μH	10 μH	50 kΩ	5,800 μF	2.5 μF
ATE 36-15DM	0-36	0-15	48 μΩ	1 μH	10 μH	72 kΩ	4,900 μF	2 μF
ATE 55-10DM	0-55	0-10	0.11 mΩ	2 μH	20 μH	110 kΩ	2,900 μF	1.5 μF
ATE 75-8DM	0-75	0-8	0.19 mΩ	2 μH	20 μH	150 kΩ	1,200 μF	1 μF
ATE 100-5DM	0-100	0-5	0.4 mΩ	4 μH	40 μH	200 kΩ	600 μF	0.5 μF
ATE 150-3.5DM	0-150	0-3.5	0.86 mΩ	4 μH	40 μH	300 kΩ	440 μF	0.2 μF



Size "E" Full – Rack Models

MODEL	d-c OUTPUT RANGE		OUTPUT IMPEDANCE VOLTAGE MODE			OUTPUT IMPEDANCE CURRENT MODE		
	VOLTS	AMPS	SERIES RESISTANCE	SERIES INDUCTANCE SLOW	FAST	SHUNT* RESISTANCE	SHUNT CAPACITANCE SLOW	FAST
ATE 6-100DM	0-6	0-100	1.2 μΩ	0.5 μH	5 μH	12 kΩ	22,000 μF	15 μF
ATE 15-50DM	0-15	0-50	6 μΩ	0.5 μH	5 μH	30 kΩ	12,000 μF	6 μF
ATE 25-40DM	0-25	0-40	12.5 μΩ	1 μH	10 μH	50 kΩ	11,000 μF	4 μF
ATE 36-30DM	0-36	0-30	24 μΩ	1 μH	10 μH	72 kΩ	9,500 μF	3 μF
ATE 55-20DM	0-55	0-20	55 μΩ	2 μH	20 μH	110 kΩ	5,200 μF	2.25 μF
ATE 75-15DM	0-75	0-15	0.1 mΩ	2 μH	20 μH	150 kΩ	3,400 μF	1.5 μF
ATE 100-10DM	0-100	0-10	0.2 mΩ	4 μH	40 μH	200 kΩ	1,200 μF	0.75 μF
ATE 150-7DM	0-150	0-7	0.42 mΩ	4 μH	40 μH	300 kΩ	1,050 μF	0.3 μF



*Based on 0.5 mA load effect in FAST mode.

FIGURE 8. DC OUTPUT RATINGS, ATE (DM) POWER SUPPLIES

Conditions of Conformance

When this product is used in applications governed by the requirements of the EEC, the following restrictions and conditions apply:

1. For European applications, requiring compliance to the Low Voltage Directive, 2006/95/EC, this power supply is considered a component product, designed for "built in" applications. Because it is incomplete in construction, the end product enclosure must provide for compliance to any remaining electrical safety requirements and act as a fire enclosure. (EN61010-1:2010, Cl. 6, Cl. 7, Cl.8, and Cl. 9)
2. This power supply is designed for stationary installation, with mains power applied via a detachable power supply cord or via direct wiring to the source power terminal block.
3. This power supply is considered a Class 1 (earthed) product, and as such depends upon proper connection to protective earth for safety from electric shock. (EN61010-1 Cl. 6.5.5)
4. This power supply is intended for use as part of equipment meant for test, measurement and laboratory use, and is designed to operate from single phase, three wire power systems. This equipment must be installed within a suitably wired equipment rack, utilizing a three wire (grounded) mains connection. See wiring section of this manual for complete electrical wiring instructions. (EN61010-1 Cl. 6.5.5 and Cl.6.10.1)
5. For European applications requiring compliance with the RoHS 2 directive, 2011/65/EU, this power supply is designed for scientific research and technological development, and is excluded from the scope of the directive [2011, 65/EU, Article 2 (4) (j)].
6. This power supply has secondary output circuits that are considered hazardous, and which exceed 240 VA at a potential of 2V or more.
7. The output wiring terminals of this power supply has not been evaluated for field wiring and, therefore, must be properly configured by the end product manufacturer prior to use.
8. This power supply employs a supplementary circuit protector in the form of a circuit breaker mounted on the front panel. This circuit breaker protects the power supply itself from damage in the event of a fault condition. For complete circuit protection of the end product, as well as the building wiring, it is required that a primary circuit protection device be fitted to the branch circuit wiring. (EN61010-1:2010, Cl. 9.6)
9. Hazardous voltages are present within this power supply during normal operation. All operator adjustments to the product are made via externally accessible switches, controls and signal lines as specified within the product operating instructions. There are no user or operator serviceable parts within the product enclosure. Refer all servicing to qualified and trained Kepco service technicians.

SAFETY INSTRUCTIONS

1. Installation, Operation and Service Precautions

This product is designed for use in accordance with EN 61010-1 and UL 3101 for Installation Category 2, Pollution Degree 2. Hazardous voltages are present within this product during normal operation. The product should never be operated with the cover removed unless equivalent protection of the operator from accidental contact with hazardous internal voltages is provided:



There are no operator serviceable parts or adjustments within the product enclosure. Refer all servicing to trained service technician.



Source power must be removed from the product prior to performing any servicing.



This product is factory-wired for the nominal a-c mains voltage indicated on the rating nameplate located adjacent to the source power connection on the product's rear panel. To reconfigure the product input for other nominal mains voltages as listed herein, the product must be modified by a trained service technician.

2. Grounding

This product is a Class 1 device which utilizes protective earthing to ensure operator safety.



The PROTECTIVE EARTHING CONDUCTOR TERMINAL must be properly connected prior to application of source power to the product (see instructions on installation herein) in order to ensure safety from electric shock.



PROTECTIVE EARTHING CONDUCTOR TERMINAL - This symbol indicates the point on the product to which the protective earthing conductor must be attached.



EARTH (GROUND) TERMINAL - This symbol is used to indicate a point which is connected to the PROTECTIVE EARTHING TERMINAL. The component installer/ assembler must ensure that this point is connected to the PROTECTIVE EARTHING TERMINAL.

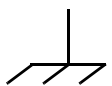

CHASSIS TERMINAL - This symbol indicates frame (chassis) connection, which is supplied as a point of convenience for performance purposes (see instructions on grounding herein). This is not to be confused with the protective earthing point, and may not be used in place of it.

3. Electric Shock Hazards

This product outputs hazardous voltage and energy levels as a function of normal operation. Operators must be trained in its use and exercise caution as well as common sense during use to prevent accidental shock.



This symbol appears adjacent to any external terminals at which hazardous voltage levels as high as 500V d-c may exist in the course of normal or single fault conditions.



This symbol appears adjacent to any external terminals at which hazardous voltage levels in excess of 500V d-c may exist in the course of normal or single fault conditions.

TABLE OF CONTENTS

PARAGRAPH		PAGE
SECTION I – INSTRUCTION		
1-1	Scope of Manual	1-1
1-3	General Description	1-1
1-9	Specifications, Electrical.	1-2
1-10	Miscellaneous Features	1-5/1-6
1-11	Mechanical Specifications	1-5/1-6
1-12	Accessories.	1-5/1-6
1-14	Options	1-5/1-6
 SECTION II – INSTALLATION		
2-1	Unpacking and Inspection.	2-1
2-3	Terminations	2-1
2-4	A-C Input Requirements.	2-4
2-6	Cooling	2-4
2-8	Preliminary Check-Out	2-4
2-10	Installation.	2-5
2-13	Grounding	2-5
2-14	Fast Mode Conversion of the ATE Power Supply.	2-6
 SECTION III – OPERATION		
3-1	General	3-1
3-3	Safety Grounding	3-1
3-6	D-C Output Grounding.	3-1
3-12	Power Supply/Load Interface	3-2
3-16	Load Connection, General.	3-3
3-19	Load Connection, Method I (Local Error Sensing)	3-4
3-21	Load Connection, Method II (Remote Error Sensing)	3-4
3-24	Load Connections, Method III	3-5
3-27	Standard Voltage Mode Operation (Front Panel Control)	3-5
3-29	Standard Current Mode Operation (Front Panel Control)	3-6
3-31	Overvoltage Crowbar, Setup and Check	3-6
3-34	Introduction to Remote Control of the ATE Output	3-7
3-37	Programming the Voltage Control Channel.	3-7
3-41	Output Control with an External 0–10 Volt D-C Control Signal.	3-7
3-45	Voltage Control with a Two-Terminal Resistance.	3-8
3-51	Voltage Control with a High Impedance Control Source	3-10
3-57	Programming the Current Control Channel.	3-12
3-60	Output Current Control with an External Control Signal.	3-12
3-64	Output Current Control with a Two-Terminal Resistance	3-13
3-70	Programming the Overvoltage Protector.	3-15
3-72	Remote Crowbar Level Control with an External 0–10 Volt D-C 1 mA Signal	3-15
3-75	Automatic (Tracking) Control of the Crowbar Level	3-16
3-78	Programming Output Voltage and Output Current Simultaneously	3-17
3-84	The Use of the "EXT. CURRENT COMPARISON AMPLIFIER" for General Feedback Control	3-19
3-91	Multiple Power Supply and Systems Operation	3-20
3-94	Series Operation of ATE Power Supplies	3-21
3-103	Parallel Operation of ATE Power Supplies	3-25
3-115	Programming With Reference to the NEGATIVE Power Supply Output.	3-32
3-121	Application of Isolated Flag Signals	3-34

LIST OF ILLUSTRATIONS

FIGURE		PAGE
1-1	Kepeco ATE Power Supplies	v/vi
1-2	Mechanical Outline Drawing	1-7/1-8
2-1	Location of Internal Controls	2-1
2-2	Controls and Terminations (Front)	2-2
2-3	Terminations (Rear)	2-3
2-4	A-C Input Source Selection	2-4
2-5	Location of the Internal Signal Ground	2-5
2-6	Required Steps for "Slow Mode/Fast Mode" Conversion	2-6
3-1	Typical Output Impedance Curve	3-2
3-2	Standard Jumper Link Connections	3-3
3-3	Load Connection, Method I	3-4
3-4	Load Connection, Method II	3-4
3-5	Load Connection, Method III	3-5
3-6	Output Voltage Control With an External (0–10 Volt, 1 mA) D-C Control Signal	3-8
3-7	Two-Terminal Resistance Programming of the Voltage Channel Using PREAMP "A" and the Internal Reference Source	3-8
3-8	Connections for Voltage Control With a Two-Terminals Resistance	3-9
3-9	Using PREAMP "A" to Generate the 0–10 Volt @ 1 mA Control Potential from a High Impedance Source	3-10
3-10	Connections for Voltage Control With a High Impedance Input Source	3-11
3-11	Connections for Output Current Control With a 0–1 Volt Control Signal (Kepeco SN Programmer)	3-12
3-12	Two-Terminal Resistance Programming of the Current Channel Using PREAMP "B" and the Internal Reference Source	3-13
3-13	Connections for Output Current Control With a Two-Terminal Resistance	3-14
3-14	Remote Crowbar Level Control With an External Signal Source	3-15
3-15	Connections for Simultaneously Programming the Output Voltage and the Crowbar Level (Automatic Tracking)	3-16
3-16	Connections for Simultaneous Control of the Output Voltage/Output Current	3-17
3-17	Illumination Control Circuit With the ATE Power Supply	3-19
3-18	Connections for Illumination Control, Using the EXT. CURRENT COMPARISON AMPLIFIER	3-20
3-19	Multiple Power Supply Fault Detection Loop	3-21
3-20	Automatic Series Connections	3-22
3-21	Developing the Drive for Master/Slave Series Connection, ATE Power Supplies With More Than 6 Volt Output Voltage	3-23
3-22	Master Slave Series Connection, ATE Power Supplies With > 6 Volt Output Voltage	3-24
3-23	Developing the Driver for Master/Slave Series Connection, for 6 Volt ATE Supplies	3-25
3-24	"Automatic" Parallel Operation, Output Graph	3-26
3-25	Connections for Automatic Parallel Operation	3-27
3-27	Location of the Overvoltage Sensing Lead Disconnect	3-30
3-28	Redundant Parallel Connection	3-31
3-29	Programming With Reference to the NEGATIVE Output of the ATE	3-32
3-30	Connections for Programming With Reference to the NEGATIVE Output of the ATE	3-33
3-31	Isolated Flag Signal Outputs	3-34
3-32	ATE 1/2 Rack, 3/4 Rack and Full Rack, Simplified Schematic Diagram	3-35
3-33	Programmable Overvoltage Protector and Crowbar Circuit, Simplified Schematic Diagram	3-37

LIST OF TABLES

TABLE		PAGE
1-1	D-C Output Ratings, ATE Power Supplies1-2
1-2	Output Effects, Offset Variations and Ripple Specifications1-3
2-1	Internal Controls and Their Functions.2-1
2-2	Controls and Terminations, Front Panel.2-2
2-3	Rear Terminations.2-3

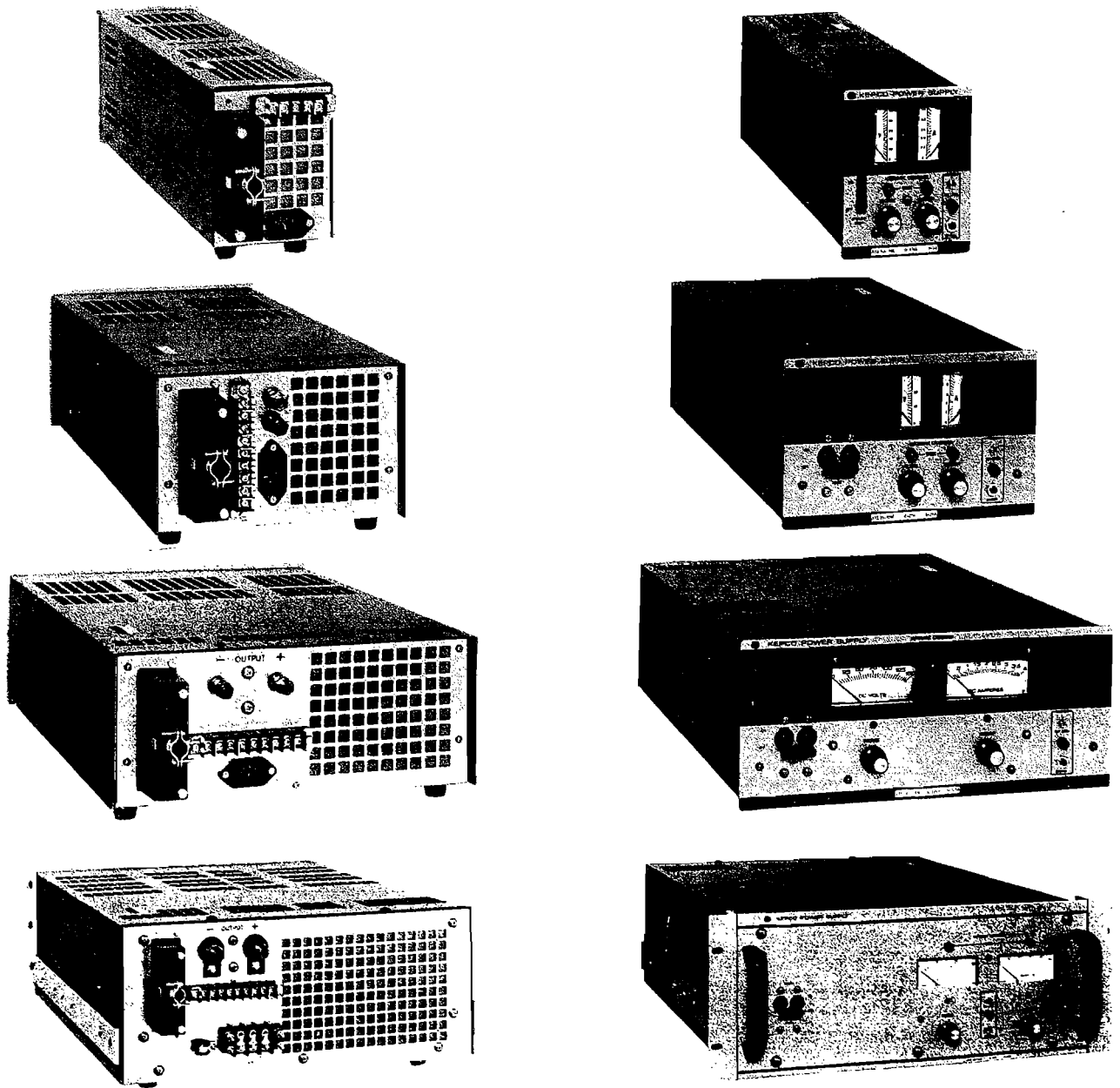

FIG. 1-1 KEPCO ATE POWER SUPPLIES.
(From Top: Size A, B; Size C; Size D; Size E).

SECTION I – INTRODUCTION

1-1 SCOPE OF MANUAL

- 1-2 This manual contains instructions for the installation, and operation of the 1/4-rack "ATE" series of voltage and current stabilized d-c power supplies, both M suffix (analog meter) and DM suffix (digital meter), manufactured by Kepco, Inc., Flushing, New York, U.S.A.

1-3 GENERAL DESCRIPTION

- 1-4 The Kepco ATE with programmable overvoltage protector is a precision stabilized power supply which can deliver either stabilized output voltage or current. The prevailing operating mode is indicated by LED mode indicators at the front panel. Operating mode crossover is automatic and may be monitored remotely by means of a flag signal, available at the rear programming connector. The power supply features "full range" output control by means of 10-turn, high resolution front panel potentiometers. A pair of front panel meters constantly monitor the output voltage and output current. This power supply has a linear and fully dissipative NPN pass transistor section driven by high-gain, integrated circuit amplifiers. The output of the power supply is fully programmable. All necessary input terminals are provided on a programming connector at the rear of the chassis. Terminals are also provided for remote error sensing, as well as for the connection of the output capacitor directly at the load.
- 1-5 The ATE power supply features user-selectable "slow" or "fast" operating modes. Slow mode operation is recommended for applications demanding a constant voltage source. Fast mode operation is best if the output voltage must change rapidly, either in response to an external programming signal or, if the ATE is used as a current stabilizer, as a reaction to changing load resistance.
- 1-6 **The ATE power supply is delivered for "slow mode" operation. See Section II, par. 2-4 for converting the ATE power supply to "fast mode" operation.**
- 1-7 An overvoltage protection circuit, continuously adjustable as well as remotely programmable, is a built-in feature. The trigger point of the overvoltage protector may be set (or checked) under actual operating conditions by the front panel accessible setup controls (refer to Section II of this manual).
- 1-8 ATE power supplies are built in several mechanical sizes according to their approximate output power ratings:

SIZE	PACKAGE	APPROX. OUTPUT POWER
"A"	QUARTER-RACK MODELS	50 WATT
"B"	QUARTER-RACK MODELS	100 WATT
"C"	HALF-RACK MODELS	250 WATT
"D"	THREE-QUARTER RACK MODELS	500 WATT
"E"	FULL-RACK MODELS	1000 WATT

Power transistors and drivers on all ATE designs are mounted onto highly efficient, patented heat sink assemblies which are cooled by low-noise fans. The ATE main chassis assemblies, as well as the wrap-around covers, are constructed from cold-rolled steel. The front panels are made from aluminum (refer to the "Mechanical Outline Drawing", FIG. 1-2).

1-9 SPECIFICATION, ELECTRICAL

a) AC INPUT SOURCE VOLTAGE:

95 to 113V a-c or
105 to 125V a-c or
190 to 226V a-c or
210 to 250V a-c

Selectable,
See Section II
of this Manual

AC INPUT SOURCE CURRENT:

(Worst Case, @ 113V a-c, 95–113V a-c tap, Full Load)

SIZE A	SIZE B	SIZE C	SIZE D	SIZE E
1.4 A	2.4 A	6.0 A	11.0 A	20.0 A

b) DC OUTPUT RATINGS: See Table 1-1.

Size "A" Quarter - Rack Models

MODEL	d-c OUTPUT RANGE		OUTPUT IMPEDANCE VOLTAGE MODE			OUTPUT IMPEDANCE CURRENT MODE		
	VOLTS	AMPS	SERIES RESISTANCE	SERIES INDUCTANCE SLOW	FAST	SHUNT* RESISTANCE	SHUNT CAPACITANCE SLOW	FAST
ATE 6-5M	0-6	0-5	24 μΩ	0.5 μH	5 μH	12 kΩ	1,000 μF	1 μF
ATE 15-3M	0-15	0-3	100 μΩ	0.5 μH	5 μH	30 kΩ	450 μF	0.4 μF
ATE 25-2M	0-25	0-2	250 μΩ	1 μH	10 μH	50 kΩ	250 μF	0.25 μF
ATE 36-1.5M	0-36	0-1.5	480 μΩ	1 μH	10 μH	72 kΩ	200 μF	0.2 μF
ATE 55-1M	0-55	0-1	1.1 mΩ	2 μH	20 μH	110 kΩ	150 μF	0.15 μF
ATE 75-0.7M	0-75	0-0.7	2.15 mΩ	2 μH	20 μH	150 kΩ	110 μF	0.1 μF
ATE 100-0.5M	0-100	0-0.5	4 mΩ	4 μH	40 μH	200 kΩ	50 μF	0.05 μF
ATE 150-0.3M	0-150	0-0.3	10 mΩ	4 μH	40 μH	300 kΩ	55 μF	0.02 μF

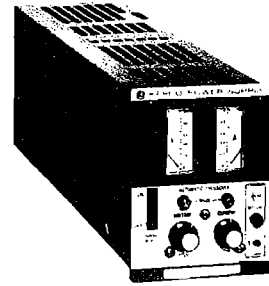

Size "B" Quarter - Rack Models

MODEL	d-c OUTPUT RANGE		OUTPUT IMPEDANCE VOLTAGE MODE			OUTPUT IMPEDANCE CURRENT MODE		
	VOLTS	AMPS	SERIES RESISTANCE	SERIES INDUCTANCE SLOW	FAST	SHUNT* RESISTANCE	SHUNT CAPACITANCE SLOW	FAST
ATE 6-10M	0-6	0-10	12 μΩ	0.5 μH	5 μH	12 kΩ	1,800 μF	2 μF
ATE 15-6M	0-15	0-6	50 μΩ	0.5 μH	5 μH	30 kΩ	1000 μF	0.8 μF
ATE 25-4M	0-25	0-4	125 μΩ	1 μH	10 μH	50 kΩ	500 μF	0.5 μF
ATE 36-3M	0-36	0-3	240 μΩ	1 μH	10 μH	72 kΩ	350 μF	0.4 μF
ATE 55-2M	0-55	0-2	0.55 mΩ	2 μH	20 μH	110 kΩ	200 μF	0.3 μF
ATE 75-1.5M	0-75	0-1.5	1 mΩ	2 μH	20 μH	150 kΩ	110 μF	0.2 μF
ATE 100-1M	0-100	0-1	2 mΩ	4 μH	40 μH	200 kΩ	80 μF	0.1 μF
ATE 150-0.7M	0-150	0-0.7	4 mΩ	4 μH	40 μH	300 kΩ	55 μF	0.04 μF

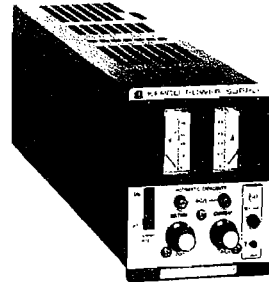

Size "C" Half - Rack Models

MODEL	d-c OUTPUT RANGE		OUTPUT IMPEDANCE VOLTAGE MODE			OUTPUT IMPEDANCE CURRENT MODE		
	VOLTS	AMPS	SERIES RESISTANCE	SERIES INDUCTANCE SLOW	FAST	SHUNT* RESISTANCE	SHUNT CAPACITANCE SLOW	FAST
ATE 6-25M	0-6	0-25	4.8 μΩ	0.5 μH	5 μH	12 kΩ	11,000 μF	5 μF
ATE 15-15M	0-15	0-15	20 μΩ	0.5 μH	5 μH	30 kΩ	5,800 μF	2 μF
ATE 25-10M	0-25	0-10	50 μΩ	1 μH	10 μH	50 kΩ	2,900 μF	1.25 μF
ATE 36-8M	0-36	0-8	90 μΩ	1 μH	10 μH	72 kΩ	2,400 μF	1 μF
ATE 55-5M	0-55	0-5	0.22 mΩ	2 μH	20 μH	110 kΩ	1,400 μF	0.75 μF
ATE 75-3M	0-75	0-3	0.5 mΩ	2 μH	20 μH	150 kΩ	850 μF	0.5 μF
ATE 100-2.5M	0-100	0-2.5	0.8 mΩ	4 μH	40 μH	200 kΩ	375 μF	0.25 μF
ATE 150-1.5M	0-150	0-1.5	2 mΩ	4 μH	40 μH	300 kΩ	275 μF	0.1 μF
ATE 325-0.8M	0-325	0-0.8	8.1 mΩ	100 μH	1 mH	650 kΩ	180 μF	0.01 μF



Size "D" Three - Quarter - Rack Models

MODEL	d-c OUTPUT RANGE		OUTPUT IMPEDANCE VOLTAGE MODE			OUTPUT IMPEDANCE CURRENT MODE		
	VOLTS	AMPS	SERIES RESISTANCE	SERIES INDUCTANCE SLOW	FAST	SHUNT* RESISTANCE	SHUNT CAPACITANCE SLOW	FAST
ATE 6-50M	0-6	0-50	2.4 μΩ	0.5 μH	5 μH	12 kΩ	12,000 μF	10 μF
ATE 15-25M	0-15	0-25	12 μΩ	0.5 μH	5 μH	30 kΩ	8,000 μF	4 μF
ATE 25-20M	0-25	0-20	25 μΩ	1 μH	10 μH	50 kΩ	5,800 μF	2.5 μF
ATE 36-15M	0-36	0-15	48 μΩ	1 μH	10 μH	72 kΩ	4,900 μF	2 μF
ATE 55-10M	0-55	0-10	0.11 mΩ	2 μH	20 μH	110 kΩ	2,900 μF	1.5 μF
ATE 75-8M	0-75	0-8	0.19 mΩ	2 μH	20 μH	150 kΩ	1,200 μF	1 μF
ATE 100-5M	0-100	0-5	0.4 mΩ	4 μH	40 μH	200 kΩ	600 μF	0.5 μF
ATE 150-3.5M	0-150	0-3.5	0.86 mΩ	4 μH	40 μH	300 kΩ	440 μF	0.2 μF



Size "E" Full - Rack Models

MODEL	d-c OUTPUT RANGE		OUTPUT IMPEDANCE VOLTAGE MODE			OUTPUT IMPEDANCE CURRENT MODE		
	VOLTS	AMPS	SERIES RESISTANCE	SERIES INDUCTANCE SLOW	FAST	SHUNT* RESISTANCE	SHUNT CAPACITANCE SLOW	FAST
ATE 6-100M	0-6	0-100	1.2 μΩ	0.5 μH	5 μH	12 kΩ	22,000 μF	15 μF
ATE 15-50M	0-15	0-50	6 μΩ	0.5 μH	5 μH	30 kΩ	12,000 μF	6 μF
ATE 25-40M	0-25	0-40	12.5 μΩ	1 μH	10 μH	50 kΩ	11,000 μF	4 μF
ATE 36-30M	0-36	0-30	24 μΩ	1 μH	10 μH	72 kΩ	9,500 μF	3 μF
ATE 55-20M	0-55	0-20	55 μΩ	2 μH	20 μH	110 kΩ	5,200 μF	2.25 μF
ATE 75-15M	0-75	0-15	0.1 mΩ	2 μH	20 μH	150 kΩ	3,400 μF	1.5 μF
ATE 100-10M	0-100	0-10	0.2 mΩ	4 μH	40 μH	200 kΩ	1,200 μF	0.75 μF
ATE 150-7M	0-150	0-7	0.42 mΩ	4 μH	40 μH	300 kΩ	1,050 μF	0.3 μF

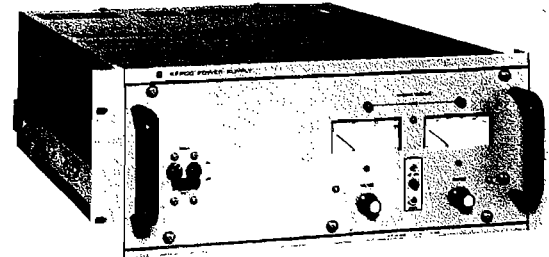

*Based on 0.5 mA load effect in FAST mode.

c) OUTPUT EFFECTS, OFFSETS AND RIPPLE SPECIFICATIONS: See Table 1-2.

INFLUENCE QUANTITY	OUTPUT EFFECTS VOLTAGE MODE		OUTPUT EFFECTS CURRENT MODE		OFFSETS ⁽⁴⁾	
	Typical	Maximum	Typical	Maximum	ΔE_{iO}	ΔI_{iO}
SOURCE VOLTAGE (min.-max.):	<0.0005% E_O max.	0.001% E_O max.	<0.002% I_O max.	0.005% I_O max.	<1 μ V	<1 nA
LOAD (no load-full load):	<0.001% E_O max.	0.002% E_O max.	<0.5 mA ⁽¹⁾	1 mA ⁽¹⁾	<1 μ V	<1 nA
TIME (8-hour drift):	<0.005% E_O max.	0.01% E_O max.	<0.01% I_O max.	0.02% I_O max.	<20 μ V	<1 nA
TEMPERATURE, per °C:	<0.005% E_O max.	0.01% E_O max.	<0.01% I_O max.	0.02% I_O max.	<20 μ V	<2 nA
RIPPLE AND NOISE⁽²⁾ rms:						
(Slow Mode) p-p: ⁽³⁾	<0.1 mV	0.3 mV	<0.01% I_O max.	0.03% I_O max.	—	—
	<1 mV	3 mV	<0.1% I_O max.	0.3% I_O max.	—	—
RIPPLE AND NOISE⁽²⁾ rms:						
(Fast Mode) p-p: ⁽³⁾	<1 mV	3 mV ⁽⁵⁾	<0.01% I_O max.	0.03% I_O max.	—	—
	<10 mV	30 mV ⁽⁵⁾	<0.1% I_O max.	0.3% I_O max.	—	—

- (1) For models with output current rating of 50A and higher, the load effect is 2 mA typical and 5 mA maximum. In slow mode, the leakage current through the output capacitor adds approximately 0-6 mA to the current mode load effect.
- (2) One terminal must be grounded for this measurement, or connected so that common mode current does not flow through the load or, in current mode, through the current sensing resistor.
- (3) Peak-to-peak ripple is measured over a 20 Hz to 10 MHz bandwidth.
- (4) Pre-amplifier offsets. The pre-amplifier offsets are given for the calculation of the output effects of pre-amplifiers (A, B) if either of these amplifiers is used for operational programming. In this case, the value of the external feedback and input resistors, the amplifier offsets and the reference voltage variations are combined in the "Error Equation", which represents the "worst case" output effects for the application at hand:

$$\Delta E_O (\text{preamp}) = \Delta E_{\text{ref}} (R_f/R_i) + \Delta E_{iO} (1 + R_f/R_i) + \Delta I_{iO} R_f.$$

- where: ΔE_O (preamp) = Total Preamp Output Voltage Change.
 ΔE_{ref} = Change in the Voltage Reference.
 ΔE_{iO} = Change in Offset Voltage.
 ΔI_{iO} = Change in Offset Current.
 R_f = External Feedback Resistor.
 R_i = External Input Resistor.

NOTE 1: Variations in the value of the feedback and input resistors are considered secondary effects in the error equation.

NOTE 2: In the Voltage Mode of operation, the calculated preamp output effect, ΔE_O (preamp), must be multiplied by the (fixed) gain of the ATE voltage channel to find the total output effect on the output voltage of the ATE power supply. The (fixed) gain of the ATE voltage channel is given by: $\text{GAIN} = E_O \text{ max}/10$, where "E_O max." is the maximum rated output voltage of each ATE model. In the Current Mode of operation, the effect of the pre-amplifier offsets on the total output current may be expressed as a percentage of I_O max. by the equation:

$$\Delta I_O (\%) = \frac{\Delta E_O (\text{preamp})}{1 \text{ Volt}} \times 100\%$$

- (5) For Kepco Model ATE 325-0.8M, the maximum output ripple and noise is 10mV rms and 50mV p-p.

TABLE 1-2 OUTPUT EFFECTS, OFFSET VARIATIONS AND RIPPLE SPECIFICATIONS.

- d) OUTPUT RANGES: (See Table 1-1 for specific ratings of each model)
- 1) VOLTAGE MODE: 0-100% of rated voltage.
 - 2) CURRENT MODE: 0-100% of rated current. Useable range limited to approximately 1% to 100%. The maximum current is factory set to 105% of the rated output current.
- e) OPERATING TEMPERATURE RANGE: 0 °C to 65 °C. No derating to 55 °C, derate 10% of listed maximum output current values in Table 1-1 for operation to 65 °C ambient temperature.
- f) STORAGE TEMPERATURE RANGE: (-)40 °C to 85 °C.
- g) COOLING: High efficiency, single bearing fans, permanently lubricated, with special low-noise non-metallic blades.

h) ISOLATION: A maximum of 500 volts (d-c or p-p) can be connected between chassis and either output terminal. The common-mode current from either output terminal to ground is less than $5\mu\text{A}$ (rms) or less than $50\mu\text{A}$ (p-p) at 115V a-c 60 Hz.

i) DYNAMIC SPECIFICATIONS

1) VOLTAGE RECOVERY FOR A STEP-LOAD CURRENT:

The time required for the stabilized output voltage to recover to within 10 mV of the output voltage setting, for a 10 to 100% step in rated load current is typically less than $50\mu\text{sec.}$, $100\mu\text{sec.}$ maximum.

2) CURRENT RECOVERY FOR STEP-LOAD VOLTAGE:

The stabilized output current recovers from a step in load (compliance) voltage with an exponential response, the time constant of which is determined by the load resistance and the tabulated output capacitance (See Table 1-1).

3) PROGRAMMING SPEED:

The speed with which the power supply output responds to external programming signals is determined by:

- 1) The PROGRAMMING TIME CONSTANT (τ), given in the "slow" mode by either the load resistance (R_L) and the value of the output capacitor (C_o , see Table 1-1): $\tau = R_L C_o$, or by the FEEDBACK TIME CONSTANT, given by the product of the feedback capacitor and the feedback resistor: $\tau = R_f C_f$, whichever is greater. In the "fast" mode, the PROGRAMMING TIME CONSTANT and bandwidth (-3dB) for the Voltage Control Channel is shown in the table:

Output Voltage Ratings	Bandwidth (-3dB) KHz		Programming Time Constant (μsec)	
	Typ.	Min.	Typ.	Max.
6V	23.0	16.0	7.0	10.0
15V	20.0	10.6	8.0	15.0
25V	11.5	8.0	14.0	20.0
36V	8.0	6.4	20.0	25.0
55V	4.8	4.0	33.0	40.0
75V	4.3	3.5	37.0	45.0
100V	2.7	2.5	60.0	65.0
150V	1.8	1.7	88.0	95.0
325V	1.5	0.94	110.0	170.0

For the Current Control Channel, the PROGRAMMING TIME CONSTANT is $25\mu\text{sec.}$ typical, $50\mu\text{sec.}$ maximum. ($80\mu\text{sec.}$ for the ATE 325-0.8M).

- 2) The MAXIMUM RATE OF CHANGE that the power supply output can respond to is given by the setting of the power supply's current control setting (I_{LIM}), divided by the ATE output capacitor (C_o , see Table 1-1):

$$\text{MAXIMUM RATE OF CHANGE} = I_{LIM}/C_o$$

k) OVERVOLTAGE CROWBAR SPECIFICATIONS:

- 1) TRIGGERING TIME: $<50\mu\text{sec.}$ slow mode, $<500\mu\text{sec.}$ fast mode.
- 2) SETTING RANGE: 1.6% or 3V (whichever is greater) minimum, to 110% of the maximum rated output voltage for each model.
- 3) THRESHOLD: Minimum 0.5 volts, or 2% $E_{o\text{ max.}}$, whichever is greater.
- 4) TEMPERATURE COEFFICIENT: $<0.02\%$ of $E_{o\text{ max.}}$ per $^{\circ}\text{C}$.

1-10 MISCELLANEOUS FEATURES

a) CONTROL/PROGRAMMING

- 1) **VOLTAGE CHANNEL:** Output voltage is controlled continuously throughout the range by a panel-mounted, 10-turn rheostat. External control can be exercised by resistance or by a control voltage (See Section III).
 - 2) **CURRENT CHANNEL (INTERNAL):** Output current is controlled continuously throughout the range by a panel-mounted, 10-turn potentiometer. External control can be exercised by resistance or by a control voltage (See Section III). When controlling the external current channel, the power supply's panel-mounted current control serves as an adjustable maximum current limit.
 - 3) **CURRENT CHANNEL (EXTERNAL):** Output current may be controlled by means of a separate current channel, applying a 0 to 1V d-c control signal at the REAR PROGRAMMING CONNECTOR, for control over the rated current range. This same channel, properly programmed, may control the output of the power supply responding to control and feedback voltages from temperature or pressure sensors, chemical reactions and the like (See Section III).
 - 4) **OVERVOLTAGE PROTECTOR.** The crowbar level may be controlled locally by the provided CROWBAR LEVEL control at the front panel. Remote control of the crowbar level can be exercised by connecting a 0-10 volt control source to the REAR PROGRAMMING CONNECTOR. Automatic tracking of the crowbar level with the output voltage level may be achieved by means of the simultaneous connection of the voltage channel programming source to the tracking input.
- b) **MODE FLAG:** A pair of panel LED indicators operate to indicate whether the voltage channel or the internally-sensed current channels have control of the output. In addition, an isolated flag signal is provided through an opto-isolator at the rear programming connector.
- c) **REMOTE ERROR SENSING:** Separate voltage-sensing terminals permit 4-wire connections to a load. Will compensate for static load effects up to 0.5V per lead. An additional 1 Volt output voltage, beyond the nominal voltage rating of each ATE model, is provided for this purpose.
- d) **REFERENCE SUPPLIES:** Two dual reference sources are available at the REAR PROGRAMMING CONNECTOR: $\pm 6.2V$ d-c @ 1 mA and $\pm 15V$ d-c @ 10 mA.
- e) **CURRENT SENSING AMPLIFIER:** The output of the current sensing amplifier is available on the rear programming connector. It provides a voltage analog of the output current. The range of the analog output is 0 to +1V, corresponding to output currents of 0 to 100% (respectively).

1-11 MECHANICAL SPECIFICATIONS

- a) Refer to the "Mechanical Outline Drawing", FIG. 1-2 .

1-12 ACCESSORIES

- 1-13 ATE power supplies are supplied with one Model PC-12 Programming Connector, mounted and wired for front panel output control. Additional connectors are optional and may be ordered as MODEL PC-12 (unwired). ATE models smaller than full-rack size can be rack mounted, using one of several Kepco Rack Adapters:

NOTE: ALL KEPKO RACK ADAPTERS FIT STANDARD EIA RACK DIMENSIONS. THEY ARE DRILLED FOR STANDARD CHASSIS SLIDES AND ARE PROVIDED WITH SLIDE SUPPORT BRACKETS.

- a) **RACK ADAPTER, KEPKO MODEL RA-24.** For all Kepco quarter-rack, half-rack and three quarter-rack models, or a mixture of them. Filler panels to cover empty slots, if the adapter is not used to its full capacity, are available.
- b) **RACK ADAPTER, KEPKO MODEL RA-32.** For (two) Kepco quarter-rack models or (one) half-rack model. Has additional space for (three) one-sixth rack modular Kepco units. Filler panels to cover empty slots, if the adapter is not used to its full capacity, are available.
- c) **RACK ADAPTER, KEPKO MODEL RA-37. For Kepco ATE models only.** Accepts quarter-rack, half-rack or three quarter-rack ATE models or a mixture of them. The model RA-37 can be used without filler support brackets when fully loaded.

1-14 OPTIONS

- 1-15 **MODEL SUFFIX "DM"** This option replaces the analog voltmeter and ammeter on the front panel with digital LCD meters.

- 1-16 **MODEL SUFFIX "L"** This option replaces the front panel knobs with locking-type screwdriver-adjustable controls. It may be applied to either "M" or "DM" models.

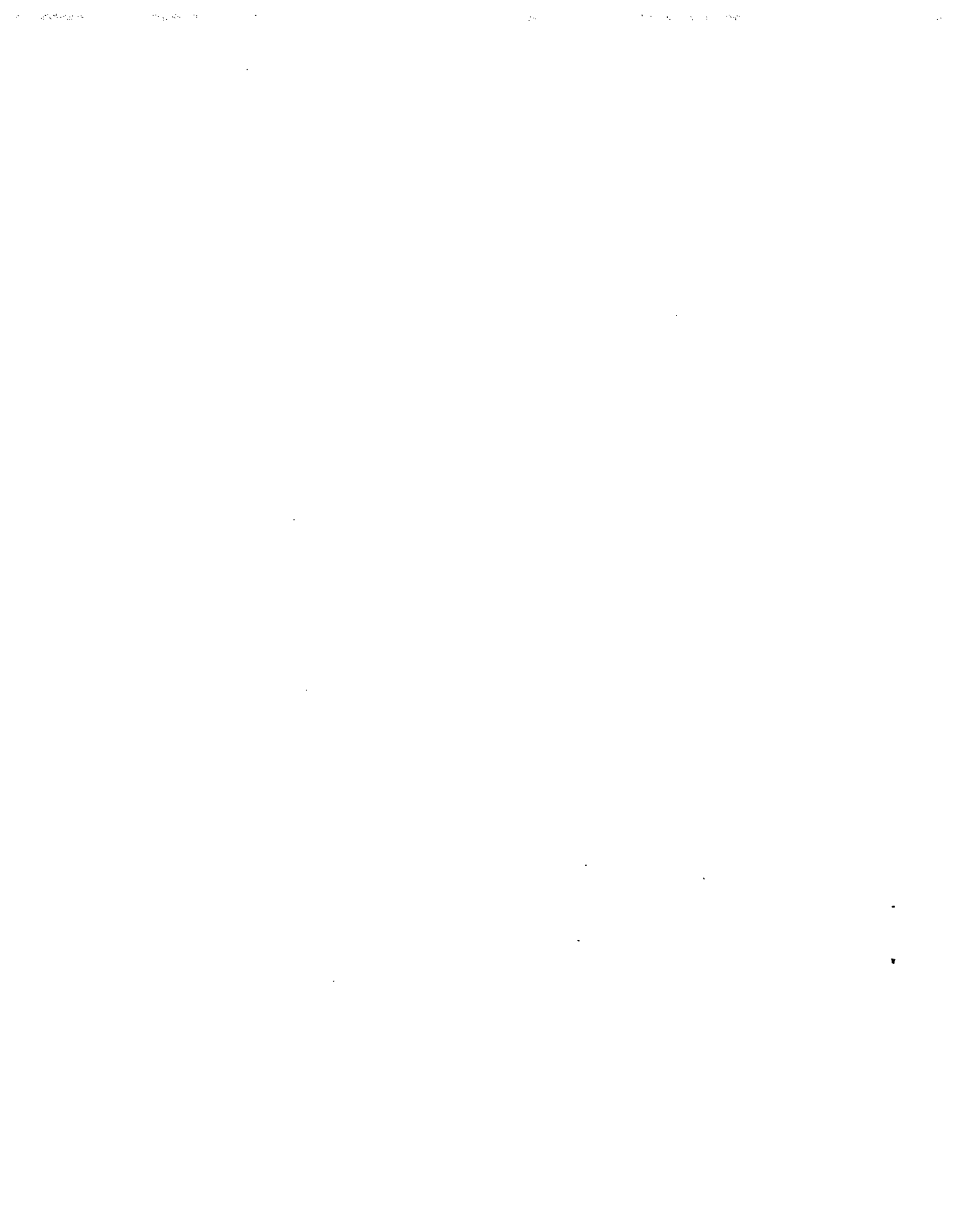

SECTION II – INSTALLATION

2-1 UNPACKING AND INSPECTION

2-2 This instrument has been thoroughly inspected and tested prior to packing and is ready for operation. After careful unpacking, inspect for shipping damage before attempting to operate. Perform the preliminary operational check as outlined in paragraph 2-8 below. If any indication of damage is found, file an immediate claim with the responsible transport service.

2-3 TERMINATIONS

- a) FRONT PANEL: Refer to FIG. 2-2 and Table 2-2.
- b) REAR: Refer to FIG. 2-3 and Table 2-3.
- c) INTERNAL CONTROLS: Refer to FIG. 2-1 and Table 2-1.

REFERENCE DESIGNATION	CONTROL	PURPOSE
R17	I_o MAX	Maximum Output Current
R24	E_o LAG	Voltage Channel Stability Control
R32	E_o ZERO	Voltage Channel Zero Control
R39	I_o ZERO	Current Channel Zero Control
R62	PREAMP "B" ZERO	Offset Zero Control for PREAMP "B"
R63	PREAMP "A" ZERO	Offset Zero Control for PREAMP "A"

TABLE 2-1 INTERNAL CONTROLS AND THEIR FUNCTIONS.

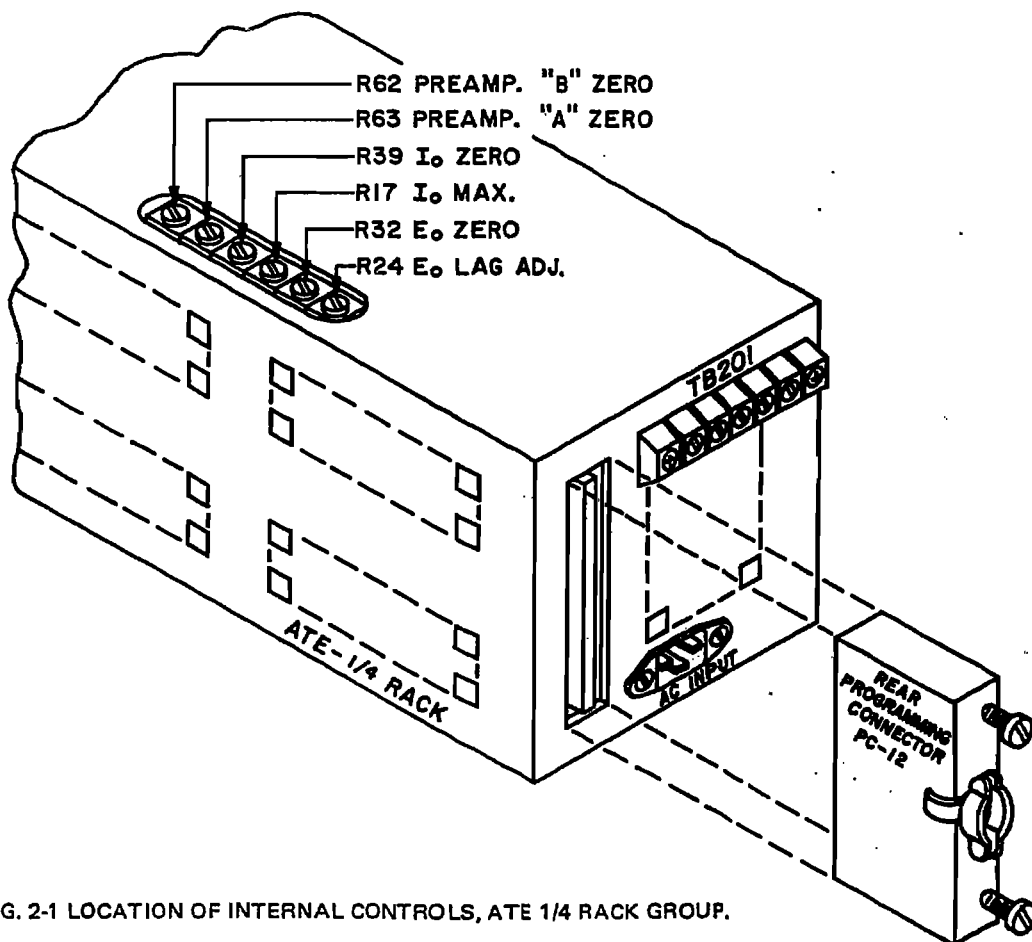

FIG. 2-1 LOCATION OF INTERNAL CONTROLS, ATE 1/4 RACK GROUP.

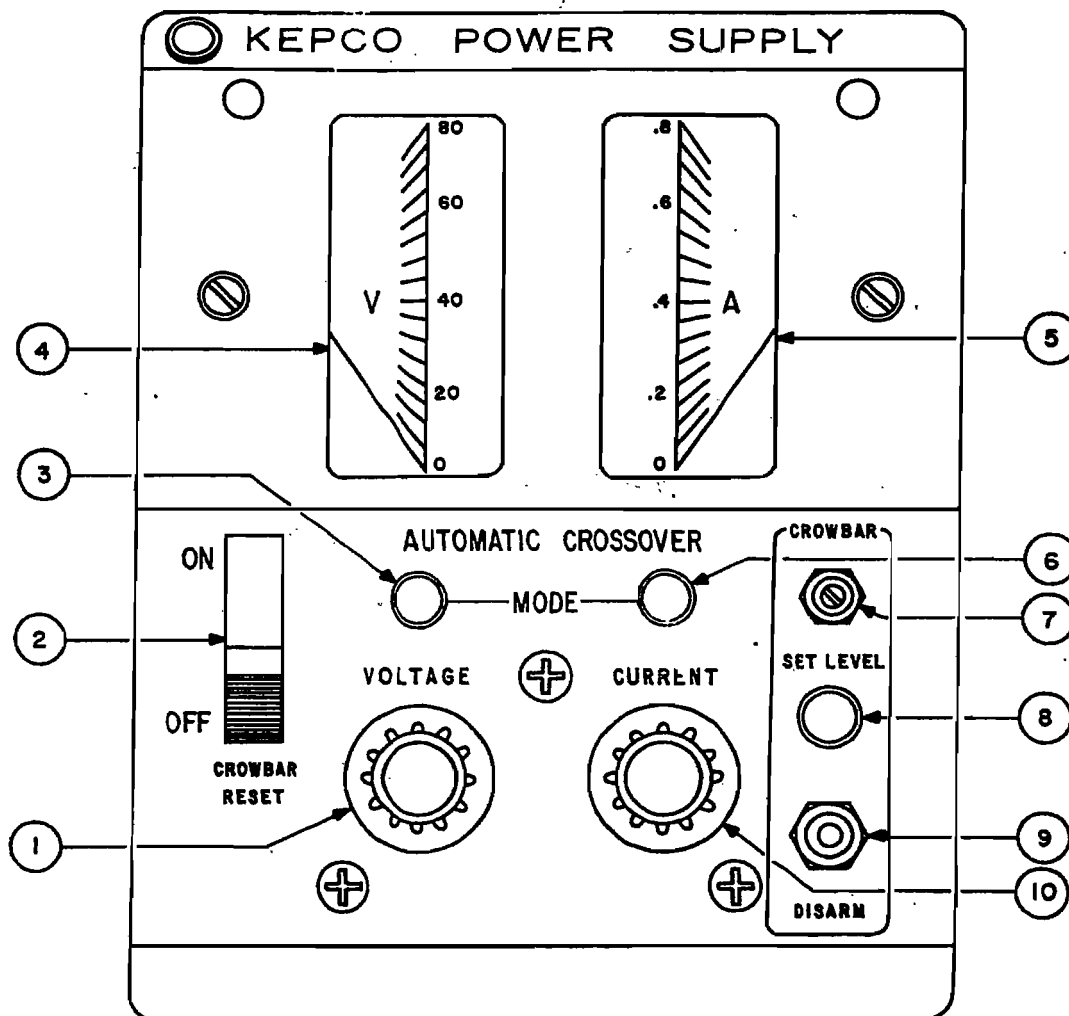

FIG. 2-2 CONTROLS AND TERMINATIONS, ATE 1/4 RACK GROUP, FRONT.

NO.	CONTROL OR TERMINATION	FUNCTION
1.	VOLTAGE CONTROL	ADJUSTS OUTPUT VOLTAGE FROM ZERO TO E_o max.
2.	A-C POWER SWITCH/ CIRCUIT BREAKER	SERVES AS A-C POWER SWITCH AND TURNS A-C POWER LINE "OFF" ON OVERLOAD
3.	"V" MODE INDICATOR	ENERGIZES IN VOLTAGE MODE
4.	VOLTMETER	MONITORS OUTPUT VOLTAGE 0- E_o max.
5.	AMMETER	MONITORS OUTPUT CURRENT 0- I_o max.
6.	"I" MODE INDICATOR	ENERGIZES IN CURRENT MODE
7.	"LEVEL" CONTROL	ADJUSTS TRIGGER LEVEL OF CROWBAR CIRCUIT
8.	CROWBAR INDICATOR	LIGHTS WHEN CROWBAR IS TRIGGERED "ON"
9.	"DISARM" PUSH-BUTTON	PUSH TO SET CROWBAR TRIGGER LEVEL
10.	CURRENT CONTROL	ADJUSTS CURRENT FROM 0-100% I_o max.

TABLE 2-2 CONTROLS AND TERMINATIONS, ATE 1/4 RACK GROUP, FRONT.

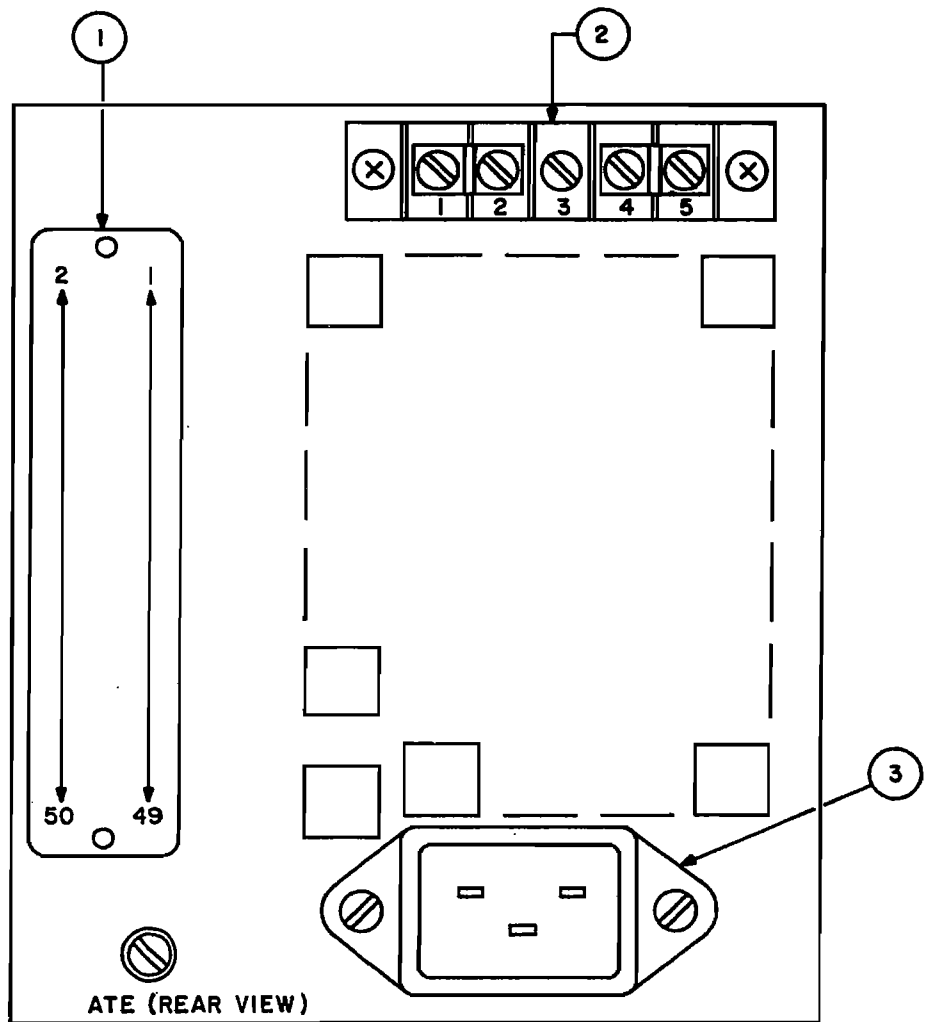

FIG. 2-3 TERMINATIONS, ATE 1/4 RACK GROUP, REAR.

NO.	TERMINATION	FUNCTION
1.	REAR MATING CONNECTOR (PC-12)	FOR EXTERNAL PROGRAMMING SOURCE INPUT AND ALL OTHER PROGRAMMING FUNCTIONS.
2.	OUTPUT TERMINALS, TB201	1) (-) SENSING 2) (-) D-C OUTPUT 3) GROUND (CHASSIS CONNECTION) 4) (+) D-C OUTPUT 5) (+) SENSING
3.	A-C POWER INPUT	ACCEPTS 3-WIRE A-C INPUT CORD (SUPPLIED)

TABLE 2-3 REAR TERMINATIONS, ATE 1/4 RACK GROUP, WITH PROGRAMMABLE VP, REAR.

2-4 A-C INPUT REQUIREMENTS

- 2-5 This power supply is normally supplied for operation on a single phase, nominal 115V a-c line. For conversion to other a-c source voltages, refer to FIG. 2-4. Select your nominal source voltage and change the links on the barrier strip of T201 according to the table provided in FIG. 2-4. The circuit breaker (CB101) remains equally effective at all input voltages.

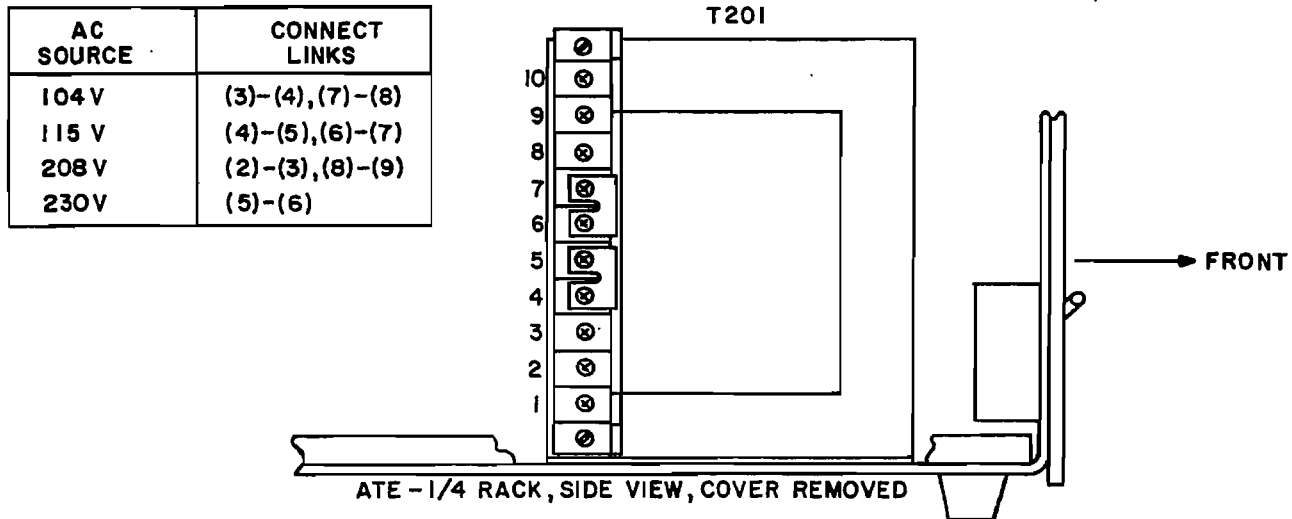

FIG. 2-4 A-C INPUT SOURCE VOLTAGE SELECTION, ATE 1/4 RACK GROUP.

2-6 COOLING

- 2-7 The power transistors and rectifiers in the ATE power supplies are maintained within their operating temperature range by means of special heat sink assemblies, cooled by internal fans. SIDE PANEL OPENINGS AND THE TOP OF THE CASE MUST BE KEPT CLEAR FROM OBSTRUCTIONS TO INSURE PROPER AIR CIRCULATION. Periodic cleaning of the interior of the power supply is recommended. If the power supply is rack mounted, or installed into confined spaces, care must be taken that the ambient temperature (the temperature immediately surrounding the power supply) does not rise above the limit specified (refer to Section I).

2-8 PRELIMINARY CHECK-OUT

- 2-9 A simple operating check after unpacking and before permanent installation is advisable to ascertain whether the power supply has suffered damage resulting from shipment. Refer to FIG. 2-2 and to FIG. 2-3 for the location of the operating controls and output terminals.

- Connect power supply to 115V a-c source or refer to par. 2-4 for other input voltages, if required.
- Turn CURRENT CONTROL fully clockwise. Turn VOLTAGE CONTROL fully counterclockwise.
- Turn A-C POWER SWITCH/CIRCUIT BREAKER "on". The VOLTAGE VIX indicator should be energized. Slowly turn VOLTAGE CONTROL clockwise and observe the gradual increase of the output voltage. The VOLTMETER should now read full scale.
- Check the overvoltage "crowbar" circuit as follows:
 - Turn the VOLTAGE CONTROL to about one-half of its range.
 - Depress the DISARM push button and turn the (recessed) LEVEL control *slowly* counterclockwise until the CROWBAR INDICATOR lamp lights up.
 - Turn VOLTAGE CONTROL slightly counterclockwise and release DISARM button.
 - To reset the adjusted crowbar point, press DISARM button again and advance VOLTAGE CONTROL clockwise. Note voltage at which the CROWBAR INDICATOR lights up. Readjust LEVEL control if necessary, by repeating step (2) and check again by repeating steps (3) and (4).
 - Turn A-C POWER SWITCH/CIRCUIT BREAKER "off".
- Place a short circuit across the ATE output terminals. Turn CURRENT CONTROL counterclockwise. Turn the ATE "on". THE CURRENT MODE indicator should now be energized. Slowly turn CURRENT CONTROL clockwise and observe the gradual increase in output current. The AMMETER should now read full scale.

2-10 INSTALLATION (Refer to FIG. 1-3 "Mechanical Outline Drawing")

- 2-11 The Power Supply may be rack-mounted or operated as a "bench-type" instrument. If the ATE is to rack-mounted, the (4) bottom feet must be removed.
- 2-12 For all installations into confined spaces, care must be taken that the temperature immediately surrounding the unit does not exceed the maximum specified ambient temperature (65°C).

2-13 GROUNDING

- a) A-C (SAFETY) GROUND. The power supply is equipped with a 3-wire safety line cord and polarized plug. The third (green) wire in the line cord is connected to the chassis and the case of the unit. If a 2-terminal receptacle in combination with an adapter is used, it is imperative that the chassis of the power supply be returned to a-c ground with a separate lead. A grounding terminal is provided (at the rear barrier strip) for this purpose.
- b) ISOLATION FROM GROUND. The d-c output is isolated from the a-c source and from any *direct* connection to chassis or ground. The maximum output voltage that can be supported between either output terminals and ground or chassis is 500V (d-c or peak), plus the maximum output voltage of the power supply. Either side of the output may be grounded.

A resistor/capacitor network (R59, C27), is connected from the negative output terminal to the metal chassis of the power supply (via QD-1). If the internal signal ground is *not* desired, the connection to the chassis can be opened by changing the wire lug position from QD-1 to QC-2 (See FIG. 2-5).

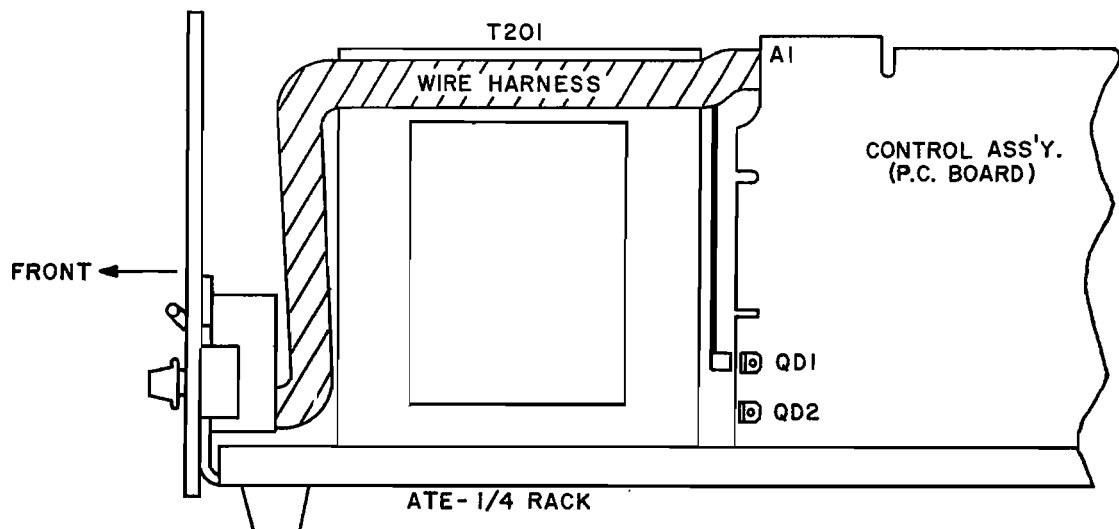

FIG. 2-5 LOCATION OF INTERNAL SIGNAL GROUND. SIGNAL GROUND NETWORK SHOWN CONNECTED VIA QD-1. TO REMOVE SIGNAL GROUND, PLACE WIRE LUG ONTO QD-2.

2-14 FAST MODE CONVERSION OF THE ATE POWER SUPPLY

- 2-15 Power supplies designed to operate in a voltage, as well as in a current stabilizing mode, often represent a compromise between the conflicting requirements of a good voltage and a good current source. A good voltage source must have **low** output impedance, good output voltage stability and good dynamic stability in the presence of loads with capacitive and/or inductive content. The power supply achieves these design goals by relying to a great extent upon a large output capacitor having a very low terminal impedance, large energy storing ability and great resistance to rapid voltage changes. Unfortunately, the requirements for a good current source are quite opposite to that of the voltage source described above. A current source should have **high** output impedance and its terminal voltage must be able to assume rapidly any value as may be needed to keep the output current at the predetermined level, while the load is changing.
- 2-16 To satisfy these conflicting requirements, the ATE power supply was designed for quick manual change-over from the "slow" mode to the "fast" mode of operation. In the "slow" mode, the ATE power supply approaches an ideal voltage source. Heavy output and feedback capacitors provide for low output noise, excellent voltage stability and good transient response. In the "fast" mode, the output and main feedback capacitors are completely removed, thereby providing the characteristics of a wide-band amplifier, ideal for applications requiring a current stabilizer or for high speed voltage or current programming.
- 2-17 MANUAL CHANGE-OVER, SLOW/FAST MODE. The ATE power supply is normally delivered for operation in the "slow" mode. By changing jumper connections at the rear of the power supply, the user can quickly convert from the "slow" mode to the "fast" mode or vice versa (See FIG. 2-6).

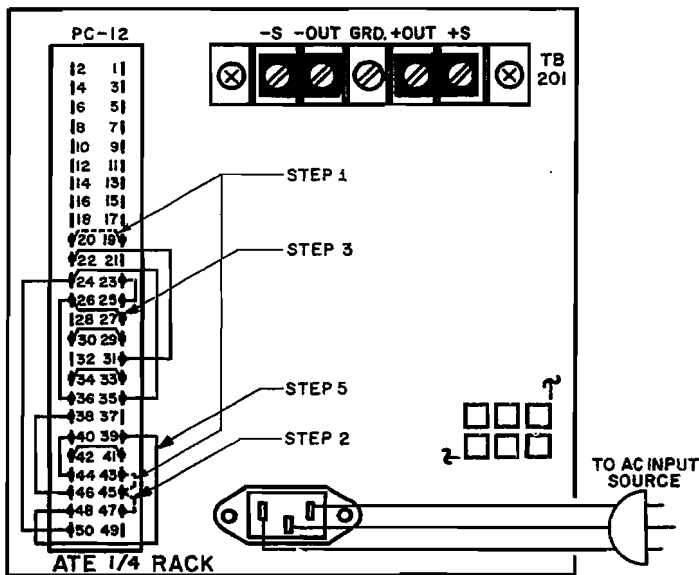

FIG. 2-6 REQUIRED STEPS FOR ATE
"FAST MODE" CONVERSION.

- STEP 1: Remove Links (19)-(20) and (43)-(45) on PC-12. This removes the output capacitor (C_o).
- STEP 2: Remove jumper (45)-(47) on PC-12. This removes the main feedback capacitor (C_f).
- STEP 3: Connect wire jumper on PC-12 from (26) to (27). This connects a lag network.
- STEP 4: Refer to Section II, FIG 2-5 and remove the internal grounding network.
- STEP 5: Connect wire jumper from (39) to (48) on PC-12. This introduces a required delay in the crowbar circuit.

NOTE: For fast mode operation into a load interrupted by contactors or relays ("Arcing Load"), a small, high-frequency-type capacitor may be required across the contacts of the interrupting device, or the power supply output terminals, or directly across the load terminals. A ceramic disc capacitor (0.01 μ F) has been found to be adequate to prevent spurious triggering of the overvoltage circuit.

- 2-18 PRECAUTIONS. The output capacitor, and to a lesser extent, the feedback capacitor of a power supply, control the programming speed and the current mode recovery time. The removal of these capacitors in the fast mode results in greatly improved power supply performance in these areas. The power supply's dynamic stability, however, is reduced, making the output sensitive to the load phase angle. For this reason, the load presented to the power supply in the fast mode must not contain excessive capacitance (limit: 1000pF). Also, with the output and main feedback capacitors removed, there will be an increase in the output noise, mainly high frequency noise and pick-up, so that external shielding of programming leads and good grounding practices assume added importance in the fast mode operation. See also note in FIG. 2-6.
- 2-19 LAG NETWORK ADJUSTMENT. The ATE power supply operating in the "fast" mode, is dynamically stabilized by means of an internal lag network (E_o LAG, R24, see FIG. 2-1 for location). This control should be adjusted, for each application, by monitoring the load with an oscilloscope and turning the LAG control for best output response and maximum dynamic stability under all operating conditions.
- 2-20 CROWBAR OPERATION, FAST MODE. The crowbar circuit in the ATE power supply is not completely removed in the "fast" operating mode, but continues to offer protection against d-c voltage surges which may harm the load.

SECTION III – OPERATION

3-1 GENERAL

- 3-2 Interconnections between an a-c power source and a stabilized power supply, and between the power supply and its load are as critical as the interface between other types of electronic equipment. If optimum performance is expected, certain rules for the interconnection of source, power supply and load must be observed by the user. These rules are described in detail in the following paragraphs.

3-3 SAFETY GROUNDING

- 3-4 National and international safety rules dictate the grounding of the metal cover and case of any instrument connected to the a-c power source.

WARNING

KEEP INSTRUMENT GROUNDED WHILE IT IS CONNECTED TO THE A-C POWER SOURCE.

- 3-5 Kepco power supplies with flexible a-c power cord are equipped with a 3-prong safety plug, which must be connected to a *grounded* a-c power outlet.

3-6 D-C (OUTPUT) GROUNDING

- 3-7 Connections between the power supply and the load (load and sensing connections), as well as connections to the power supply amplifiers (programming connections) may, despite all precautions such as shielding, twisting of wire-pairs, etc., "pick-up" radiated noise of a wide frequency spectrum. To minimize these undesired effects, one side of the power supply output/load circuit should be grounded.
- 3-8 Successful d-c grounding depends on careful analysis of the individual situation and only general guide lines can be provided here. One of the major points, however, is to avoid GROUND LOOPS. Ground loops are created when two (or more) points are grounded along the output circuit. Due to the wire impedance between the separated grounded points, a noise voltage is developed which subsequently is superimposed on the load. The only way to avoid ground loops is to investigate the output circuit (including the connected load) carefully by means of an ohmmeter for any resistance to ground. A single d-c ground point can be selected only if the output circuit is completely isolated, a single point is selected along the power supply output/load circuit and this point is returned to ground with a single wire. The exact location of this "best" d-c ground-point is entirely dependent on the application at hand. For single, isolated loads, the d-c ground-point may be located directly at one of the output terminals of the power supply which may be connected to ground. If error sensing is employed, d-c ground can be established at the remote load. In case of an internally grounded load, the d-c ground is automatically established directly at the load.
- 3-9 ATE Power Supplies have *one* side of the output returned to the case over a resistor/capacitor combination (refer to Section II, Par. 2-13). In those cases, therefore, where the *load* is internally grounded, or where the signal ground must be established elsewhere, the resistor/capacitor combination must be removed from the power supply case in order to avoid ground loop problems. If there is a choice in selecting either the positive or the negative output of the power supply for the d-c ground point, both sides should be tried, and preference given to the ground point producing the least noise. Output ripple specifications (as measured at the output) are, however, equally valid for either output side grounded. Care should be taken in measuring the ripple and noise at the power supply output or at the load. Measuring devices which are a-c line operated often introduce ripple and noise into the circuit.
- 3-10 In the case where the load must be kept completely off ground (d-c isolated) or it must be operated above ground potential, grounding can be accomplished by means of a suitable capacitor connected from either side of the power supply output to the signal ground. The size of the capacitor should be carefully selected. A value between 0.1 and 1 microfarad has been found to be successful in many cases.

3-11 Even simple remote control tasks, such as error sensing or resistance programming, require *careful shielding* with 2-wire shielding cable, with the shield (single-ended) returned to the single d-c ground point. In cases where external programming sources are used, additional precautions are required. If all other grounding problems have been solved and a single ground point has been assigned to the system, the programming source must be evaluated for system compatibility. Some of the older signal generators, for example, cannot be successfully used for programming, since their cases are connected permanently to one of the output leads. Aside from these initial problems, the power supply/load system must have the correct "polarity" for voltage programming; e.g., the programming source "common" must be connected to the previously grounded output side. If this is not possible, because of polarity considerations, three choices are open: either the programming source must be "floated;" i.e., it must operate above ground by an amount given by the output voltage of the power supply, or the selected d-c ground point must be changed to the polarity coinciding with that of the programming source, or the polarity of the programming source must be reversed by using the uncommitted preamplifiers of the ATE, as described in this section.

3-12 POWER SUPPLY/LOAD INTERFACE

3-13 The general function of a voltage or current stabilized power supply is to deliver the rated output quantities to the connected load. The load may have any conceivable characteristic: It may be fixed or variable; it may have predominantly resistive, capacitive, or inductive parameters; it may be located very close to the power supply or it may be a considerable distance away. The power supply designer cannot anticipate every conceivable application, location or nature of the load. He must design his product for the widest possible application range and specify the performance at the output terminals of the power supply. The aim of the following paragraphs is to aid the user in the final use of the product: The interface of the power supply and the load.

3-14 The perfect interface between a power source and its load would mean that the specified performance at the output terminals would be transferred without impairment to any load, regardless of its characteristics, distance from the power supply or environment. To approach this ideal, the power supply must satisfy certain requirements, interconnecting rules must be closely followed and Ohm's Law, as well as basic a-c theory must be considered in selecting the interface wiring.

3-15 **LOAD WIRE SELECTION.** The stabilized d-c power supply is definitely not an ideal voltage or current source with zero output impedance (VOLTAGE MODE) or infinite output impedance (CURRENT MODE) at all frequencies: All *voltage* sources have some amount of impedance which *increases* with frequency and all *current* sources have an output impedance which *decreases* with frequency (refer to FIG. 3-1).

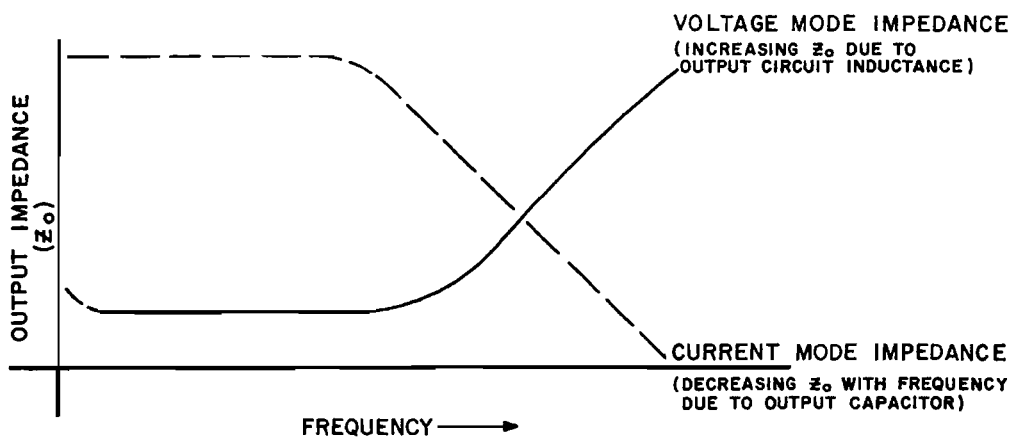

FIG. 3-1 TYPICAL OUTPUT IMPEDANCE VS. FREQUENCY PLOT FOR STABILIZED D-C SOURCES.

NOTE: Load connections for application requiring solely stabilized *output current* are not as critical as those requiring stabilized *output voltage*:

- a) D-C wire drops do not influence the current stabilizing action, but must be subtracted from the available compliance voltage.
- b) Wire inductance is "swamped-out" by the action of the output capacity.

Emphasis in the following paragraphs is therefore placed on the power supply as a *voltage source*, rather than a current source.

A more realistic model for a voltage stabilized power supply must, for example, include a series resistance, representing the small d-c and low frequency source impedance, in series with an inductance, representing the source impedance at higher frequencies. Load wire selection should therefore proceed with those facts in mind. The load-wire size should not only be selected for minimum voltage drop (Error Sensing, as discussed below, will take care of that), but also the series inductance of the load wire must be kept as small as possible compared to the source inductance of the power supply (Error Sensing *cannot* compensate for this). These dynamic considerations are especially important if:

- 1) The load is constantly changing in value.
- 2) The load is switched "on" and "off."
- 3) The output of the power supply is step programmed.
- 4) The load has a primarily reactive characteristic.
- 5) All other cases where the dynamic output response of the power supply is considered important.

3-16 LOAD CONNECTION, GENERAL

3-17 Kepco has provided a group of terminals on the programming connector PC-12 and on the barrier strip (TB210) at the rear of the power supply, which permit maximum flexibility in power supply/load interface techniques. Although all applications tend to exhibit their own problems, the basic interconnections described may be used as a general guide in the interconnection between power supply and load.

3-18 (Refer to FIG. 3-2). The Kepco power supply is shipped from the factory with several jumper links, connected to the programming connector (PC-12) and to the barrier strip (TB201). These links may be removed and replaced at will, depending on the operating mode and application of the power supply. Positioned as shown in FIG. 3-2, the links are connected for front panel (local) control of the output voltage, output current and VP crowbar level with the power supply operating in the "slow" mode. *Links remaining on the mating jack must be soldered, links on the barrier strip must be tightened.* LOOSE WIRES OR LINKS AT THE BARRIER STRIP OR THE MATING JACK WILL CAUSE MALFUNCTION OF THE POWER SUPPLY.

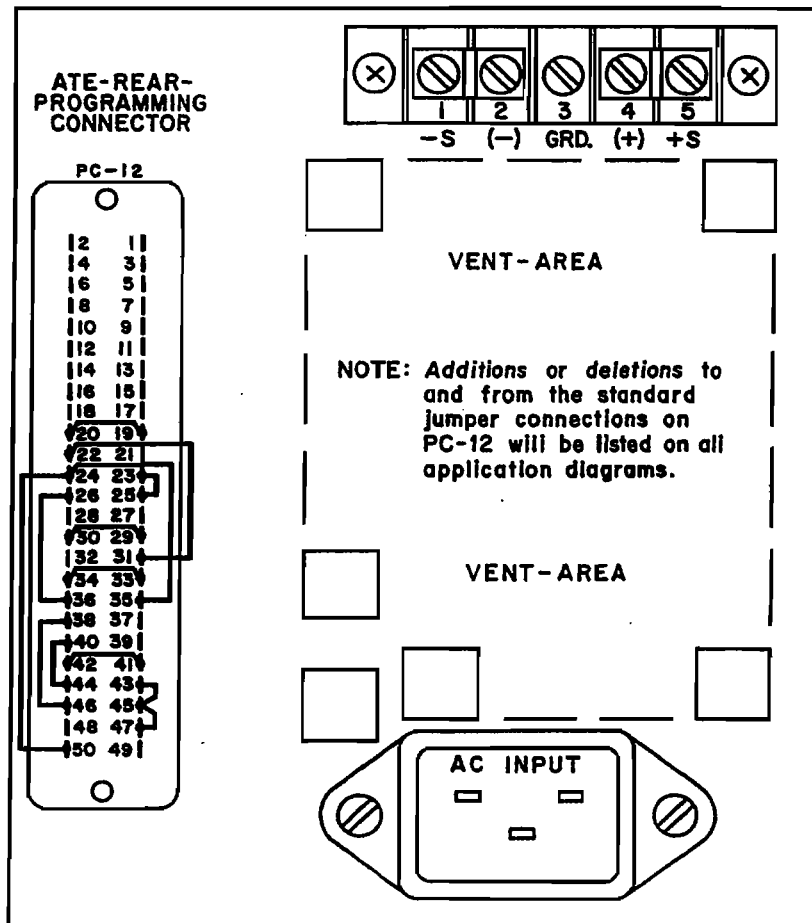
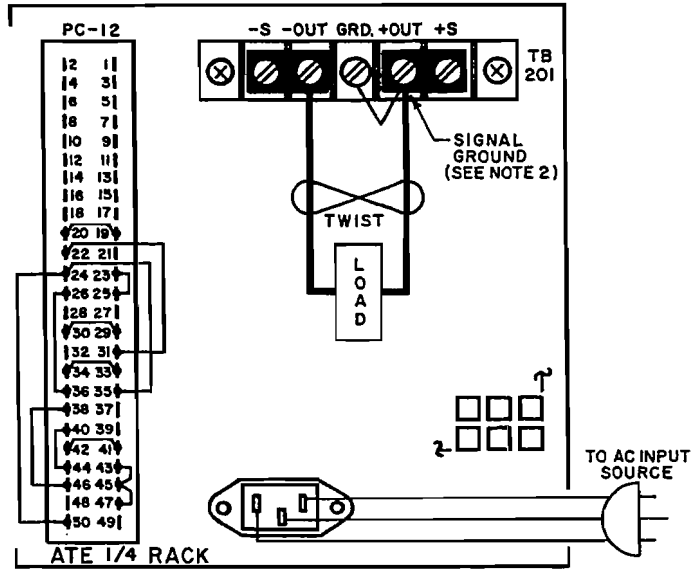

FIG. 3-2 STANDARD JUMPER LINK CONNECTIONS FOR LOCAL (FRONT PANEL) CONTROL OF THE OUTPUT VOLTAGE, OUTPUT CURRENT AND VP CROWBAR LEVEL (SLOW MODE).

3-19 LOAD CONNECTION, METHOD I (LOCAL ERROR SENSING)

3-20 (Refer to FIG. 3-3). The most basic power supply interconnection, to primarily resistive, relatively constant loads, located close to the power supply, or for loads requiring stabilized current exclusively, consists of 2-wire connection from the rear output terminals. Load wire is selected as described previously (refer to par. 3-15). The load leads should be tightly twisted to reduce "pick-up" from stray magnetic fields. After the grounding rules have been applied (refer to par. 3-3 to 3-11), the power supply can be connected to the a-c source and operation may commence.



NOTES:

- 1) For Operator Safety all connections to and from the power supply should be made *before* a-c power is applied.
- 2) *Alternate* signal ground points may be chosen: refer to PAR. 3-6.
- 3) *Twist* all wire pairs. Use shielding as indicated.

FIG. 3-3 LOAD CONNECTION METHOD I, LOCAL ERROR SENSING.

3-21 LOAD CONNECTION, METHOD II (REMOTE ERROR SENSING)

3-22 To avoid excessive output effects at remote loads, error sensing must be used. A twisted, shielded pair of wire from the sensing terminals directly to the load will compensate for load wire voltage drops up to 0.5 volt per wire (refer to FIG. 3-4). Observe polarities: The *negative sensing wire* must go to the *negative load wire*, and the *positive sensing wire* goes to the *positive load wire*.

NOTE: For long wire runs, twisting each sensing wire with its associated load wire may give improved results in some cases.

FIG. 3-4 LOAD CONNECTION, METHOD II USING REMOTE ERROR SENSING.

ATTENTION

When using remote error sensing with large capacitive loads and long load and sensing wires, low frequency oscillations may be observed at the load. To eliminate the problem the **FEEDBACK CAPACITOR** should be disconnected from the (-) OUTPUT SENSING terminal and reconnected to the (-) OUTPUT terminal. Remove jumper (45) - (47) on the REAR PROGRAMMING CONNECTOR. Connect a short wire from pin 47 to the (-) OUTPUT terminal on the rear barrier-strip (TB201).

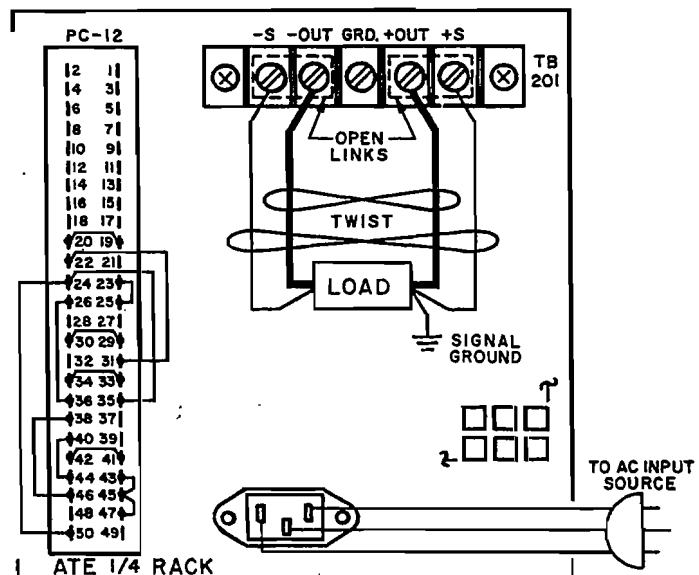

3-23 This method of load interconnection is suitable for loads which do not require rapid changes in voltage or current or for programming with gradually changing waveforms (sine wave, triangular wave shapes, etc.). See par. 3-24 for load connections suitable for rapid (step) changes in the load or in programming.

3-24 LOAD CONNECTION, METHOD III

3-25 This method is suitable if step changes in the load are expected if, for example, the load is rapidly changing in value, or if the power supply is programmed with step functions (square wave, pulse, etc.) and maximum dynamic performance is expected directly at the load terminals. In these cases, the output capacitor is disconnected at the power supply and brought with a heavy, twisted-wire pair directly to the remote load (refer to FIG. 3-5).

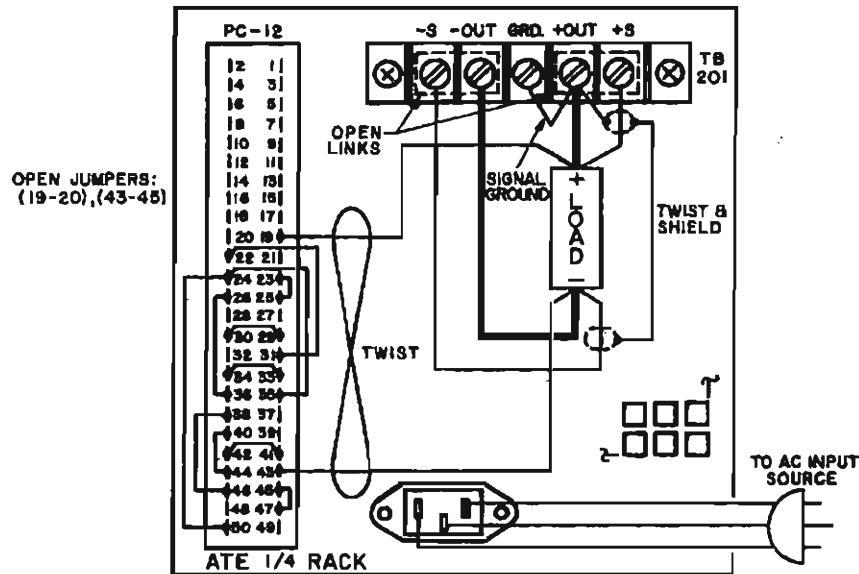

FIG. 3-5 LOAD CONNECTION, METHOD III.

3-26 Since the output capacitor is now removed from the output terminals of the power supply and directly connected to the load, it may be possible in some cases that it can no longer perform its bypass function as far as the *power supply* is concerned. If oscillations are observed at the output or at the load, C_o should be left connected in the power supply (by connecting (1)-(3) and (5)-(7) on TB201). The load should be decoupled with another high quality capacitor of a value equal to or greater than C_o . Alternately, good results can sometimes be achieved by disconnecting the internal C_o and operating with an external bypass capacitor across the load exclusively. For pulsed loads which drop to zero current during the "off" period, any external output capacitor should be paralleled with a "bleeder" resistor. The value of this resistor is determined by the value of the external capacitor, the desired response and the amount of output current which can be sacrificed. As a minimum, the RC time constant of the external output capacitor (C_o ext.) and the bleeder resistor (R_o ext.) should be comparable with the internal output capacitor (C_o) and the bleeder resistor (R_o), so that:

$$R_o \text{ ext. } C_o \text{ ext.} \leq R_o C_o$$

NOTE: C_o (C26), R_o (R203) = 1,000 μ F, 500 Ω for ATE 6-5M, DM; 470 μ F, 750 Ω for ATE 15-3M, DM;
 280 μ F, 1,000 Ω for ATE 25-2M, DM; 220 μ F, 2,000 Ω for ATE 36-1.5M, DM;
 160 μ F, 4,000 Ω for ATE 55-1M, DM; 120 μ F, 6,000 Ω for ATE 75-0.7M, DM;
 60 μ F, 10,000 Ω for ATE 100-0.5M, DM; 55 μ F, 20,000 Ω for ATE 150-0.3M, DM.
 2,000 μ F, 2,500 Ω for ATE 6-10M, DM; 1,000 μ F, 5,000 Ω for ATE 15-6M, DM;
 530 μ F, 7,500 Ω for ATE 25-4M, DM; 470 μ F, 1,000 Ω for ATE 36-3M, DM;
 220 μ F, 1,500 Ω for ATE 55-2M, DM; 120 μ F, 3,000 Ω for ATE 75-1.5M, DM;
 84 μ F, 5,000 Ω for ATE 100-1M, DM; 55 μ F, 10,000 Ω for ATE 150-0.7M, DM.

NOTE: There is, unfortunately, no "best" method for interconnecting the load and the power supply. Individual applications, location and nature of the load require careful analysis in each case. Grounding a single point in the output circuit is of great importance. It is hoped that the preceding paragraphs will be of some assistance in most cases. For help in special applications or difficult problems, consult directly with Kepco's Application Engineering Department.

3-27 VOLTAGE MODE OPERATION (FRONT PANEL CONTROL)

3-28 Once the load is connected to the output terminals of the ATE Power Supply and safety, as well as grounding rules have been applied as described (refer to par's. 3-1 through 3-26), power supply operation can proceed:

- 1) Turn VOLTAGE CONTROL completely counterclockwise. Turn A-C POWER SWITCH/CIRCUIT BREAKER "on" (The voltage mode VIX indicator should be "on"). Observe front panel VOLTMETER and adjust VOLTAGE CONTROL to the desired output voltage level. Turn a-c power "off".

- 2) Turn the current control completely counterclockwise.
- 3) Apply a short circuit across the output terminals of the ATE Power Supply. Turn A-C POWER SWITCH/CIRCUIT BREAKER "on" (the current mode VIX indicator should be "on").
- 4) Observe front panel CURRENT METER and adjust CURRENT CONTROL to the required load current value, plus 2%. In voltage mode operation, this setting will determine the voltage/current "crossover" point. Turn A-C POWER SWITCH/CIRCUIT BREAKER "off".
- 5) Remove the short circuit from the output terminals. The power supply is now ready for operation.

3-29 CURRENT MODE OPERATION (FRONT PANEL CONTROL)

Note: Refer to Section I, par. 2-14 for fast mode conversion of the ATE.

3-20 Apply all safety and output grounding rules as described in previous paragraphs (refer to par's. 3-1 through 3-16). Proceed as follows:

- 1) **BEFORE** connecting the load to the power supply output terminals: Turn A-C POWER SWITCH/CIRCUIT BREAKER "on" (the voltage mode VIX indicator should be "on"). Observe the front panel VOLTMETER and adjust the VOLTAGE control to the required compliance (output voltage) level. Turn A-C POWER SWITCH/CIRCUIT BREAKER "off" and connect a short circuit to the output terminals of the ATE.
- 2) Turn A-C POWER SWITCH/CIRCUIT BREAKER "on". Observe the front panel CURRENT METER and adjust CURRENT control to the desired value. The current mode VIX indicator should go "on" to indicate that the power supply is truly in the current mode of operation. Turn A-C POWER SWITCH/CIRCUIT BREAKER "OFF".
- 3) Remove the short circuit, connect the load and turn A-C POWER SWITCH/CIRCUIT BREAKER "on". If the ATE does not enter the current mode (as indicated by the front panel "VIX" indicator), the load resistance (R_L) is too high. *Either* R_L must be *decreased*, *or* the VOLTAGE CONTROL setting must be *increased*, *or* the CURRENT CONTROL setting must be *decreased*. The ATE is now ready for operation.

3-31 OVERVOLTAGE CROWBAR, SETUP AND CHECK

3-32 The overvoltage crowbar circuit protects the load from momentary or long-term overvoltages. The crowbar SCR conducts across the power supply output, and the A-C POWER SWITCH/CIRCUIT BREAKER is tripped if such overvoltages occur. The setting of the front panel LEVEL control determines the "threshold" between the actual operating voltage of the power supply and the level at which the crowbar circuit will be activated. The LEVEL control can be set from 3 volts to 110% of the rated output voltage. The LEVEL control may be adjusted very close to the operating voltage (minimum threshold = 2% of rated output voltage or 0.5 volt, whichever is greater). The operation of the crowbar circuit can be checked *without* actually triggering the crowbar. All operating controls are accessible at the front panel (refer to FIG. 2-2, SECTION II).

3-33 SETUP AND CHECK PROCEDURE

- 1) Without connecting the load to the power supply turn LEVEL control *fully clockwise*.
- 2) Turn A-C POWER SWITCH/CIRCUIT BREAKER "on", observe the front panel VOLTMETER, and set VOLTAGE CONTROL to the desired value *at which the crowbar must trigger* (NOT to the actual operating voltage).
- 3) Depress the DISABLE button (and keep it depressed) while turning the LEVEL control *counterclockwise*, until the crowbar INDICATOR energizes (simulated crowbar action).
- 4) Turn VOLTAGE CONTROL slightly *counterclockwise* to *the actual operating voltage*. Release the DISABLE button.

NOTE: This last adjustment established the "threshold" i.e., the difference voltage between the output voltage and the voltage at which the power supply will "crowbar". For minimum "false triggering" use the largest threshold your load can tolerate.

- 5) To check the adjusted crowbar trigger level, depress DISARM push button and turn VOLTAGE CONTROL *clockwise*. Observe front panel VOLTMETER and note the voltage at which the crowbar INDICATOR lamp energizes. Correct LEVEL adjustment as described above if necessary. Reduce power supply output voltage to its operating value.

NOTE:1) Readjustment of the LEVEL control may be required after load and power supply have reached thermal equilibrium.

NOTE:2) If an *exact* crowbar point at a *remote load* must be established, *remote error sensing*, as described in par. 3-21 must be used.

3-34 INTRODUCTION TO REMOTE CONTROL OF THE ATE OUTPUT

- 3-35 GENERAL (REFER TO THE FOLD-OUT DRAWING AT THE END OF THIS SECTION. For local (front panel) control, the VOLTAGE CONTROL CHANNEL, the CURRENT CONTROL CHANNEL and the OVERVOLTAGE PROTECTOR of the ATE are locally adjusted by means of their respective front panel controls, with the jumper connections on the REAR PROGRAMMING CONNECTOR as shown. The internal control voltages for the VOLTAGE and CURRENT CONTROL CHANNELS are created by their individual control amplifiers, while the OVERVOLTAGE PROTECTOR "crowbar level" is adjusted by a potentiometer, connected across the (+)15 volt supply.
- 3-36 By disconnecting the internal control sources at the REAR PROGRAMMING CONNECTOR and substituting remote control circuitry, the ATE VOLTAGE and CURRENT CONTROL CHANNELS, as well as the OVERVOLTAGE PROTECTOR crowbar level, can be programmed externally. Control can be exercised individually or simultaneously on all three programming channels, although individual programming will be illustrated and discussed in the following paragraphs.

3-37 PROGRAMMING THE VOLTAGE CONTROL CHANNEL

- 3-38 GENERAL. The ATE output voltage which is controlled by a front panel VOLTAGE CONTROL in the Local control mode, can be remotely controlled by disconnecting the internal VOLTAGE CONTROL AMPL at the REAR PROGRAMMING CONNECTOR (PC-12) and substituting an external control signal at the input of the VOLTAGE COMPARISON AMPL with reference to the PROGRAMMING COMMON. For this "direct drive" method of voltage control, the control signal must be a positive going 0-10 volt d-c voltage source, able to supply at least 1 mA of control current. An application, demonstrating this control method is described in PAR. 3-41, and illustrated in FIG. 3-6.
- 3-39 Since all terminals of two independent preamplifiers (PREAMP "A", PREAMP "B") are available at the REAR PROGRAMMING CONNECTOR, output voltage control can be exercised in many other ways. Each preamplifier can be used as an uncommitted operational amplifier using the applicable transfer functions. The *static offsets* of each preamplifier can be zeroed with the built-in ZERO controls. The *offset variations* for each preamplifier, versus the various influence quantities, are specified in Section I of this manual (Refer to Table 1-2).
- 3-40 Making use of the ATE preamplifiers allows the user to accommodate a variety of programming sources. The basic principle to keep in mind is that a 0 to 10 volts, 1 mA signal, presented at the VOLTAGE COMPARISON AMPL input, will program the ATE output over its rated output voltage range. If the available programming input source does not have the required amplitude, or if the required control current cannot be supplied, the ATE preamplifiers can be used to adapt most input sources and provide the required parameters. The examples presented in the following paragraph should suffice to outline the wide variety of programming circuits which are possible with the ATE power supply.

3-41 OUTPUT VOLTAGE CONTROL WITH AN EXTERNAL 0-10 VOLT D-C CONTROL SIGNAL

- 3-42 An interesting example of the direct drive method of voltage programming is the control of the ATE output voltage by means of a Kepco Digital Programmer. The IEEE 488 bus compatible Kepco SN-488 system for example, responds to digital input data and can be addressed either by a computer, or manually. The output signal of the SN-488 is a voltage from zero to 10 volts or zero to 1 volt and constitutes the input program for the ATE. Since the SN-488 has two independent outputs (A,B), only one output is needed for voltage control, while the other may be used to control the ATE output current (See par. 3-60).

3-43 PROCEDURE (VOLTAGE CONTROL WITH AN EXTERNAL 0-10 VOLT, 1 mA D-C CONTROL SIGNAL)

- 1) Connect the EXT. CONTROL VOLTAGE, (SN-488 DIGITAL PROGRAMMER), the LOAD and the PRECISION VOLTMETER (M1) to the ATE as shown in FIG. 3-6.
- 2) With the SN-488 at zero, turn the ATE "on".
- 3) Vary the input voltage from the SN-488 from zero to 10 volts. The ATE output voltage, as read-out on M1, should vary from approximately zero volts to its maximum rated output voltage. Return the SN-488 output to zero volts.

3-44 CALIBRATION (Refer to Section II, FIG. 2-1 for the location of all internal controls).

- 1) Check the PRECISION VOLTMETER (M1) for "zero" reading and correct, if necessary, with the ATE E_0 ZERO control.
- 2) Set the MODEL SN-488 input to 10 volts. Observe M1 and calibrate the ATE output voltage to the exact maximum rated output voltage by means of the SN-488 calibration control.
- 3) Set the MODEL SN-488 output to "zero" again and check the previously calibrated zero point on M1. Correct with the ATE E_0 ZERO control if required.
- 4) Set the ATE front panel CURRENT CONTROL according to your load requirements, following the procedure given in PAR. 3-28 (2,3,4,5), or use one of the output current programming circuits for remote control of the output current as described in PAR.'s 3-60 or 3-64.

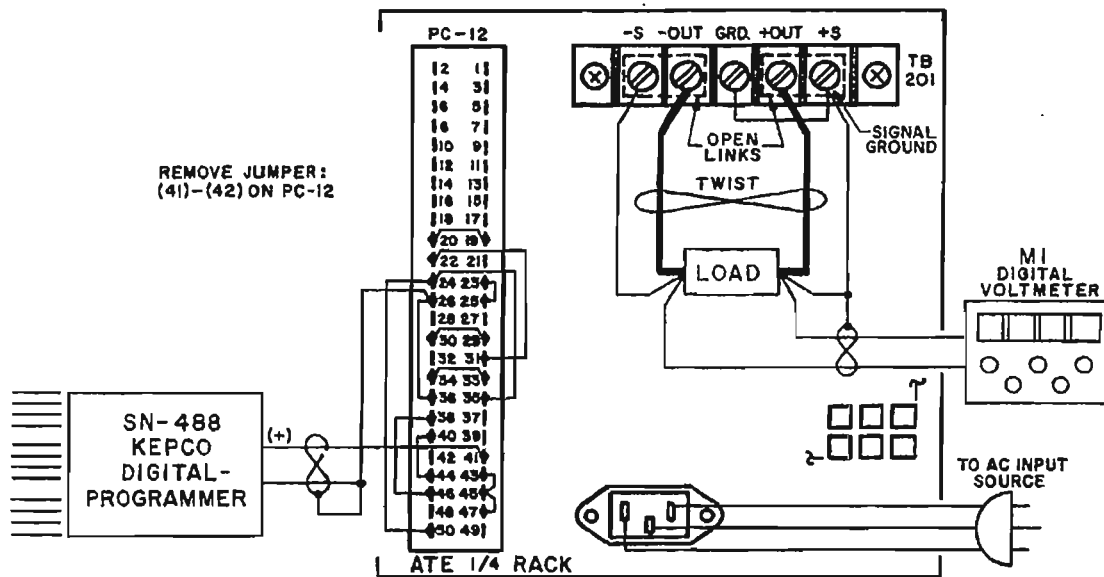

FIG. 3-6 OUTPUT VOLTAGE CONTROL WITH AN EXTERNAL (0-10V, 1 mA) D-C CONTROL SIGNAL.

3-45 VOLTAGE CONTROL WITH A TWO-TERMINAL RESISTANCE

3-46 As mentioned previously (refer to PAR.'s 3-39, 3-40) a wide variety of external programming sources can be used to control the ATE voltage channel. By means of one or both of the ATE's uncommitted preamplifiers, the external control potential can be amplified, inverted and/or summed with an internal d-c signal. Alternately, the preamplifier can be used to perform remote, two-terminal resistance programming of the ATE voltage channel. As seen in FIG. 3-7, the INT. REFERENCE SOURCE (6.2V @ 1 mA) is connected to PREAMP "A" and the external input/feedback components are calculated to produce the required 0 to 10 volts control signal from the preamplifier output.

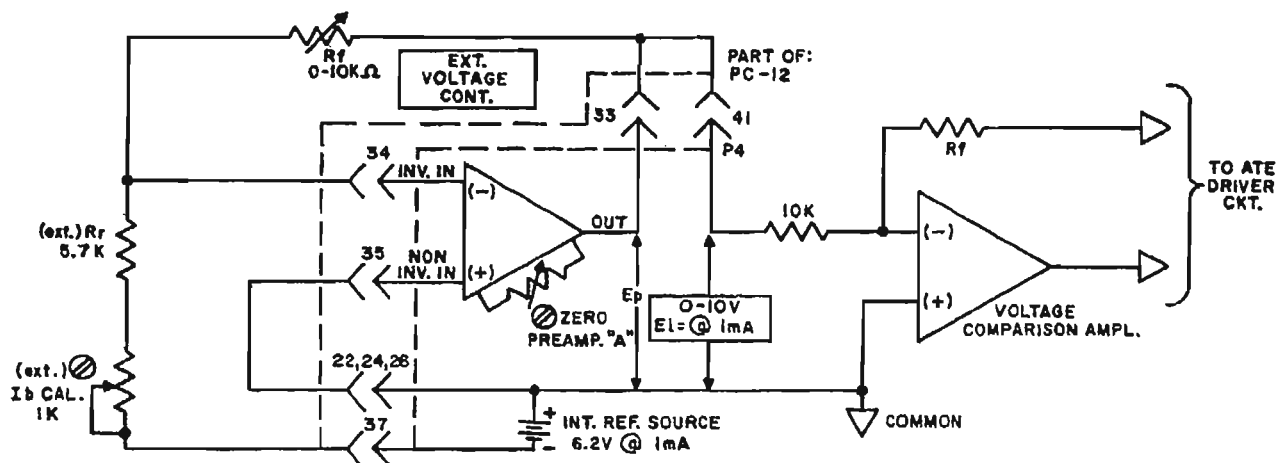

FIG. 3-7 TWO-TERMINAL RESISTANCE PROGRAMMING OF THE VOLTAGE CHANNEL, USING PREAMP "A" AND THE INTERNAL REFERENCE SOURCE.

3-47 (Refer to FIG. 3-7). The preamplifier functions here in the inverting configuration, producing its output voltage (E_p , which is made equal to the required control voltage " E_i ") according to the equation:

$$E_p = \frac{E_{ref}}{R_r} \times R_f \quad (\text{Eq. 1})$$

where:

- R_r = Ext. Reference resistor
- E_p = Preamplifier output voltage equal to the required control voltage (E_i)
- E_{ref} = Internal Reference Voltage 6.2V
- R_f = Ext. Feedback Resistor (Voltage Control)

Since the ratio E_{ref}/R_r may be expressed as a control current ($E_{ref}/R_r = I_b$), Eq. 1 can be simplified to read:

$$E_p = E_o \text{ (Preamplifier)} = I_b R_f \quad (\text{Eq. 2})$$

3-48 If I_b is selected to be 1 mA for example (Control Currents from approximately 0.1 to 1 mA can be selected), a 0 to 10K ohm reostat, decade or other variable resistance will produce the required 0–10 volt control potential and thereby control the ATE output voltage from zero to its maximum rated value. If a 0–10K ohm voltage control resistance is *not* available, the control current (I_b) can be changed to accommodate the available resistance value, making use of the preamplifier output equation (Eq. 2). If, for example, a 15K ohm precision potentiometer is available, the control current (I_b) must be: $10V/15K\Omega = 0.66$ mA. Since the built-in INT. REF. SOURCE is a (nominal) 6.2 volt, the external R_r must be: $6.2V/0.66 \text{ mA} \approx 9.4K\Omega$, which can be made up from a $8K\Omega$ fixed, and a $2K\Omega$ trim resistor (I_b CAL.).

3-49 PROCEDURE, VOLTAGE CONTROL WITH A TWO-TERMINAL RESISTANCE

- 1) Connect the external components, the LOAD and the PRECISION VOLTMETER (M1) to the ATE as shown in FIG. 3-8.
- 2) With the EXT. VOLTAGE CONTROL at zero ohms, turn the ATE "on".
- 3) Vary the EXT. VOLTAGE CONTROL from zero ohms to its maximum resistance. The ATE output voltage, as read out on M1, should vary from approximately zero volts to its rated maximum value. Return the EXT. VOLTAGE CONTROL to its zero ohm position.

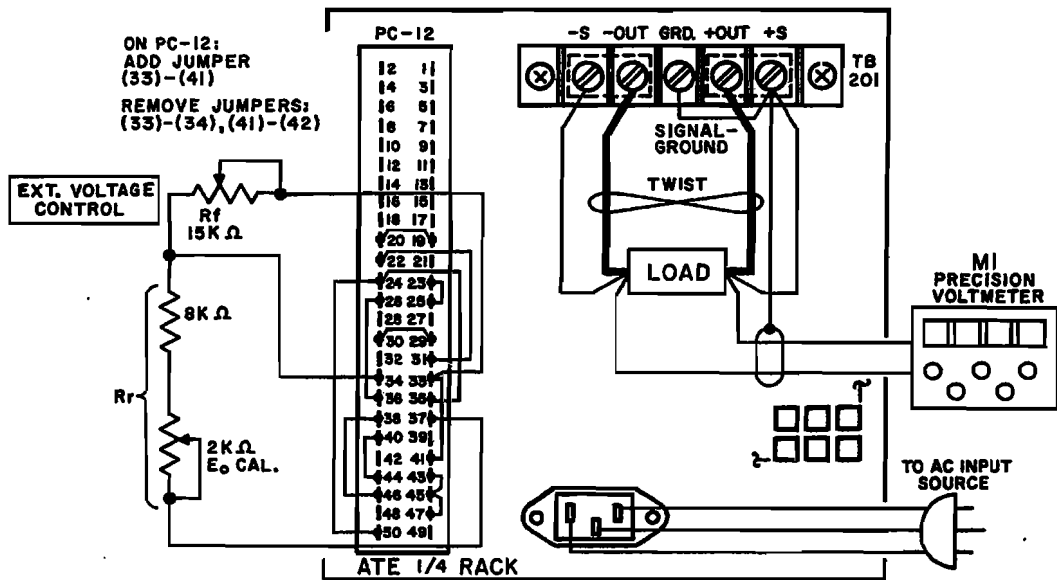

FIG. 3-8 CONNECTIONS FOR VOLTAGE CONTROL WITH A TWO-TERMINAL RESISTANCE.

3-50 CALIBRATION (Refer to Section II, FIG. 2-1 for the location of *all* internal controls).

- 1) Check the PRECISION VOLTMETER (M1) for "zero" reading and correct, if necessary, with the PREAMP "A" ZERO control.
- 2) Set EXT. VOLTAGE CONTROL to its maximum resistance. Observe M1 and calibrate the ATE output voltage to the exact maximum rated value by adjusting the EXT. I_b CAL. control.
- 3) Set EXT. VOLTAGE CONTROL to zero ohms again, re-check the previously calibrated zero point on M1 and correct with the PREAMP "A" ZERO control if required.
- 4) Set the ATE front panel CURRENT CONTROL according to the LOAD requirements, following the procedure given in PAR. 3-28 (2,3,4,5) or use one of the output current programming circuits for remote control of the output current as described in PAR.'s 3-60 or 3-64. Set the overvoltage protector as described in PAR. 3-31.
- 5) Operation can now proceed. Check the ATE power supply output, by means of an oscilloscope, for dynamic stability and output ripple amplitude. Refer to PAR. 3-6 if high ripple is present. If the power supply output is dynamically unstable (oscillations), review the paragraphs on power supply/load interface and grounding (PAR.'s. 3-6 through 3-26). Adjust the E_o LAG control if the ATE is configured for fast mode operation.

3-51 VOLTAGE CONTROL WITH A HIGH IMPEDANCE CONTROL SOURCE

3-52 External control sources which cannot supply at least $100\mu A$ of control current can be best accommodated by using one of the preamplifiers in the non-inverting configuration. The control source is connected to the ATE as shown in FIG. 3-9.

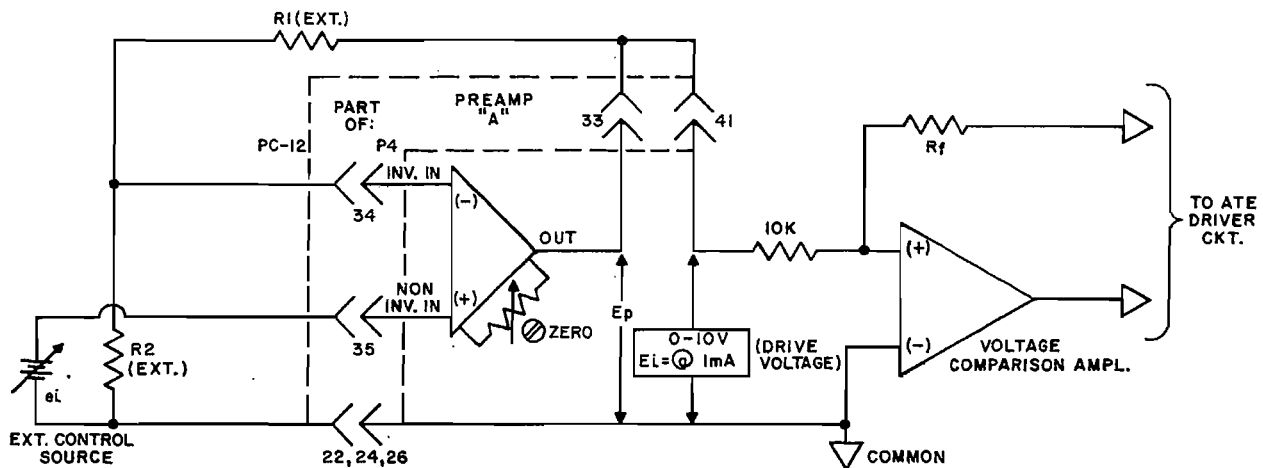

FIG. 3-9 USING PREAMP "A" TO GENERATE THE 0-10V @ 1 mA CONTROL POTENTIAL FROM A HIGH IMPEDANCE SOURCE.

3-53 (Refer to FIG. 3-9). The preamplifier output voltage (E_p) is made equal to the required drive voltage " E_i " by calculating the external resistors (R_1 , R_2) for the required gain, using the equation:

$$E_i = E_p = e_i \times \frac{R_1 + R_2}{R_2} \quad (\text{Eq. 3}), \quad \text{where:} \quad \begin{array}{l} E_p = \text{Preamplifier Output Voltage,} \\ \text{equal to the required drive} \\ \text{voltage } (E_i) \\ e_i = \text{Available control source.} \\ R_1, R_2 = \text{External feedback resistors.} \end{array}$$

3-54 If, for example, a 0 to 0.5 volt control source is available, the preamplifier gain, and therefore the ratio ($R_1 + R_2$) over R_2 must equal $10/0.5 = 20$, so that R_1 , R_2 can be $38K\Omega$ and $2K\Omega$ respectively. If only an impedance match is needed, i.e., if a 0-10 volt source is available, but cannot deliver 1 mA of control current, R_1 can be replaced by a short circuit and the preamplifier operates as a voltage-follower.

3-55 PROCEDURE, VOLTAGE CONTROL WITH A HIGH IMPEDANCE CONTROL SOURCE

- 1) Connect the external components, the LOAD and the PRECISION VOLTMETER (M1) to the ATE as shown in FIG. 3-10.
- 2) With the EXT. CONTROL SOURCE at zero, turn the ATE "on".
- 3) Vary the EXT. CONTROL SOURCE from zero to its maximum output level. The ATE output voltage, as read out on M1, should vary from approximately zero volts to its rated maximum value. Return the EXT. CONTROL SOURCE to its zero position.

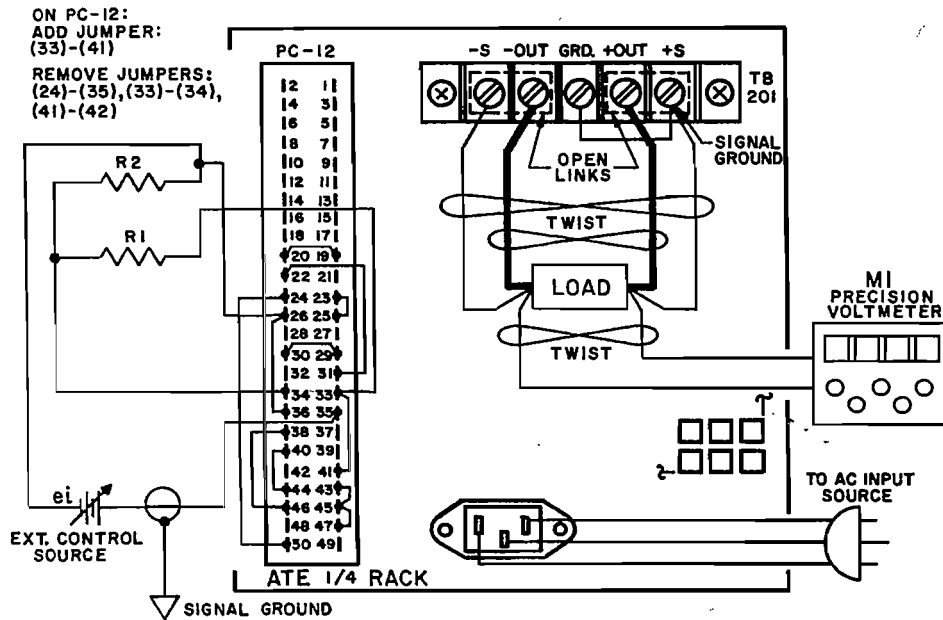

FIG. 3-10 CONNECTIONS FOR VOLTAGE CONTROL WITH A HIGH IMPEDANCE INPUT SOURCE.

3-56 CALIBRATION (Refer to Section II, FIG. 2-1 for the location of *all* internal controls).

- 1) Check the PRECISION VOLTMETER (M1) for "zero" reading and correct, if necessary, with the PREAMP "A" ZERO control.
- 2) Set EXT. CONTROL SOURCE to maximum output. Observe M1 and calibrate the ATE output voltage to the exact maximum rated value by adjusting the Calibrating Control in the EXT. CONTROL SOURCE.
- 3) Set EXT. CONTROL SOURCE to zero again, re-check the previously calibrated zero point on M1 and correct with the PREAMP "A" ZERO control if required.
- 4) Set the ATE front panel CURRENT CONTROL according to the LOAD requirements, following the procedure given in PAR. 3-28 (2,3,4,5), or use one of the output current programming circuits for remote control of the output current as described in PAR.'s 3-60 or 3-64. Set the overvoltage protector as described in PAR. 3-31.
- 5) Operation can now proceed. Check the ATE power supply output, by means of an oscilloscope, for dynamic stability and output ripple amplitude. Refer to PAR. 3-6 if high ripple is present. If the power supply output is dynamically unstable (oscillations) review the paragraphs on power supply/load interface and grounding (PAR.'s 3-6 through 3-26). Adjust the E_0 LAG control, if the ATE is configured for fast mode.

3-57 PROGRAMMING THE CURRENT CONTROL CHANNEL

3-58 GENERAL. The ATE output current, controlled by a front panel CURRENT CONTROL rheostat in the local control mode, can be remotely controlled by disconnecting the 15V bias from the non-inverting input of the EXT. CURRENT COMPARISON AMPL at the REAR PROGRAMMING CONNECTOR, and applying a 0 to 1 volt external control signal with reference to the ATE COMMON terminal. Since the non-inverting input of the EXT. CURRENT COMPARISON AMPL is used, only the small amplifier bias current must be supplied by the external control source. IN ALL CURRENT PROGRAMMING APPLICATIONS, THE FRONT PANEL CURRENT CONTROL SETTING OF THE ATE ACTS AS A "BACK-UP" CURRENT LIMIT AND MUST BE SET SLIGHTLY HIGHER THAN THE REQUIRED MAXIMUM OUTPUT CURRENT. An application, demonstrating this control method is described in PAR. 3-60 and illustrated in FIG. 3-11.

3-59 If the available programming source does not have the required amplitude or polarity, one of the ATE's uncommitted preamplifiers may be used to scale the programming source to the required control potential (0 to 1 volt), or provide the correct polarity. Typical examples of some possible applications are provided in the following paragraphs.

3-60 OUTPUT CURRENT CONTROL WITH AN EXTERNAL 0 TO 1V CONTROL SIGNAL

3-61 An interesting example of direct drive method is the control of the ATE output current by means of a Kepco SN-488 Digital Programmer. The SN-488 responds to digital input signals, is IEEE-488 bus compatible and can be addressed either by a computer or manually by means of a keyboard. The attenuated output signal of the SN-488 is a voltage from zero to 1 volt and constitutes the input program for the ATE current channel. Since the SN-488 has two independent outputs (A, B) and only one is needed for current control, the other output may be used to control the ATE output voltage (See par. 3-41).

3-62 PROCEDURE (OUTPUT CURRENT CONTROL WITH AN EXTERNAL 0-1 VOLT, D-C CONTROL SIGNAL)

- 1) Connect the EXT. CONTROL VOLTAGE, (Model SN-488 Digital Programmer), the LOAD and the PRECISION VOLTMETER (M1) to the ATE as shown in FIG. 3-11.

Note: The output current value can be measured directly by means of a suitable ammeter in series with the load or, as indicated in FIG. 3-11, indirectly by means of the precision voltmeter (M1) across a current measuring resistor (R_M). R_M should be selected such that a convenient range on the precision voltmeter can be used, e.g., for a 10 ampere output current, use a 0.1 ohm, resistor to produce a one volt full scale reading. If an electronic voltmeter is used, it should be batter-operated to avoid ground loops.

- 2) With the SN-488 output at zero, turn the ATE "on".
- 3) Vary the input voltage from the SN-488 from zero to 1 volt. The ATE output current, as read-out on M1, should vary from approximately zero volts to its maximum rated value. Return the SN-488 output to zero volts.

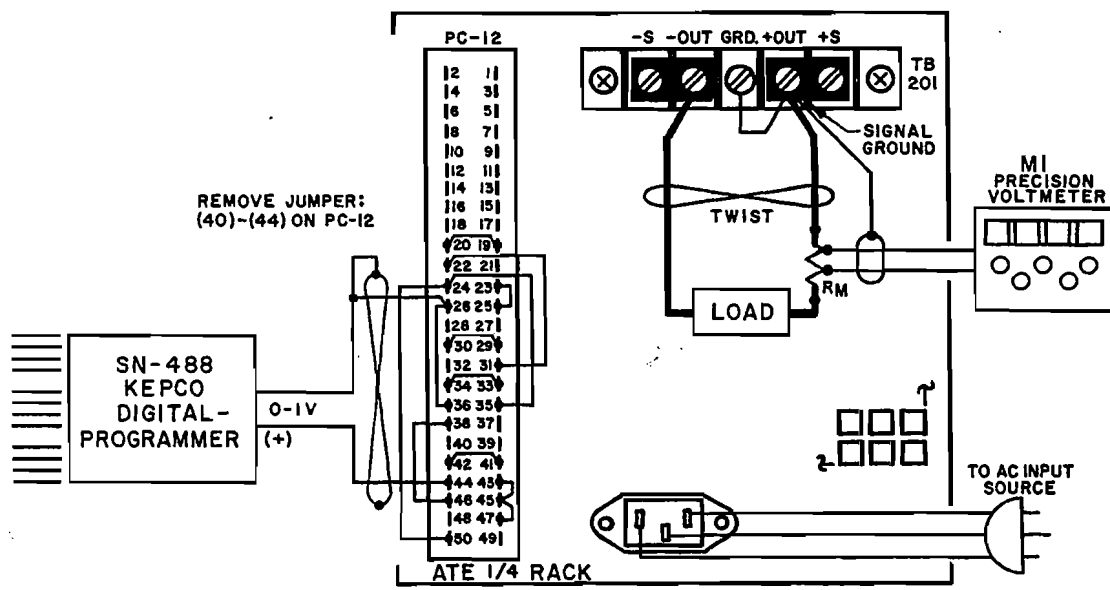

FIG. 3-11 CONNECTIONS FOR OUTPUT CURRENT CONTROL WITH A 0-1 VOLT CONTROL SIGNAL (KEPCO SN-488 DIGITAL PROGRAMMER).

3-63 CALIBRATION (Refer to Section II, FIG. 2-1 for the location of all internal controls).

- 1) Check the PRECISION VOLTMETER (M1) "zero" reading and correct, if necessary, with the ATE I_O ZERO control.
- 2) Set the Model SN-488 output to 1 volt. Observe M1 and calibrate the ATE output current to the exact maximum rated output current by means of the SN-488 calibration control.
- 3) Set the Model SN-488 output to "zero" again and check the previously calibrated zero point on M1. Correct with the ATE I_O ZERO control if required.
- 4) Set the ATE front panel VOLTAGE CONTROL according to your load requirements, or use one of the output VOLTAGE programming circuits for remote control of the output VOLTAGE as described in PAR's 3-37 through 3-56.

3-64 OUTPUT CURRENT CONTROL WITH A TWO-TERMINAL RESISTANCE

3-65 In this control mode, one of the ATE's preamplifiers is used in conjunction with one of the ATE's reference source, to produce the 0 to 1 volt control signal. The external feedback resistor (R_{CC}) serves as the two-terminal external current control.

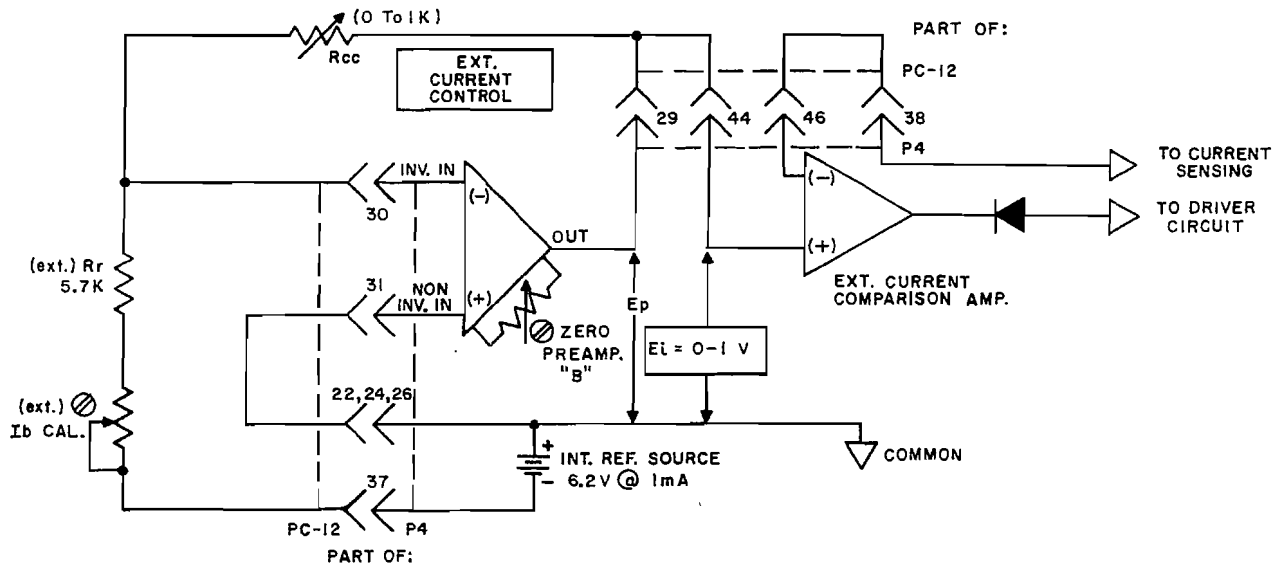

FIG. 3-12 TWO-TERMINAL RESISTANCE PROGRAMMING OF THE CURRENT CHANNEL USING THE PREAMPL AND THE INTERNAL REFERENCE SOURCE.

3-66 (Refer to FIG. 3-12). The preamplifier functions here in the inverting configuration, producing its output voltage (E_p , which is made equal to the required voltage " E_i ") according to the equation:

$$E_i = E_p = \frac{E_{ref}}{R_r} \times R_f \quad (\text{Eq. 1}),$$

where:

- R_r = Ext. Reference resistor
- E_p = Preamplifier output voltage equal to the required drive voltage (E_i)
- E_{ref} = Internal Reference Voltage 6.2V
- R_{cc} = Ext. Feedback Resistor (Current Control)

Since the ratio E_{ref}/R_r may be expressed as a control current: ($E_{ref}/R_r = I_b$), Eq. 1 can be simplified to read:

$$E_i = E_p = I_b R_f \quad (\text{Eq. 2})$$

3-67 If I_b is selected to be 1 mA for example (control current from approximately 0.1 to 1 mA can be selected), a 0 to 1K ohm, rheostat, decade or other variable resistance will produce the required 0-1 volt control potential and thereby control the ATE output current from zero to its maximum rated value. If a 0-1K ohm voltage control resistance is *not* available, the control current (I_b) can be changed to accommodate the available resistance value, making use of the preamplifier output equation (Eq. 2). If, for example, a 1.5K ohm precision potentiometer is available, the control current (I_b) must be: $1V/1.5K\Omega = 0.66$ mA. Since the built-in INT. REF. SOURCE is a (nominal) 6.2 volt, the external R_r must be: $6.2V/0.66$ mA $\approx 9.4K\Omega$ which can be made up from a $8K\Omega$ fixed, and a $2K\Omega$ trim resistor (I_b CAL.).

3-68 PROCEDURE, ATE OUTPUT CURRENT CONTROL WITH A TWO-TERMINAL RESISTANCE.

- 1) Connect the external components, the LOAD and the PRECISION VOLTMETER (M1) to the ATE as shown in FIG. 3-13. NOTE: The output current value can be measured directly by means of a suitable ammeter in series with the load or, as indicated in FIG. 3-13, indirectly by means of the precision voltmeter (M1) across a current measuring resistor (R_M). R_M should be selected such that a convenient range on the precision voltmeter can be used, e.g., for a 10 ampere output current, use a 0.1 ohm resistor to produce one volt full scale. If an electronic voltmeter is used, it should be battery operated to avoid ground loops.
- 2) With the EXT. CURRENT CONTROL at zero ohms, turn the ATE "on".
- 3) Vary the EXT. CURRENT CONTROL from zero ohms to its maximum resistance. The ATE output current, as read out on M1, should vary from approximately zero to its maximum value. Return the EXT. CURRENT CONTROL to its zero ohm position.

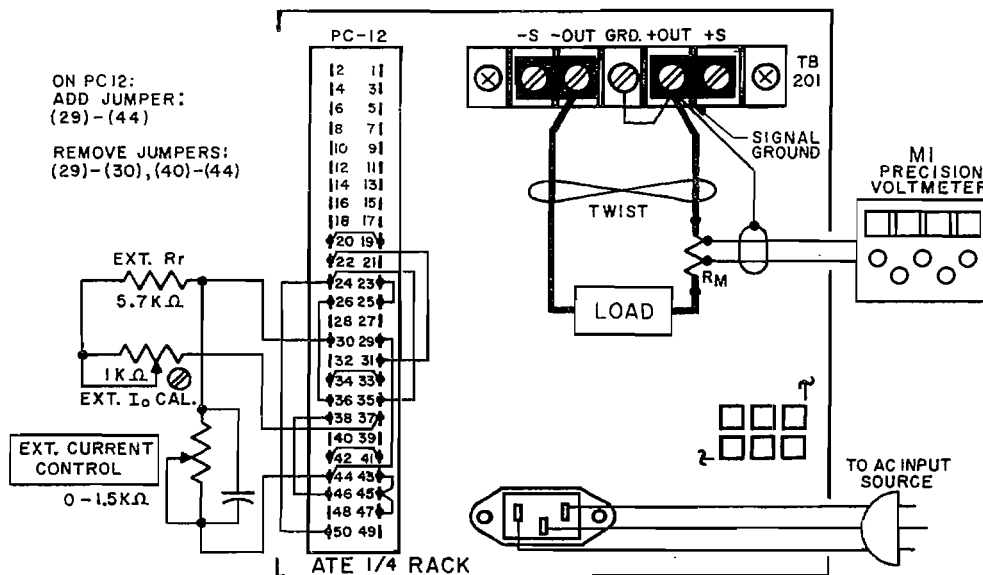

FIG. 3-13 CONNECTIONS FOR ATE OUTPUT CURRENT CONTROL WITH A TWO-TERMINAL RESISTANCE.

3-69 CALIBRATION (Refer to Section II, FIG. 2-1 for the location of *all* internal controls).

- 1) Check the PRECISION VOLTMETER (M1) for "zero" reading and correct, if necessary, with the PREAMP "B" ZERO CONTROL.
- 2) Set EXT. CURRENT CONTROL to its maximum resistance. Observe M1 and calibrate the ATE output current to the exact maximum rated value by adjusting the EXT. I_o CAL. control.
- 3) Set EXT. CURRENT CONTROL to zero ohms again, re-check the previously calibrated zero point on M1 and correct with the PREAMP "B" ZERO control if required.
- 4) Set the ATE front panel VOLTAGE CONTROL according to the LOAD requirements, or use one of the output Voltage programming circuits for remote control as described in PAR's 3-37 through 3-56.
- 5) Operation can now proceed. Check the output, by means of an oscilloscope across R_M , for dynamic stability and output ripple amplitude. Refer to PAR. 3-6 if high ripple is present. If the power supply output is dynamically unstable (oscillations), review the paragraphs on power supply/load interface and grounding PAR's 3-5 through 3-26).

3-70 PROGRAMMING THE OVERVOLTAGE PROTECTOR

3-71 The ATE overvoltage protector "crowbar level" is normally set by a front panel (screwdriver adjusted) control (SET LEVEL). This local operating mode has been previously described in PAR. 3-31. The crowbar level can be independently remotely controlled by setting the internal crowbar level to zero, turning the front panel SET LEVEL control completely counterclockwise and applying an external control signal (0 to 10V d-c) at the OVERVOLTAGE INPUT. In another programming mode, the crowbar level can be controlled in a "tracking mode", i.e., the 0–10 volt output voltage programming signal can simultaneously be applied to the overvoltage protector, so that the crowbar level automatically "tracks" the output voltage level of the ATE. Typical examples of these programming applications are presented in the following paragraphs.

3-72 REMOTE CROWBAR LEVEL CONTROL WITH AN EXTERNAL (0–10 VOLT D-C, 1 mA) SIGNAL

3-73 The ATE crowbar level can be remotely controlled by an external 0 to 10 volt, 1 mA d-c control source. One example of such a control source is the Kepco SN–488 Digital Programmer, which responds to digital input signals and can be controlled by computer or manually. The output of the SN–488 is from zero to 10 volts or 0 to 1 volt per channel and serves as the input to the ATE overvoltage protector.

3-74 PROCEDURE, CROWBAR LEVEL CONTROL WITH AN EXTERNAL SIGNAL

- 1) Turn front CROWBAR SET LEVEL completely counterclockwise.
- 2) Connect a substitute LOAD and the EXT. CONTROL SOURCE to the ATE as shown in FIG. 3-14. Set the EXT. CONTROL SOURCE to its maximum value.
- 3) Turn the ATE "on" and adjust the front panel VOLTAGE CONTROL to the desired *crowbar level*, i.e., the level at which the ATE is to shut down, *not* to your load voltage level.
NOTE: Monitor the power supply voltage either by means of the front panel meter, or if required, connect a precision voltmeter across the load.
- 4) Slowly reduce the level of the EXT. CONTROL SOURCE and note if the ATE shuts down at the correct crowbar level.
- 5) Turn the ATE front panel VOLTAGE CONTROL one turn counterclockwise and re-activate the ATE circuit breaker.
- 6) Test the previously set crowbar level again by turning the front panel VOLTAGE CONTROL slowly counterclockwise and observing the voltmeter. If the ATE does not shut down at the intended crowbar level, correct the setting of the EXT. CONTROL SOURCE, turn front panel VOLTAGE CONTROL one turn counterclockwise, re-activate the ATE circuit breaker and test again.
- 7) Turn the ATE front panel VOLTAGE CONTROL to the *exact* operating voltage which the LOAD requires.

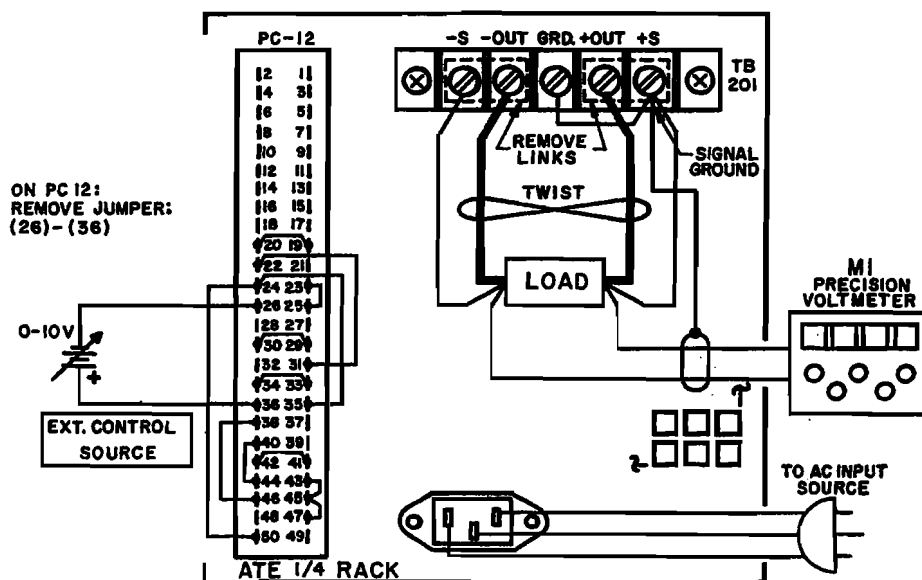

FIG. 3-14 REMOTE CROWBAR LEVEL CONTROL WITH AN EXTERNAL (0–10V D-C @ 1 mA) SIGNAL SOURCE.

3-75 AUTOMATIC (TRACKING) CONTROL OF THE CROWBAR LEVEL

3-76 In this application, an ATE's voltage output is remotely controlled by a 0-10 volt external programming signal which is simultaneously applied as a control signal to the overvoltage protector. As the ATE output voltage is now programmed by the external programming source throughout the specified range of the ATE, the crowbar level is "tracking" the output voltage, i.e., it always remains higher than the instantaneous ATE output voltage, thus providing automatic overvoltage protection throughout the range.

3-77 PROCEDURE, AUTOMATIC (TRACKING) CONTROL OF THE CROWBAR LEVEL, (ATE IN "SLOW" MODE)⁽¹⁾

- 1) Connect jumpers on the REAR PROGRAMMING CONNECTOR as indicated in FIG. 3-15 and connect switch (S1) as shown. Turn front panel CROWBAR LEVEL control fully counterclockwise.
- 2) Connect a substitute LOAD and the EXT. PROGRAMMING SOURCE as shown in FIG. 3-15.
- 3) To test the overvoltage protector action, turn ATE "on" and set output voltage by means of the EXT. PROGRAMMING SOURCE to a nominal value. Switch S1 from position A to B. The overvoltage protector will crowbar the ATE output. The CROWBAR indicator will be "on" momentarily and the ATE circuit breaker will trip.
- 4) Remove S1, and connect a jumper between (41)-(50) of PC-12. Connect the actual LOAD, reactivate the ATE circuit breaker and commence operation. Should erratic triggering occur in actual operation, set front panel CROWBAR LEVEL control slightly clockwise. This will increase the "threshold" voltage; that is, the difference voltage between the crowbar level and the operating voltage.

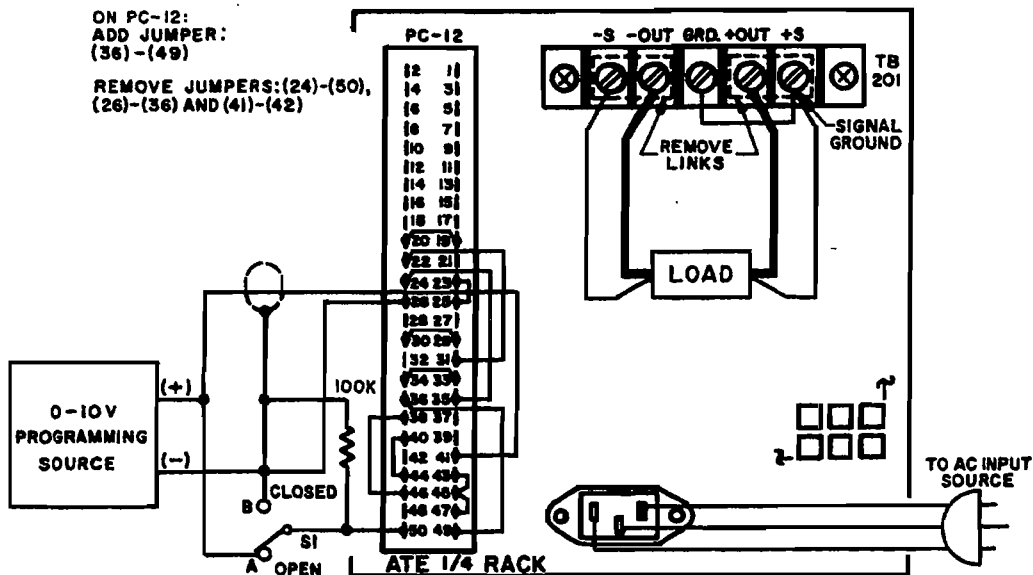

FIG. 3-15 CONNECTIONS FOR SIMULTANEOUSLY PROGRAMMING THE ATE OUTPUT VOLTAGE AND THE CROWBAR LEVEL (AUTOMATIC TRACKING).

⁽¹⁾ If the ATE is operated in the "FAST" mode, the following connections to PC-12 must be changed:

- 1) Do not add jumper (36)-(49)
 - 2) Do not remove jumper (24)-(50)
 - 3) Connect S1-Common and 100K to pin 36
 - 4) In paragraph, 3-77 Step 4, connect pins (36) and (41)
- All other descriptions are applicable for both, "FAST" and "SLOW" operating mode.

3-78 PROGRAMMING THE OUTPUT VOLTAGE AND THE OUTPUT CURRENT SIMULTANEOUSLY BY MEANS OF EXTERNAL, REMOTE CONTROL VOLTAGES

3-79 The output voltage, and the output current of the ATE power supply can be controlled simultaneously by means of remotely located variable voltage sources. The control voltages required to drive the voltage and current channels over the rated output range are 0 to 10 volt at 1 mA for the Voltage Channel and 0 to 1 volt for the Current Channel. An ideal programming source is the Kepco SN-488 Digital Programming System, which provides two independent control voltages of the correct magnitude per programming card.

NOTE: FOR CONTROL SOURCES NOT WITHIN THE GIVEN SPECIFICATIONS, THE TWO PREAMPLIFIERS MAY BE USED, AS DESCRIBED IN PAR.'S 3-45 TO 3-56 AND 3-64 TO 3-69, TO SCALE THE AVAILABLE CONTROL VOLTAGE UP OR DOWN AS REQUIRED.

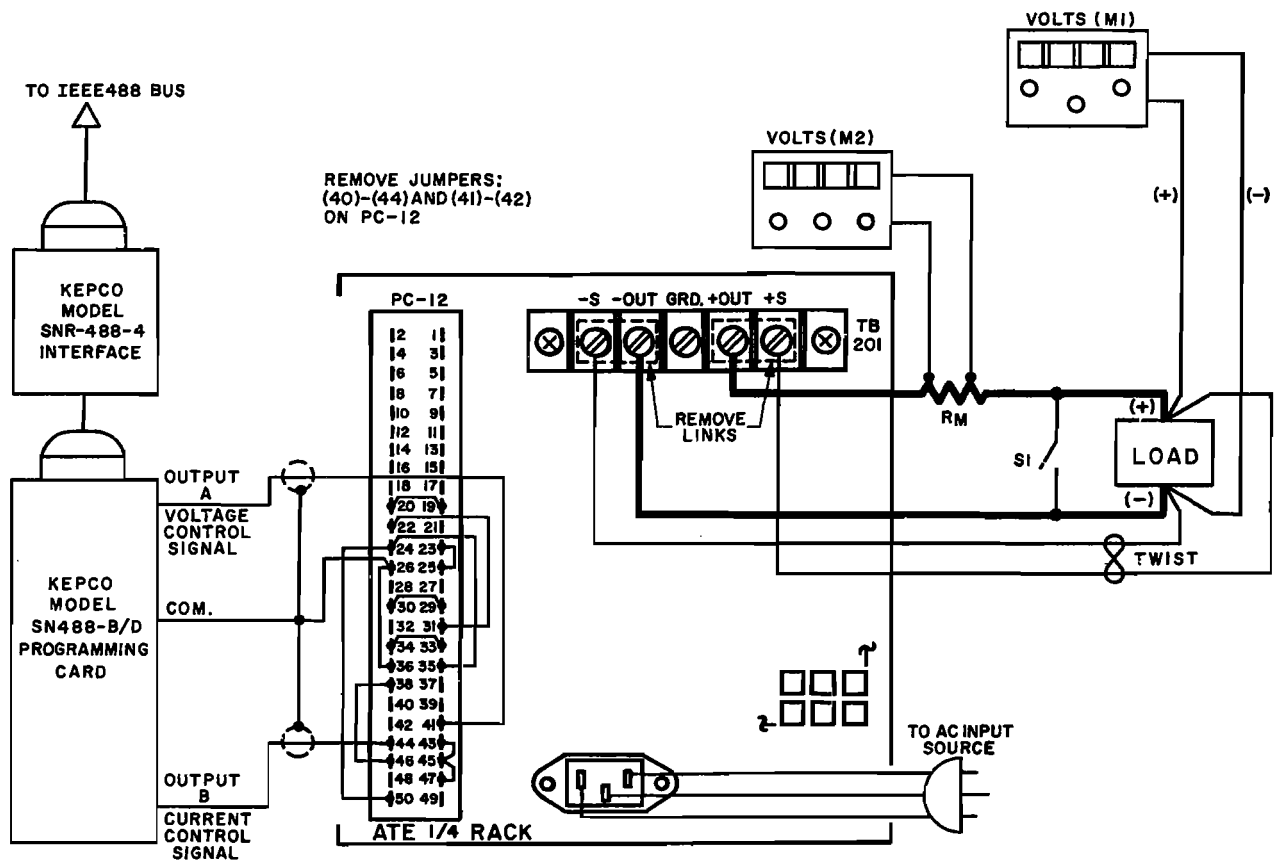

FIG. 3-16 CONNECTIONS FOR CONTROL OF OUTPUT VOLTAGE AND OUTPUT CURRENT BY MEANS OF EXTERNAL, VARIABLE CONTROL VOLTAGES, SUPPLIED BY THE KEPCO SN-488 DIGITAL PROGRAMMING SYSTEM.

3-80 PROCEDURE, OUTPUT CONTROL WITH EXTERNAL CONTROL VOLTAGES, SUPPLIED BY THE KEPCO SN-488

STEP 1: Connect external components, the LOAD, the PRECISION VOLTMETERS and the R_M as shown in FIG. 3-16.

STEP 2: With the VOLTAGE CONTROL SIGNAL (Channel A) at some non-zero value and the CURRENT CONTROL SIGNAL (Channel B) at zero, turn power supply "on".

STEP 3: Close S1. Vary the CURRENT CONTROL SIGNAL from zero to its maximum value. The power supply output current, as read-out on M2, should vary from approximately zero to the rated maximum output current. Leave CURRENT CONTROL SIGNAL at its maximum setting.

STEP 4: Open S1. Vary the VOLTAGE CONTROL SIGNAL from its initial setting to its maximum value. The output voltage, as read-out on M1, should vary from approximately zero to the rated maximum output voltage.

3-81 CALIBRATION, VOLTAGE CHANNEL

(Refer to Section II, FIG. 2-1 for the location of all internal power supply controls).

(Refer to your SN-488 system manual for the location of the system calibration controls).

- 1) Open S1. Set VOLTAGE CONTROL SIGNAL to zero. Check the PRECISION VOLTMETER (M1) for "zero" reading and correct, if necessary, with the "E₀ ZERO" control.
- 2) Set VOLTAGE CONTROL SIGNAL to its maximum value. Observe M1 and calibrate the power supply output voltage to the exact maximum rated value by adjusting the external control voltage (Channel A, full-scale cal. control).
- 3) Set VOLTAGE CONTROL SIGNAL to zero again, re-check the previously calibrated zero point on M1 and correct with the power supply "E₀ ZERO" control if required.
- 4) This concludes the calibration of the voltage channel. Leave the VOLTAGE CONTROL SIGNAL at approximately 1/3 its maximum setting.

3-82 CALIBRATION, CURRENT CHANNEL

Note: The output current value can be measured directly by means of a suitable ammeter in series with the load or, as indicated in FIG. 3-16, indirectly by means of the precision voltmeter (M1) across a current measuring resistor (R_M). R_M should be selected such that a convenient range on the precision voltmeter can be used, e.g., for one ampere output current, use a 0.1 ohm resistor to produce 100mV full scale. If an electronic voltmeter is used, it should be battery-operated to avoid ground loops.

- 1) Close S1. Set CURRENT CONTROL SIGNAL to zero. Check the PRECISION VOLTMETER (M2) for "zero" reading and correct, if necessary, with the power supply "I₀ ZERO" control.
- 2) Set CURRENT CONTROL SIGNAL to its maximum value. Observe M2 and calibrate the power supply output current to the exact maximum rated value by adjusting the external control voltage (Channel B, full-scale cal. control).
- 3) Set CURRENT CONTROL SIGNAL to zero again, re-check the previously calibrated zero point on M2 and correct with the power supply "I₀ ZERO" control if required. Open S1.

3-83 Operation can now proceed. Check the output, by means of an oscilloscope, for dynamic stability and output ripple amplitude. Refer to PAR. 3-6 if high ripple is present. If the power supply output is dynamically unstable (oscillations) review the paragraphs on power supply/load interface and grounding (PAR's 3-6 through 3-26).

3-84 THE USE OF THE "EXT. CURRENT COMPARISON AMPLIFIER" FOR GENERAL FEEDBACK CONTROL

3-85 The output of the ATE power supply is normally controlled either by the VOLTAGE COMPARISON, or by the INT. CURRENT COMPARISON AMPLIFIER, depending on the prevailing operating mode. A glance at the SIMPLIFIED SCHEMATIC DIAGRAM (See end of Section III), however, shows that a third control channel is available, via the EXT. CURRENT COMPARISON AMPLIFIER, which is normally "biased off". The use of this amplifier has previously been shown in an application for external current control (See par.'s 3-57 to 3-63. Since both inputs of the EXT. CURRENT COMPARISON AMPLIFIER are available at the REAR PROGRAMMING CONNECTOR (PC-12), it can be used advantageously to control the power supply output in response to feedback from such diverse physical phenomena as light, temperature, pressure, chemical reactions and the like. Since the (open loop) gain of this third control channel is very high, only minute feedback signals in combination with an appropriate external control are required.

3-86 The design of the required external circuitry is shown by means of the following example: A "target" object requires constant illumination, supplied by a lamp, which is connected at the power supply output. The feedback is supplied by a photo cell, the output of which is 0-100mV, depending on the light input. A "Brightness Control" is required to adjust various illumination levels.

Note: Depending upon the characteristics of both, lamp and photo-cell, fast mode operation of the ATE might be advisable.

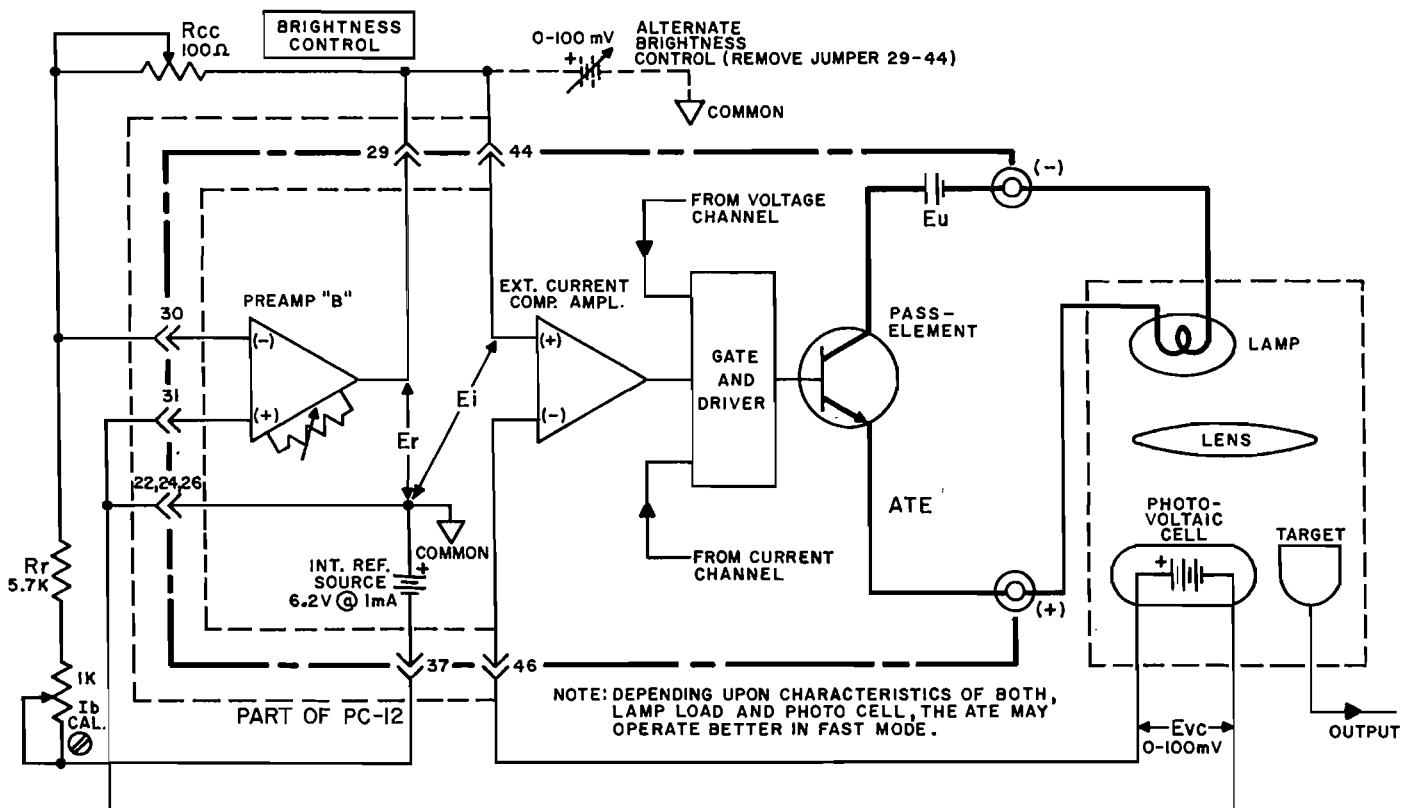

FIG. 3-17 ILLUMINATION CONTROL CIRCUIT WITH THE ATE POWER SUPPLY.

3-87 (Refer to FIG. 3-17). Assuming the ATE power supply is compatible with the requirements of the lamp load, the control circuit may be designed as shown with one of the ATE preamplifiers, or, an external control voltage source can be connected as indicated with the dashed lines in FIG. 3-17. The external source should be adjustable in the range from 0 to 100mV if illumination control is desired, or it should have a means of calibration if a fixed external source is used for a constant illumination level.

3-88 In the example, the ATE internal preamplifier (PREAMPL "B") is used to develop the control signal ($E_i = 0-100mV$), which is compared with the photo-cell output at the input to the EXT. CURRENT COMPARISON AMPLIFIER. The external reference resistor (R_r) and the control rheostat (R_{cc}) are selected to produce the control signal, similar to the example described in a previous application (See par. 3-64).

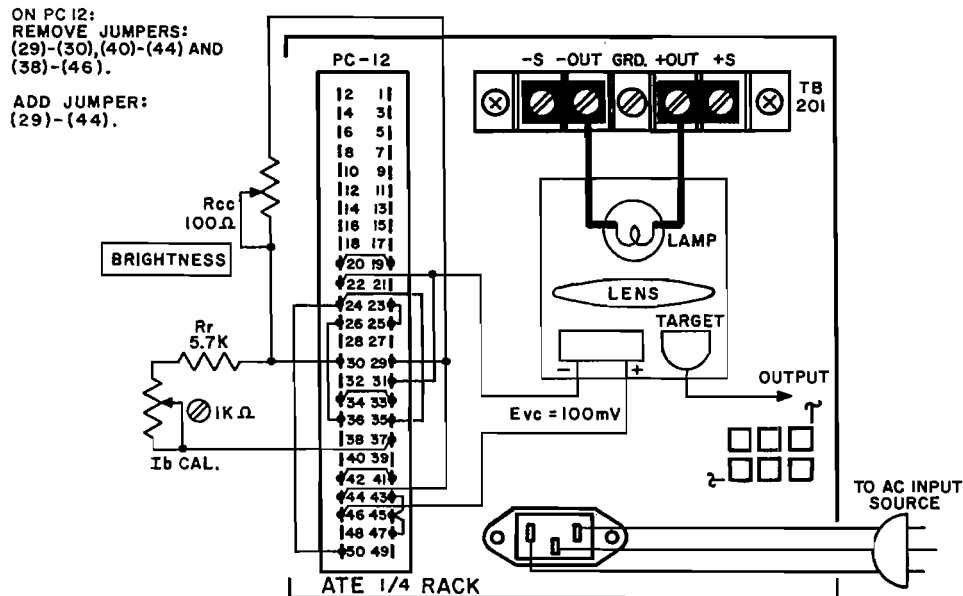

FIG. 3-18 CONNECTIONS FOR ILLUMINATION CONTROL, USING THE EXT. CURRENT COMPARISON AMPL.

3-89 PROCEDURE, ILLUMINATION CONTROL

- 1) Connect the external components to the ATE power supply as shown in FIG. 3-18.
- 2) Adjust both, ATE front panel VOLTAGE and CURRENT CONTROLS approximately 10% beyond the values required by the LAMP which represents the power supply load. Although the voltage or current channel are not in control in this application, the setting of the front panel output controls close to the lamp requirements serve as a "back-up" voltage and current limit should feedback control from the photo-cell be lost.
- 3) Turn the external BRIGHTNESS CONTROL to its mid-range and turn the ATE power supply "on". Vary the BRIGHTNESS CONTROL through its range and observe its effect on the LAMP. The lamp brightness should vary from zero (dark) to the approximate maximum brightness.

3-90 CALIBRATION

Turn the BRIGHTNESS CONTROL (R_{CC}) to its maximum clockwise position and adjust the external I_b CAL. control until the maximum desired brightness is measured.

3-91 MULTIPLE POWER SUPPLY AND SYSTEMS OPERATION

- 3-92 In applications where several power supplies are used it is often necessary to shut down *all* power supplies if a malfunction on a *single* supply forces its shut-down. Sometimes, a "PANIC BUTTON" arrangement is desired, where *all* system power supplies can be shut-down with a single manual switch or a common signal from a controller. ATE power supplies are ideally suited for multi-unit operation since all necessary crowbar control circuit connections are terminated at the rear PROGRAMMING CONNECTOR (PC-12). The crowbar control connections in a multi-unit application can be externally wired to form a closed loop fault-detection circuit as shown in FIG. 3-19. Although only three ATE power supplies are shown, the control loop may be extended to include as many ATE power supplies as are required.

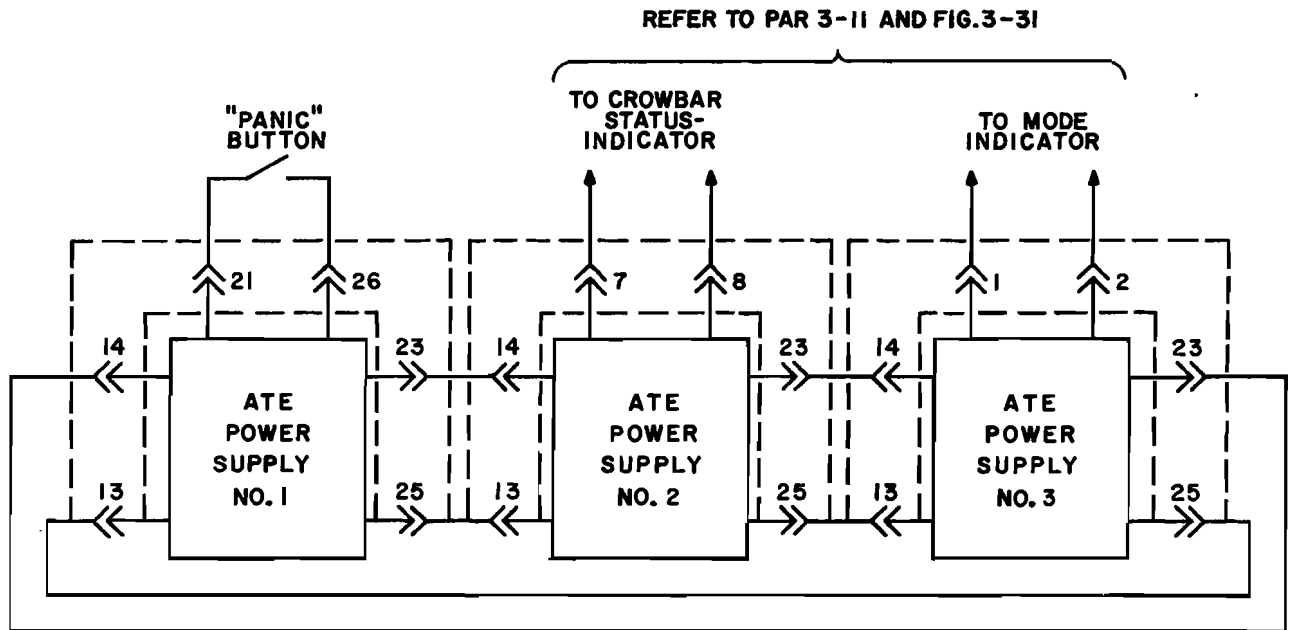

FIG. 3-19 MULTIPLE POWER SUPPLY FAULT DETECTION LOOP

3-93 In addition to the crowbar terminals, optically isolated flag signals are available at the PROGRAMMING CONNECTOR (PC-12) of each ATE power supply. These signals may be used to indicate the crowbar status and the operating mode of each ATE power supply (See FIG. 3-19).

3-94 SERIES CONNECTION OF ATE POWER SUPPLIES

3-95 Kepco ATE power supplies may be connected in series for increased voltage output. Series connection of *two* ATE units is described here, but several units, up to an output voltage total of 500 volts may be inter-connected. Two basic methods of series connection are commonly used: The "AUTOMATIC" and the "MASTER/SLAVE" configuration. The choice between these two methods will depend on the application at hand. If individual power supply control is desired, the "Automatic" series connection should be used. If the output of the interconnected power supplies is to be controlled simultaneously, the "MASTER/SLAVE" method is recommended. For *either* method, some general rules should be remembered:

- 1) Series - connect supplies *only* up to a total of 500 volts output voltage, this is the isolation voltage limit for the ATE power supply.
- 2) Series - connect supplies *only* if they have *similar current rating* or, if the current control can be adjusted to the same load current.
- 3) Use error-sensing, as shown in the diagram (See FIG. 3-20), to compensate for load-wire drops.

NOTE: SENSING LEADS ARE NOT REQUIRED IF THE APPLICATION CALLS FOR CURRENT MODE OPERATION EXCLUSIVELY.

- 4) The load-wires should be as short as practicable. Select the load-wires as heavy as possible and twist the load-wire pair tightly. Approximate equal lengths of load-wire between each pair of supplies is recommended.
- 5) Use the Fault Detection Loop, as described in par. 3-91.
- 6) All previously described programming circuits may be used on the MASTER power supply, to program the series connected system.

3-96 PROCEDURE, AUTOMATIC SERIES CONNECTION

- 1) Without connecting the power supplies to the load, turn a-c power "on", and adjust the output voltage on each supply to the required level (the sum of the output voltages will be the voltage applied to the load).
- 2) Adjust the current control on each power supply to its extreme counterclockwise position. Turn a-c power "off". Connect a short circuit consisting of a short wire across the output terminals of each power supply. Turn a-c power "on" and adjust each ATE Current Control to the required load current. Turn a-c power "off". Remove shorting wires from output terminals.
- 3) Make all load connections as shown in the diagram (refer to FIG. 3-20).
- 4) Turn a-c power "on". Observe output metering and front panel MODE indicators. The output current should be identical on all series connected supplies and all supplies should operate in the voltage mode (VOLTAGE MODE indicator "on").
- 5) On those supplies *not* operating in the voltage mode, turn current control slightly clockwise until the VOLTAGE MODE indicator energizes.
- 6) If current mode operation is desired turn one front panel current control slightly counterclockwise such that the CURRENT MODE indicator is just energizing (the remaining supply (supplies) should remain in the voltage mode of operation).

Operation can now proceed.

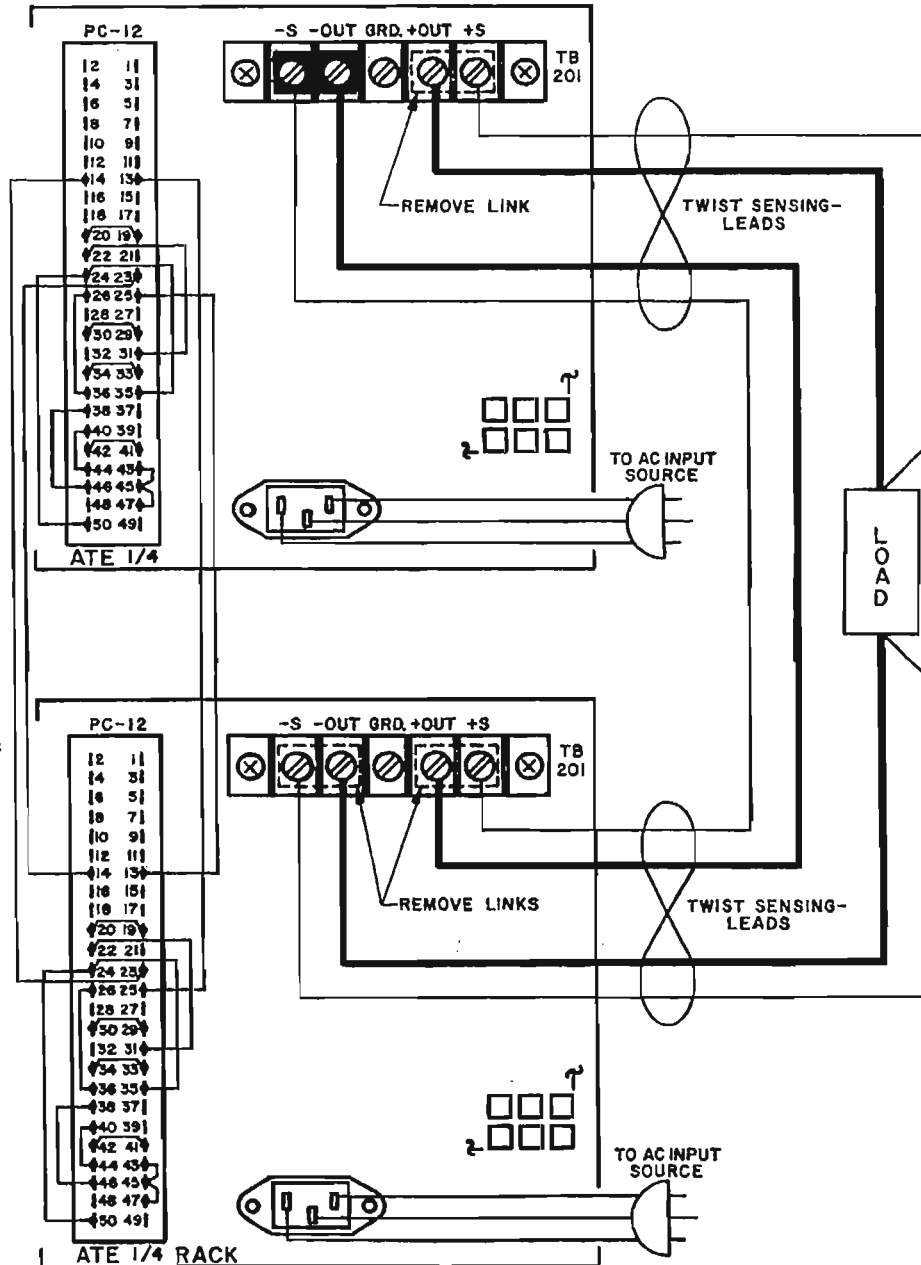

FIG. 3-20 AUTOMATIC SERIES CONNECTION

ON PC 12:
REMOVE JUMPERS:
(23)-(26) ON
ALL UNITS

- 3-97 **MASTER/SLAVE SERIES OPERATION.** In this mode of operation the total output voltage of all supplies in the series connection is controlled from a common "Master" supply, while the voltage output of the "Slave" supplies "follow" the output voltage of the "Master".
- 3-98 As seen from the diagram (FIG. 3-21) in each SLAVE supply, the input to the VOLTAGE COMPARISON AMP is disconnected from the output of the VOLTAGE CONTROL amplifier and an external drive signal is derived from the output voltage of the MASTER supply (E_{om}) and applied via a coupling resistor (R_t), to the SLAVE supply.

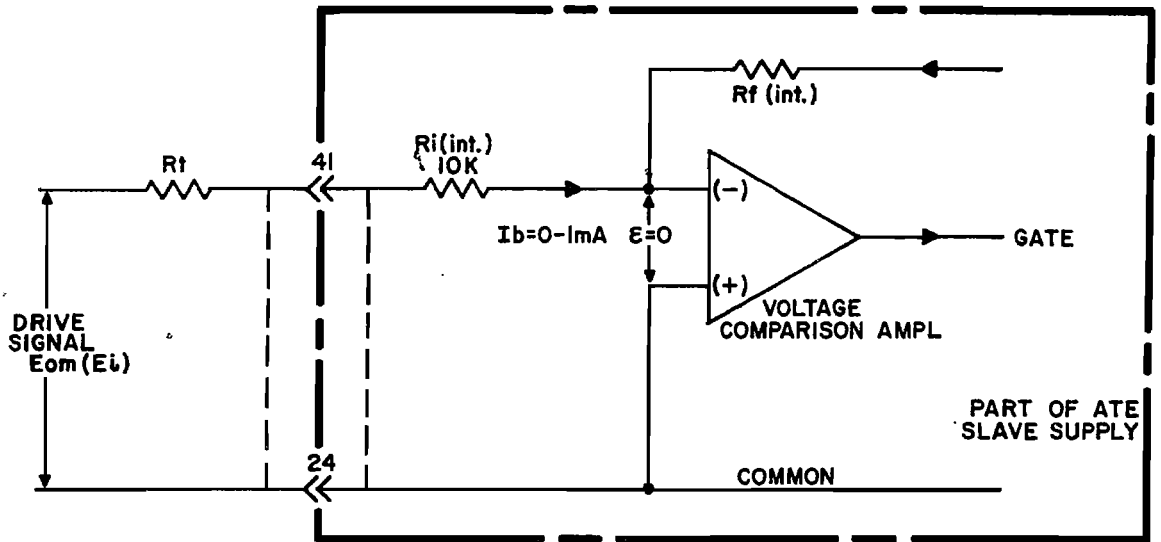

FIG. 3-21 DEVELOPING THE DRIVE FOR THE MASTER/SLAVE SERIES CONNECTION, ATE POWER SUPPLIES WITH RATED OUTPUT VOLTAGE > 6V.

- 3-99 The output voltage of each SLAVE supply (E_{os}) will be from 0 to its maximum rated output voltage if the input signal to its VOLTAGE COMPARISON AMP (E_i) is proportioned to produce a control current (I_b) of 1mA. Since the null junction voltage (E) equals zero at balance,

$$I_b = \frac{E_{om}}{R_t + R_i(\text{int})} \quad \text{or, } R_t = \frac{E_{om} - I_b R_i}{I_b} = \frac{E_{om}}{I_b} - R_i$$

Since $I_b = 1\text{mA}$, $R_i = 10\text{K ohm}$ in all ATE power supplies, R_t (K ohms) = $\frac{E_{om}}{1\text{mA}} - 10\text{K}$

For example, if a series connection of two ATE supplies with maximum output voltage of 36 and 55 volts is planned for an application requiring a voltage supply from 0 to 91 volts into a common load, the coupling resistor is selected as follows:

Let $E_{om} = 0-55\text{V}$ (MASTER SUPPLY), then the SLAVE SUPPLY (E_{os}) must vary from zero to 36 volts, as the MASTER supply is varied over its output voltage range. Calculating the coupling resistor.

$R_t = \frac{55\text{V}}{1\text{mA}} - 10\text{K} = 45\text{K ohms}$, and connecting the system as shown in FIG. 3-22 will produce the desired result.

3-100 PROCEDURE. MASTER/SLAVE SERIES OPERATION WITH TWO OR MORE ATE SUPPLIES

- 1) Connect each individual ATE power supply, to be connected in series, to the a-c power line. Adjust the front panel Current Control on each ATE completely counterclockwise. Connect a short-circuit, consisting of a short wire length across the output terminals of each ATE supply.
- 2) Turn a-c power "on" and adjust each ATE Current Control to the required load-current plus 5%. Turn a-c power "off", remove short circuit.
- 3) Interconnect power supplies as shown in FIG. 3-22. Note: Only one SLAVE unit is shown, but more can be added. Turn MASTER supply VOLTAGE CONTROL to its maximum counterclockwise position.
- 4) Turn a-c power "on". Observe front panel MODE INDICATORS. All "VOLTAGE MODE" indicators should be "on" and all front panel meters should read approximately zero.
- 5) Slowly, turn MASTER voltage control clockwise, until the desired output voltage level is reached. The load voltage is the sum of the MASTER and all SLAVE output voltage as read out on each front panel output voltage meter. All output current meters should read the identical load current.
- 6) Set the output current limit point by turning the current control on all series connected supplies counterclockwise, until each supply just transfers into the current mode CURRENT MODE indicator "on", then turn each slightly clockwise again, until each VOLTAGE MODE indicator energizes again.
- 7) If current mode operation is desired, leave the setting of the "Master" current control such that the CURRENT MODE indicator is energized. While the output current can now be controlled by the "Master" supply, the "Slave" supply will still operate in the voltage mode (VOLTAGE MODE indicator "on" and deliver additional compliance voltage to the load).

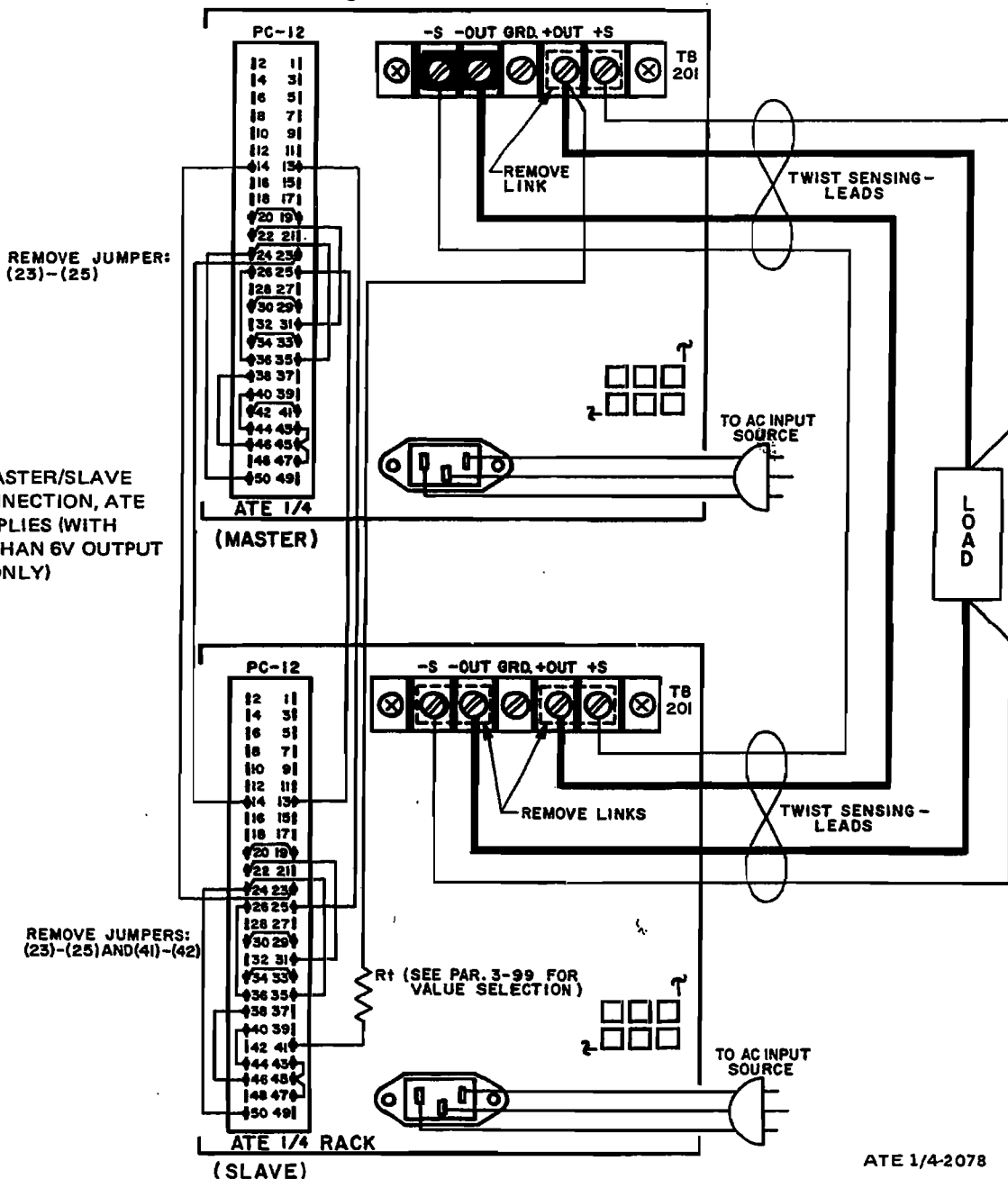

FIG. 3-22 MASTER/SLAVE SERIES CONNECTION, ATE POWER SUPPLIES (WITH GREATER THAN 6V OUTPUT VOLTAGE ONLY)

3-101 MASTER/SLAVE SERIES OPERATION WITH ATE 6V POWER SUPPLIES

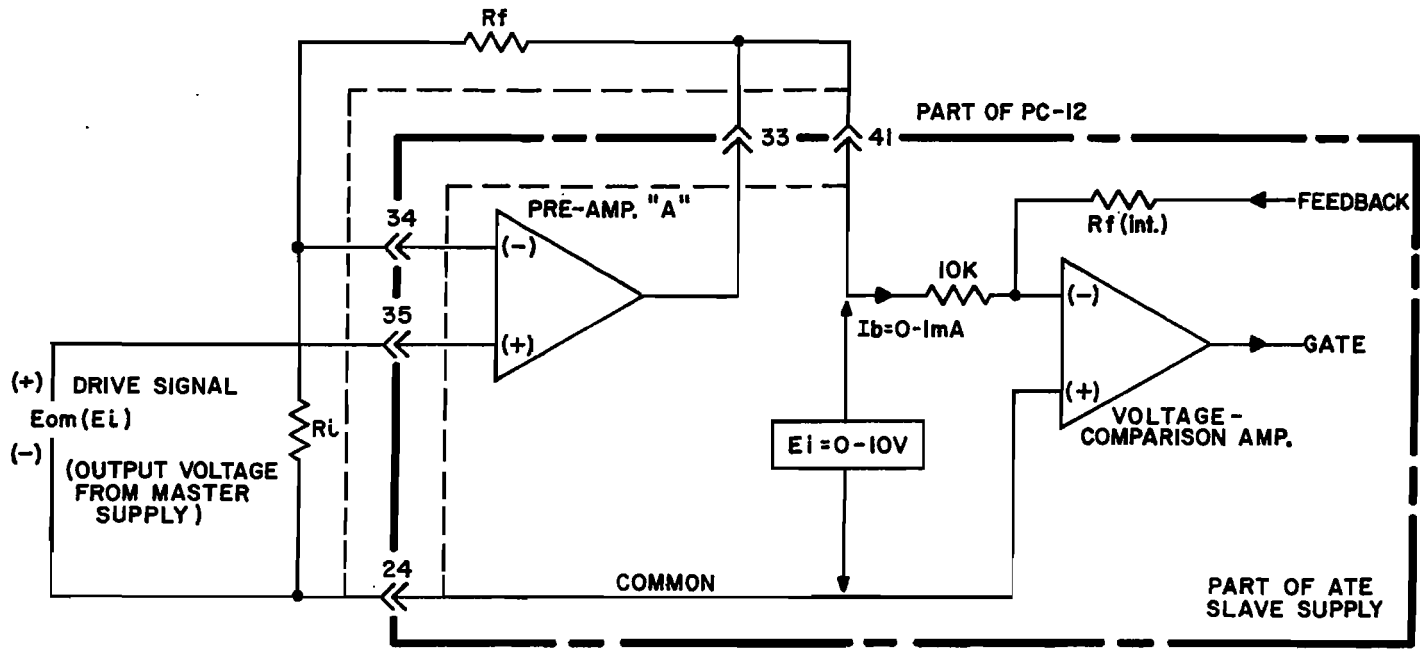

FIG. 3-23 DEVELOPING THE DRIVE FOR THE MASTER/SLAVE SERIES CONNECTION FOR 6V ATE SUPPLIES.

3-102 ATE power supplies with 6 volts maximum output voltage cannot be master/slave connected as described in par. 3-97. Instead, the MASTER output voltage (6V) must first be amplified to 10 volts if the SLAVE supply is to be driven through its full output voltage range. As seen from FIG. 3-23, one of the preamplifiers of the slave unit may be used to proportion the drive signal to the required level. For a 0–1mA control current (I_b) the input voltage (E_i) to the VOLTAGE COMPARISON AMP must be 0–10 volt. Therefore, the MASTER output voltage (E_{Om}) is amplified, using PREAMP "A", by selecting the value for the external resistors (R_f , R_i) accordingly. The values for these resistors are calculated on the basis of the equation: $E_{Out} \text{ (preamp)} = E_i = E_{Om} \times (R_f + R_i)/R_i$. For the example of two 6 volt ATE supplies in series connection: $E_{Om} = 6V$, therefore $(R_f + R_i)/R_i$ (the closed loop gain of PREAMP "A") must be $6 \times (R_f + R_i)/R_i = 10$ or $(R_f + R_i)/R_i \approx 1.7$. Letting $R_f = 3K$, R_i must be approximately 5K ohms. R_f may be selected to be a rheostat, so that a convenient gain control is available for calibration.

3-103 PARALLEL OPERATION OF ATE POWER SUPPLIES

3-104 Normally, crowbar equipped power supplies can not be connected in parallel, since a triggered crowbar in one supply, working in a parallel configuration, would present a short circuit to all other supplies and would have to absorb the total output current. In the ATE power supply, crowbar control circuitry is provided, allowing the setup of a fault-detection loop, which shuts off all power supplies in a parallel configuration if one power supply is "crowbared" for any reason.

3-105 As in the previously described "series" connections, an "Automatic" or a "Master/Slave" connection method can be chosen for paralleling ATE power supplies. The choice between the two methods will depend on the application at hand. For constant loads or small load variations (load changes smaller than the maximum output range of a single power supply), the "Automatic" parallel connection can be used. For load changes exceeding the maximum rating of a single power supply, the "Master/Slave" method is suitable. Both methods allow operation in the voltage or current mode. For either method, some general rules should be observed:

- 1) Parallel only supplies which can be adjusted to the same compliance (output) voltage.
- 2) Error sensing, as shown in the following diagrams, can be used to compensate for load wire voltage drops.
- 3) Load wires should be as short as practicable. Select wire gauge as heavy as possible and twist wires tightly. Approximately equal lengths of wire should be used.
- 4) Use the fault detection loop circuit, as described in par. 3-91.

NOTE: The diagram below (refer to FIG. 3-24) shows how the two power supplies operate in the automatic parallel mode. As seen from FIG. 3-24, load variations should be confined to the stabilization region of SUPPLY #2 since there is an initial adjustment error (ΔE_o) between the two supplies.

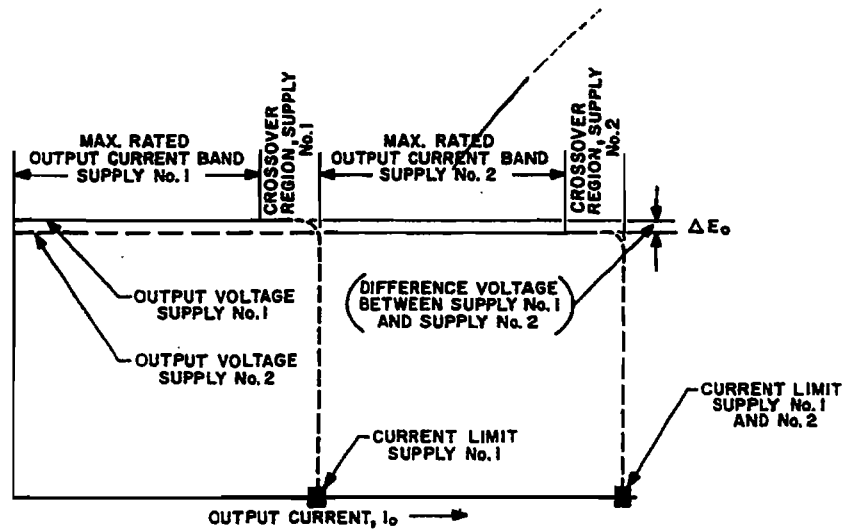

FIG. 3-24 "AUTOMATIC" PARALLEL OPERATION (TWO SUPPLIES).

3-106 If stabilized output current (rather than stabilized output voltage) is desired, all previous comments are valid, except that error sensing is not needed. For stabilized output current, the Current Control of the supply operating initially in the "voltage" mode (SUPPLY #2) is readjusted (counterclockwise) to such a value that SUPPLY #2 just switches to the "current" mode (observe front panel MODE indicators).

3-107 PROCEDURE, AUTOMATIC PARALLEL CONNECTION

Note: The parallel connection of two ATE power supplies is described, although more can be connected.

- 1) Without connecting the power supplies to the load or to each other, turn a-c power "on", and adjust the output voltage on each supply to the desired value.
- 2) Adjust both power supply current controls to their maximum (extreme clockwise) position. Turn a-c power "off".
- 3) Make all load interconnections as shown in the connection diagram (refer to FIG. 3-25).
- 4) Place the individual a-c power switches of the power supplies in the "on" position. Observe output current meters and mode lights on both units. Since the initial output voltage adjustments were not identical, one of the power supplies (to be designated SUPPLY #1), will be at a slightly higher output voltage than the other (to be designated SUPPLY #2). Consequently, SUPPLY #1 will deliver its maximum load current and will operate in the current mode, CURRENT MODE indicator "on". The rest of the load current is delivered by SUPPLY #2 which is operating in the voltage mode (VOLTAGE MODE indicator "on").
- 5) The Current Control of SUPPLY #1 can now be adjusted, as to equalize the total load current between SUPPLY #1 and SUPPLY #2, and operation can proceed.

ON PC-12:
REMOVE JUMPER:
(23)-(25) ON
ALL UNITS

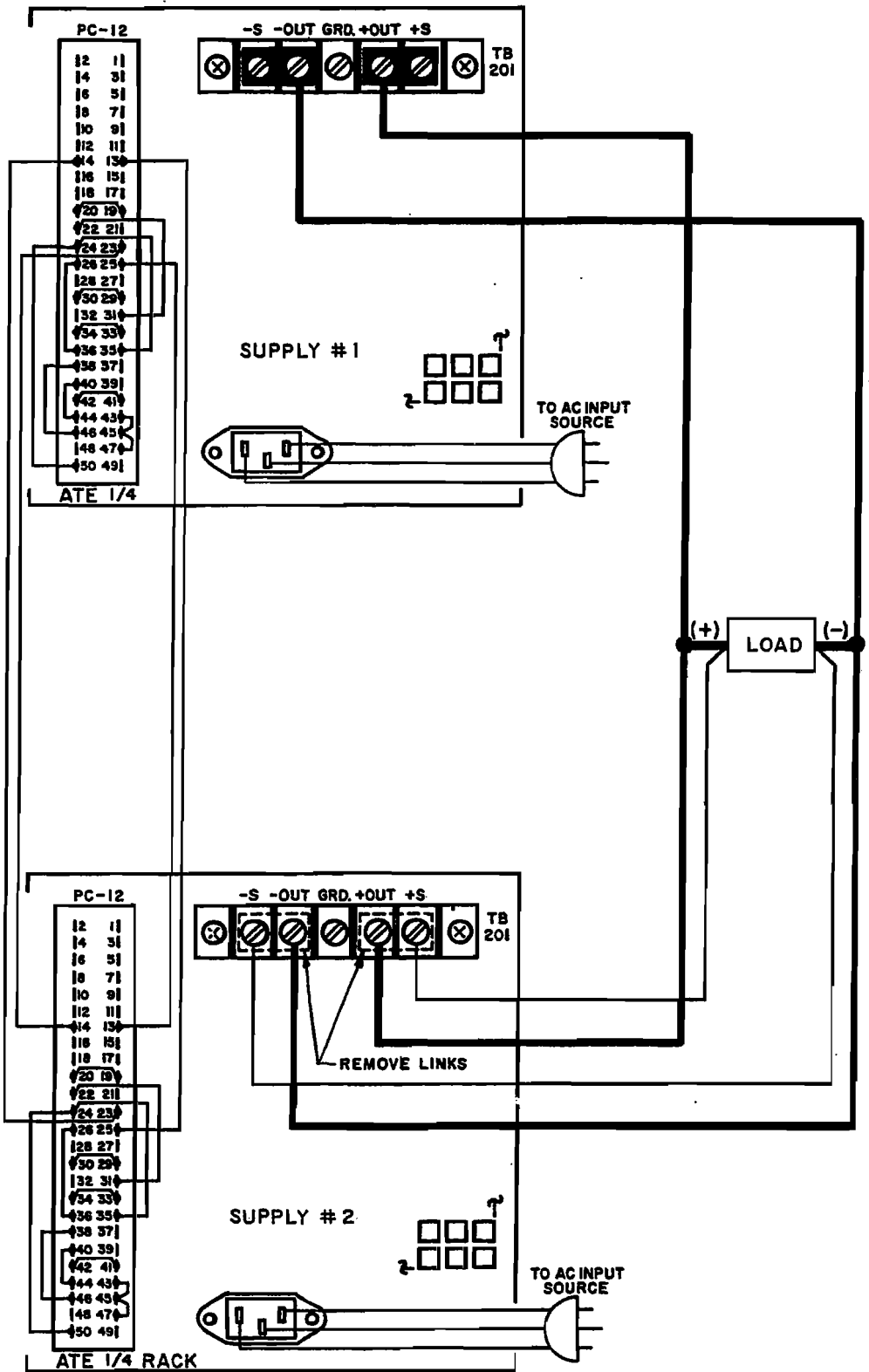

FIG. 3-25 CONNECTIONS FOR AUTOMATIC PARALLEL OPERATION.

3-108 MASTER/SLAVE PARALLEL CONNECTION

3-109 This method is especially convenient with ATE power supplies, since no external current sensing resistors are required and all control connections can be made via the ATE's rear PROGRAMMING CONNECTOR. In the MASTER/SLAVE parallel mode, the EXT. CURRENT COMPARISON AMPL on each SLAVE unit is disconnected from its 15V bias and is driven instead from the common MASTER CURRENT SENSING AMPL. As the MASTER supply delivers load current from zero to its rated maximum value, the signal from its CURRENT SENSING AMPL changes from zero to 1 volt. Applied to each SLAVE unit, this signal programs the output current of the SLAVE units from zero to the maximum value. While all Slave units will operate in the current mode, the MASTER unit can be operated in either the voltage or the current mode.

3-110 PROCEDURE, MASTER/SLAVE PARALLEL CONNECTION

- 1) All power supplies to be paralleled must be able to deliver the required compliance (load) voltage. Before paralleling, set each power supply voltage control to this voltage.
- 2) Make all load and sensing connections as shown in FIG. 3-26.
- 3) Turn all power supplies "on". Observe from panel meters and MODE indicator(s). Adjust the MASTER supply output controls for either voltage or current mode operation. All CURRENT MODE indicator(s) on the SLAVE supplies should be "on".

ON PC 12:
REMOVE JUMPER:
(23)-(25)

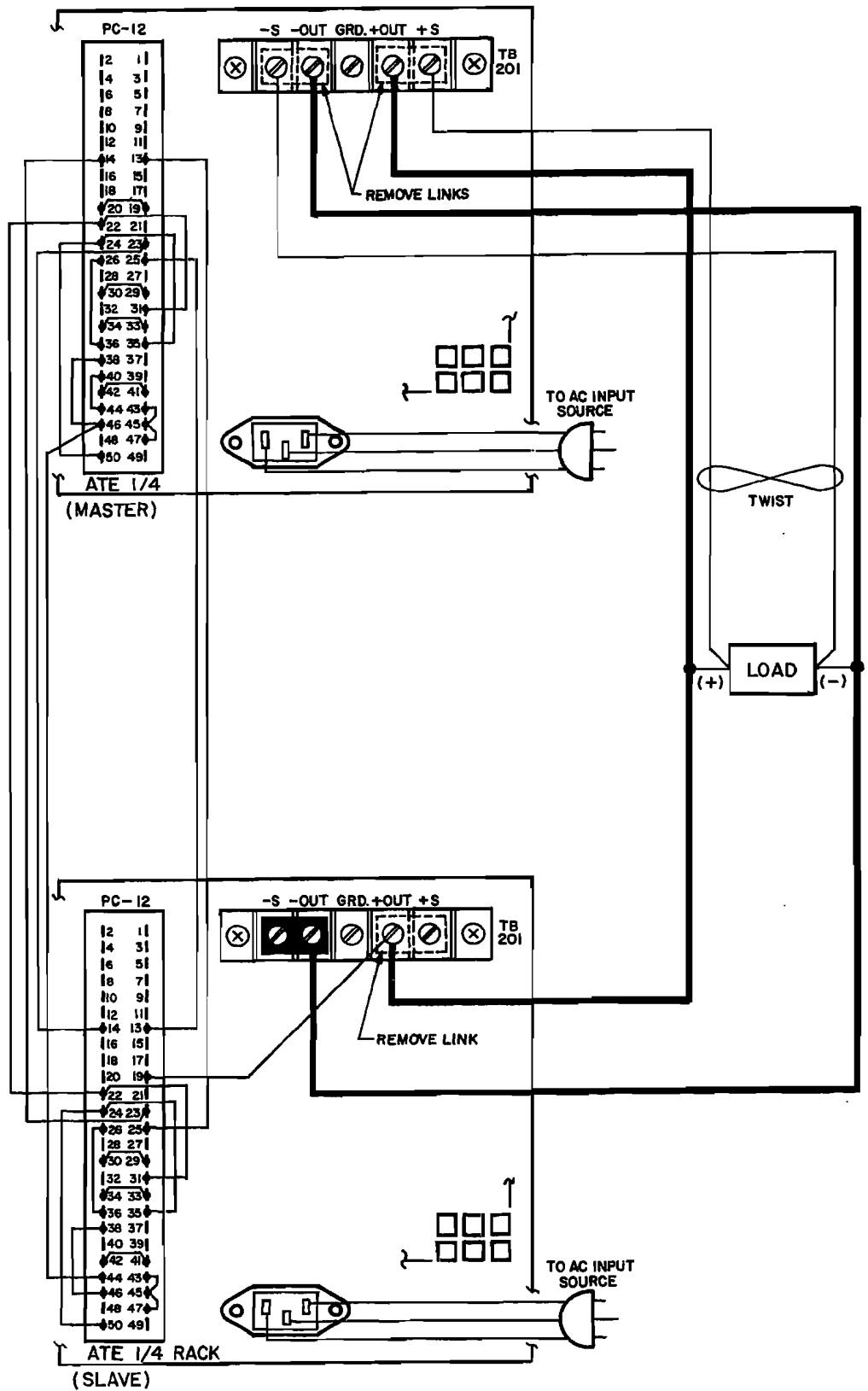

FIG. 3-26 MASTER/SLAVE PARALLEL CONNECTIONS

3-111 REDUNDANT PARALLEL OPERATION

3-112 Two ATE Power Supplies can be connected in parallel to a load in such a way that if one of the power supplies fails or is interrupted in any other manner, the other will continue to supply uninterrupted load current. The two power supplies are isolated from each other by means of external diodes (D1, D2 in FIG. 3-28) which must be rated for the maximum load voltage and current of the ATE units used.

3-113 The problem encountered in operating power supplies with overvoltage detection circuits in a redundant parallel configuration is that the overvoltage sensing leads are usually permanently wired to the error sensing leads. If now an overvoltage occurs on *either* power supply, *both* supplies will shut down, defeating the purpose of the redundant circuit. In the ATE power supplies, provisions are made on the control circuit P.C. card (A1), to disconnect the overvoltage sensing from the error sensing terminal, reconnect it to the output terminal and remove C26, thus successfully solving the problem described. (See FIG. 3-27).

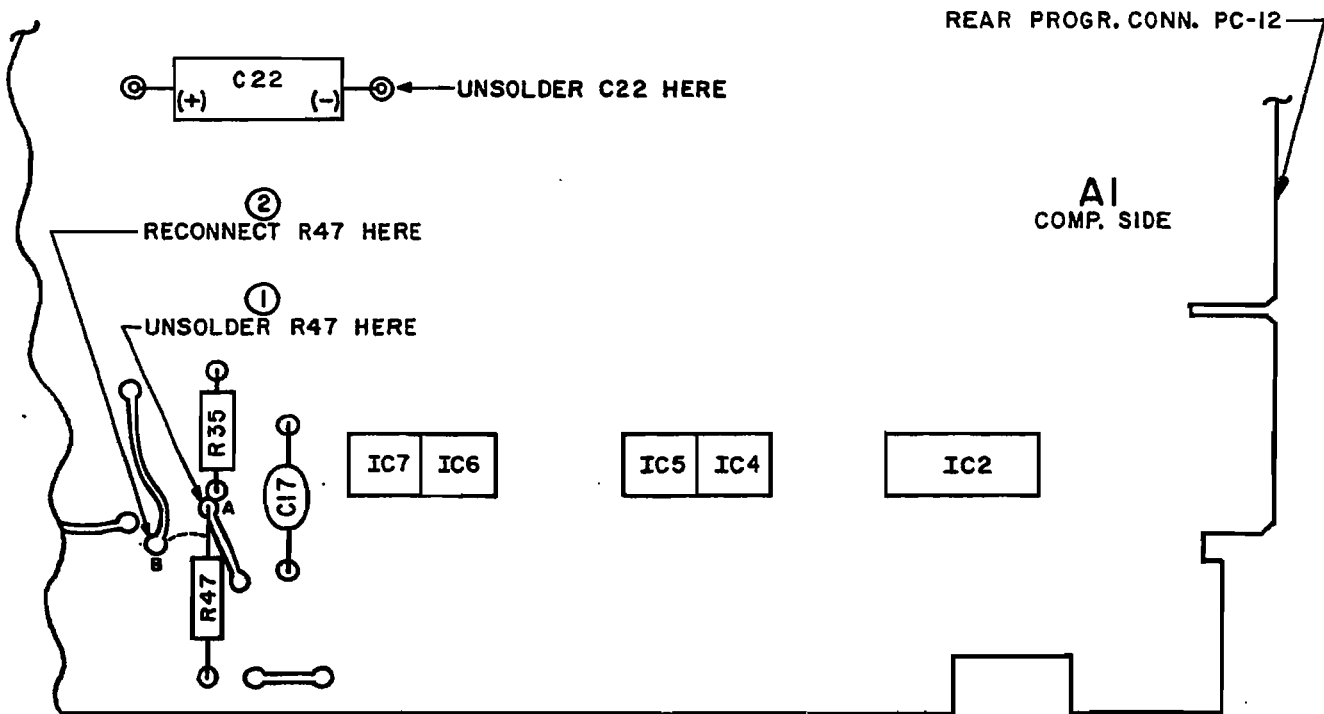

FIG. 3-27 LOCATION OF OVERVOLTAGE SENSING LEAD DISCONNECT.

3-114 PROCEDURE, REDUNDANT PARALLEL OPERATION

- 1) Remove covers from both ATE power supplies, locate A-1 P.C. card and rewire overvoltage sensing as described in par. 3-113 and as illustrated in FIG. 3-27. Remove capacitor C26 as described in par. 3-113 and as illustrated in FIG. 3-27.
- 2) Make all load and sensing connections as shown in FIG. 3-28.
- 3) Turn a-c power "on" and set both ATE supplies to the desired load voltage. One of the ATE supplies (Supply #1) will invariably be at a slightly higher output voltage than the other (Supply #2). Supply #1 will consequently be in control of the load, while Supply #2 will be cut-off. If Supply #2 is desired as the controller, increase its output voltage slightly, until it takes control of the load as evidenced by the read-out on its front panel meters. It is recommended the loading be at least 10% of the rated maximum ATE output current.
- 4) Test the redundant parallel system by manually shutting off the a-c power on the controlling power supply. The other supply should now deliver the power to the load.

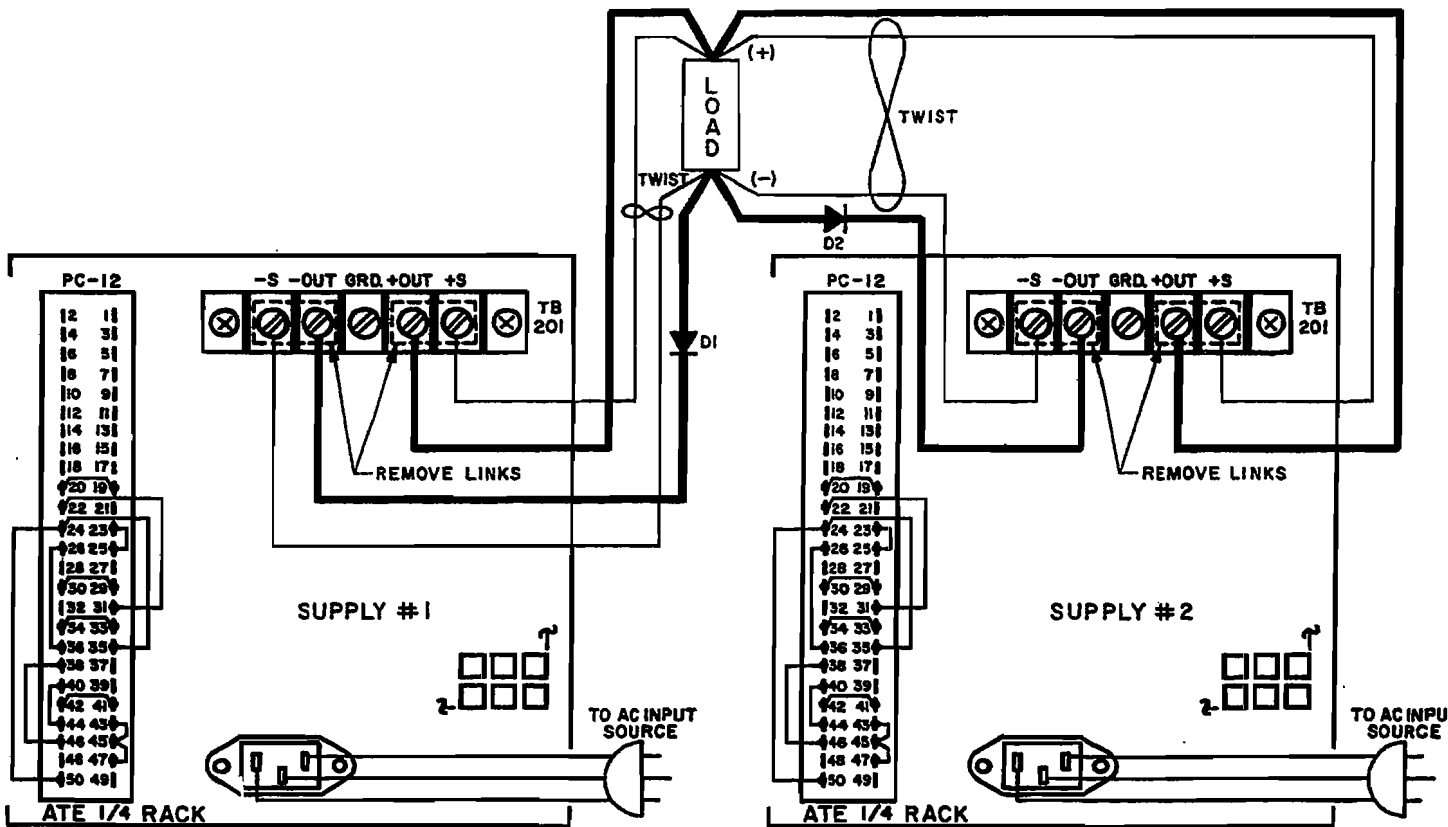

FIG. 3-28 REDUNDANT PARALLEL CONNECTION WITH ATE POWER SUPPLIES.

3-115 PROGRAMMING WITH REFERENCE TO THE NEGATIVE POWER SUPPLY OUTPUT

3-116 ATE power supplies may be used in many unique applications. The two uncommitted ATE preamplifiers make it possible to solve application problems which would require special circuitry or additional equipment with standard power supplies. One example of such an application problem is the case in which the programming common must be the *negative* output side of the power supply, rather than the positive side. With standard power supplies, either the programming source would have to be completely isolated, or an isolating interface would be required.

3-117 This problem is readily solved by the ATE power supply (See FIG. 3-29). PREAMP "A" is used to perform as a differential attenuator, permitting a level shift of the programming source, while PREAMP "B" brings the programming signal back to the required level (0–10V).

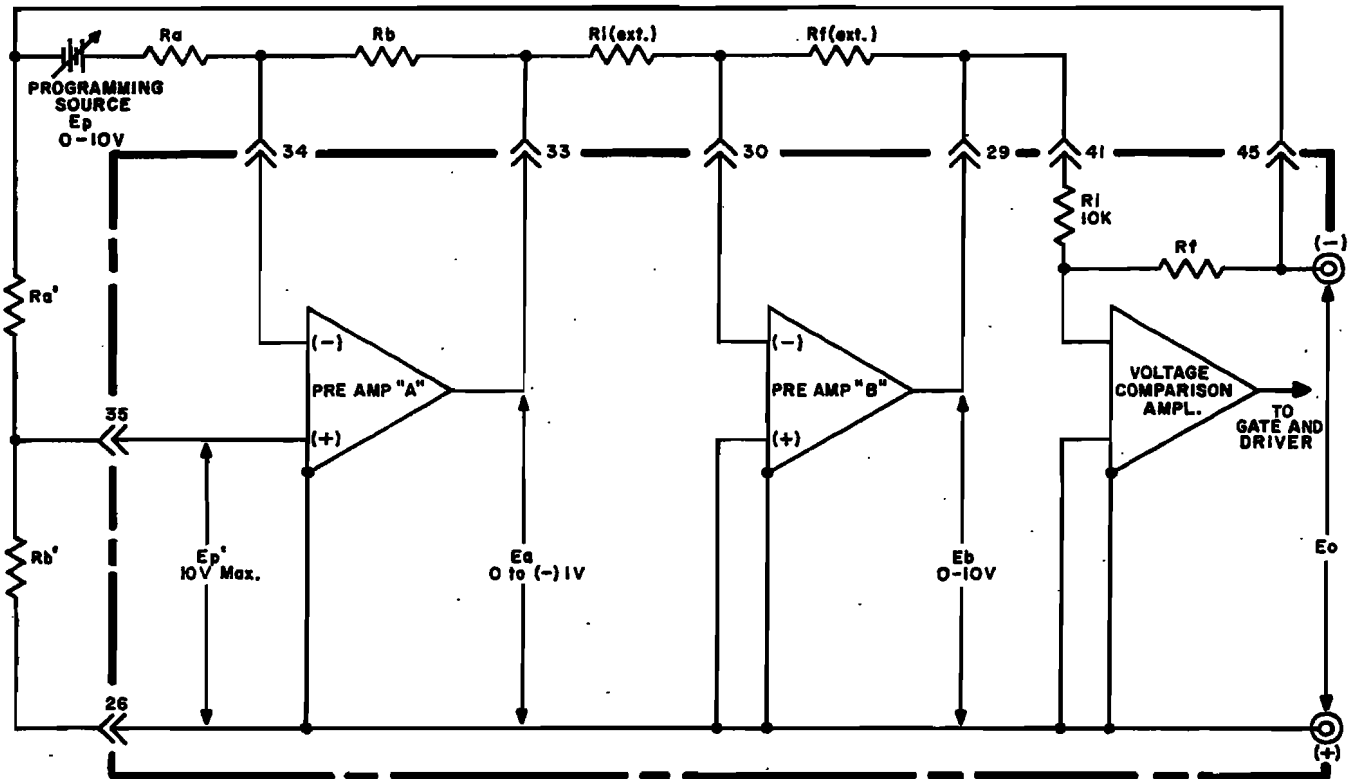

FIG. 3-29 PROGRAMMING WITH REFERENCE TO THE NEGATIVE OUTPUT SIDE OF THE ATE.

Definition of Symbols in FIG. 3-29:

E_o = Power Supply Output Voltage

E_a = PREAMP "A" Output Voltage

E_b = PREAMP "B" Output Voltage

E_p' = Common Mode Voltage Limit (10 Volts max.)

E_p = Programming Voltage

$R_a = R_a'$
 $R_b = R_b'$ Voltage Divider Network

3-118 Component selection will depend on the parameters of the programming source and the ATE power supply output voltage. AN EXAMPLE: An ATE model with an output voltage of 0–100 Volt is programmed through its full output voltage range by a programming source (E_p) of 0–10 volt which can supply 0.1mA. The negative output side of the ATE is grounded. Selecting the voltage divider (R_a', R_b'), such that the common mode voltage, $E_p' < 10V$, we let $R_a = R_a' = 1M$ ohm, $R_b = R_b' = 100K$ ohm. In this case the output voltage for PREAMP "A" can be expressed by:

$$(-) E_a = E_p R_b/R_a = 0 \text{ to } (-) 1 \text{ volt}$$

Note: The equation for the standard differential amplifier is derived in Burr-Brown's "Operational Amplifiers".

3-119 The next step is to select the input resistor (R_i ext.) and the feedback resistor (R_f ext.) for PREAMP "B". Since an input voltage (E_b) of 0 to 10 volts is required to drive the VOLTAGE COMPARISON AMPL (and thereby the power supply output voltage) over its rated range, the previously derived signal from PREAMP "A" must be reversed and amplified with a gain of 10. PREAMP "B" is used in the inverting configuration, for which the output equation is:

$$E_b = (-) E_a R_f (\text{ext.})/R_i (\text{ext.})$$

Selecting a 1K ohm resistor for R_i (ext.), R_f (ext.) must be 10K ohm to achieve the desired result.

Note: The selected resistors should be high quality components with a tolerance of 1%. They should be be wired as close to the PROGRAMMING CONNECTOR terminals as possible.

3-120 PROCEDURE, PROGRAMMING WITH REFERENCE TO THE NEGATIVE POWER SUPPLY OUTPUT

- 1) Connect the external components, the LOAD and the PRECISION VOLTMETER (M1) to the ATE as shown in FIG. 3-30.
- 2) With the EXT. CONTROL SOURCE at zero, turn ATE "on".
- 3) Vary the EXT. CONTROL SOURCE from zero to 10 volts. The ATE output voltage, as read out on M1, should vary approximately from zero voltage to the rated value. Return the EXT. CONTROL SOURCE to zero.

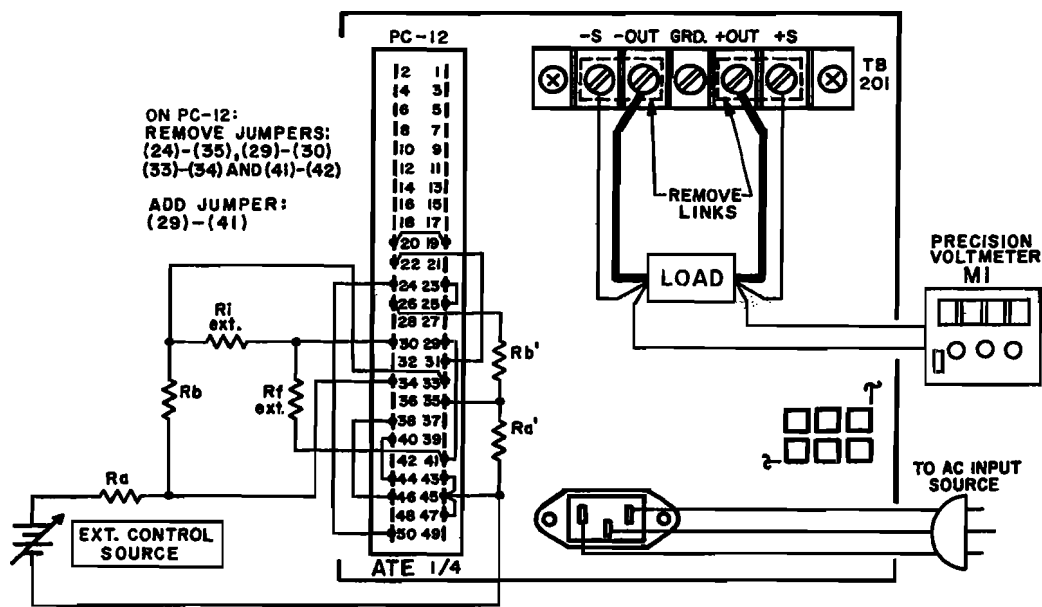

FIG. 3-30 CONNECTIONS FOR PROGRAMMING WITH REFERENCE TO THE NEGATIVE POWER SUPPLY OUTPUT.

3-121 APPLICATION OF THE ISOLATED FLAG SIGNALS

3-122 Two opto-isolated flag signals are provided at the rear programming connector (PC-12). One of them signals the ATE operating mode (Voltage or Current Mode), the other one provides a signal to indicate that the ATE crowbar has been tripped. Both flag signals consist of the Collector/Emitter terminals of a Photo-Transistor Optical Isolator and change their impedance from high to low if activated. The ATE flag signals may be converted to TTL logic signals as indicated in FIG. 3-31. The photo transistors are capable of sinking at least one (1) standard TTL load (1.6mA). Since the crowbar flag signal is followed by the shut-down of the ATE power supply, the flag signal is the form of a pulse, rather than a permanent level shift.

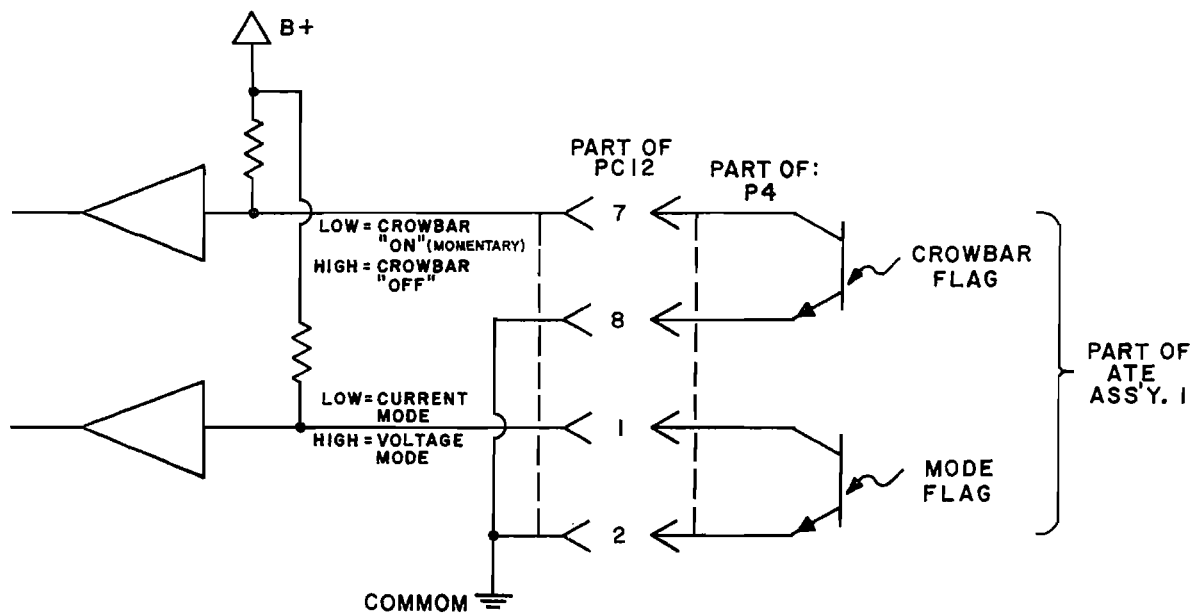

FIG. 3-31 ISOLATED FLAG SIGNAL OUTPUTS.

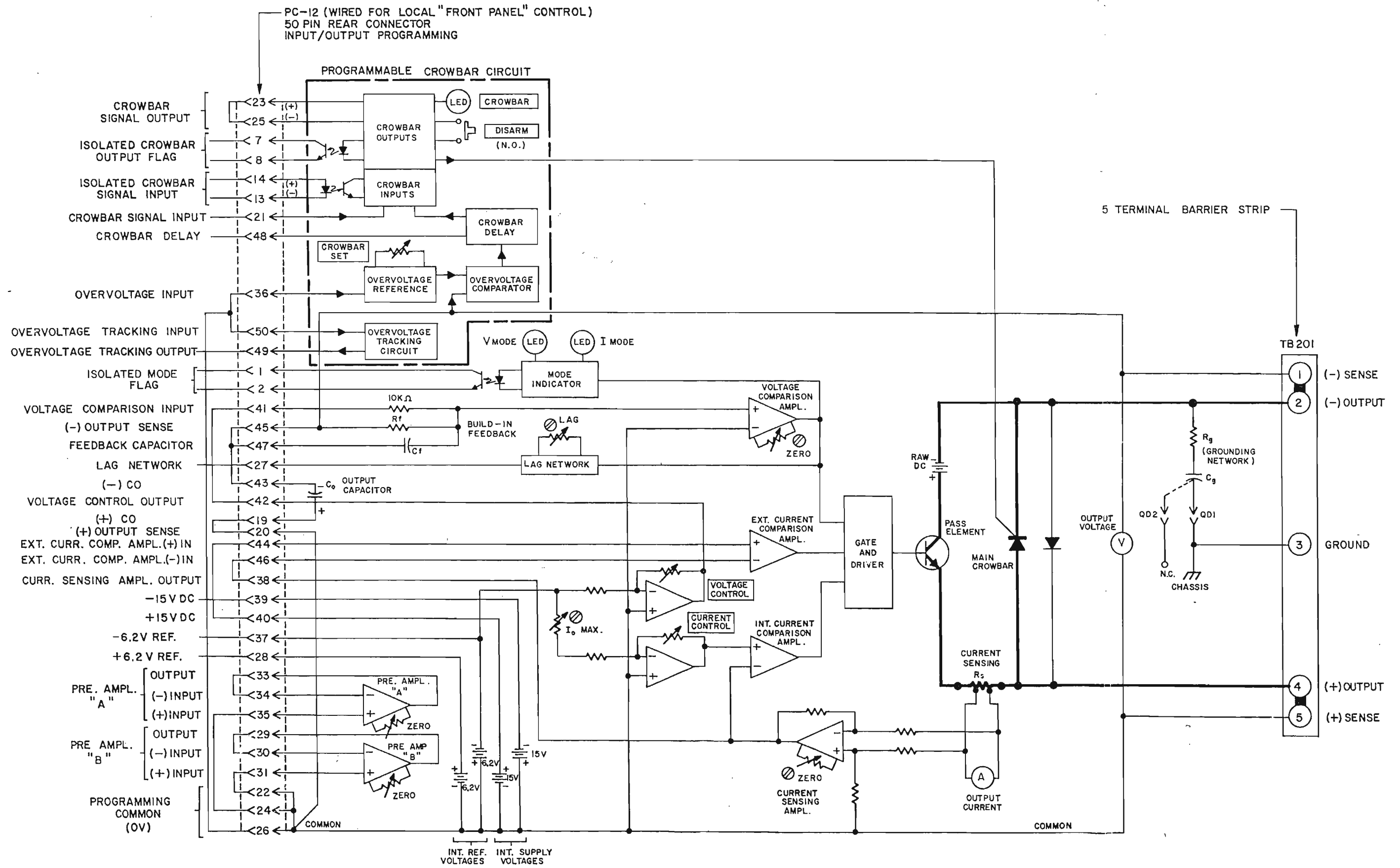
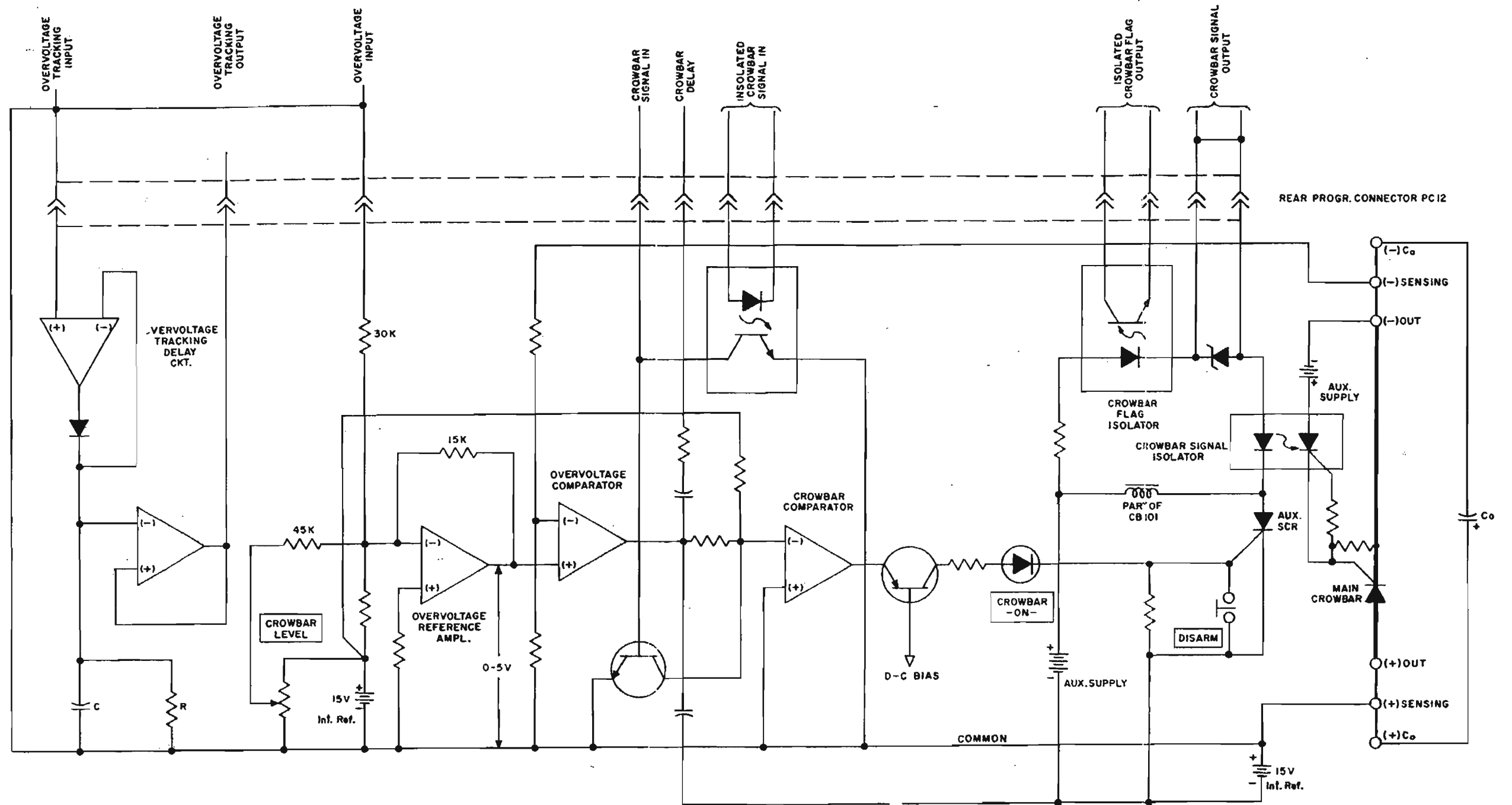

FIG. 3-32 ATE 1/4 RACK SIMPLIFIED SCHEMATIC DIAGRAM



NOTES: 1. NOMENCLATURE SAME AS IN MAIN SCHEMATIC DIAGRAM.
 2. JUMPER CONNECTIONS ON PC 12 ARE FOR FRONT PANEL (LOCAL) OUTPUT CONTROL.

FIG. 3-33 PROGRAMMABLE OVERVOLTAGE PROTECTOR AND CROWBAR CIRCUIT, SIMPLIFIED SCHEMATIC DIAGRAM

