

INSTRUCTION MANUAL



KEPCO An ISO 9001 Company.

CA 44-R
COVER

ENCLOSURES AND HARDWARE SYSTEMS

DESCRIPTION. The Kepco Model CA 44-R RoHS-compliant Cover (see Figure 1) is supplied for use with Kepco Series RTW 150 Watt power supplies. Installing this cover changes the model suffix from K to KC. The cover includes three M3 X 6mm screws (Kepco P/N 101-0433) used to attach the cover to the power supply as shown in Figure 1. These screws must not be overtightened (max. torque 10 in.- lbs (1.1 N x m).

NOTE: RTW 150W power supplies with this cover installed do not have agency approvals.

REMOVE EXISTING SCREW (M3 x 8) FROM
RTW POWER SUPPLY AND USE TO SECURE
COVER TO POWER SUPPLY.
MAX TORQUE 10 1N.-LBS (1.1N x m)

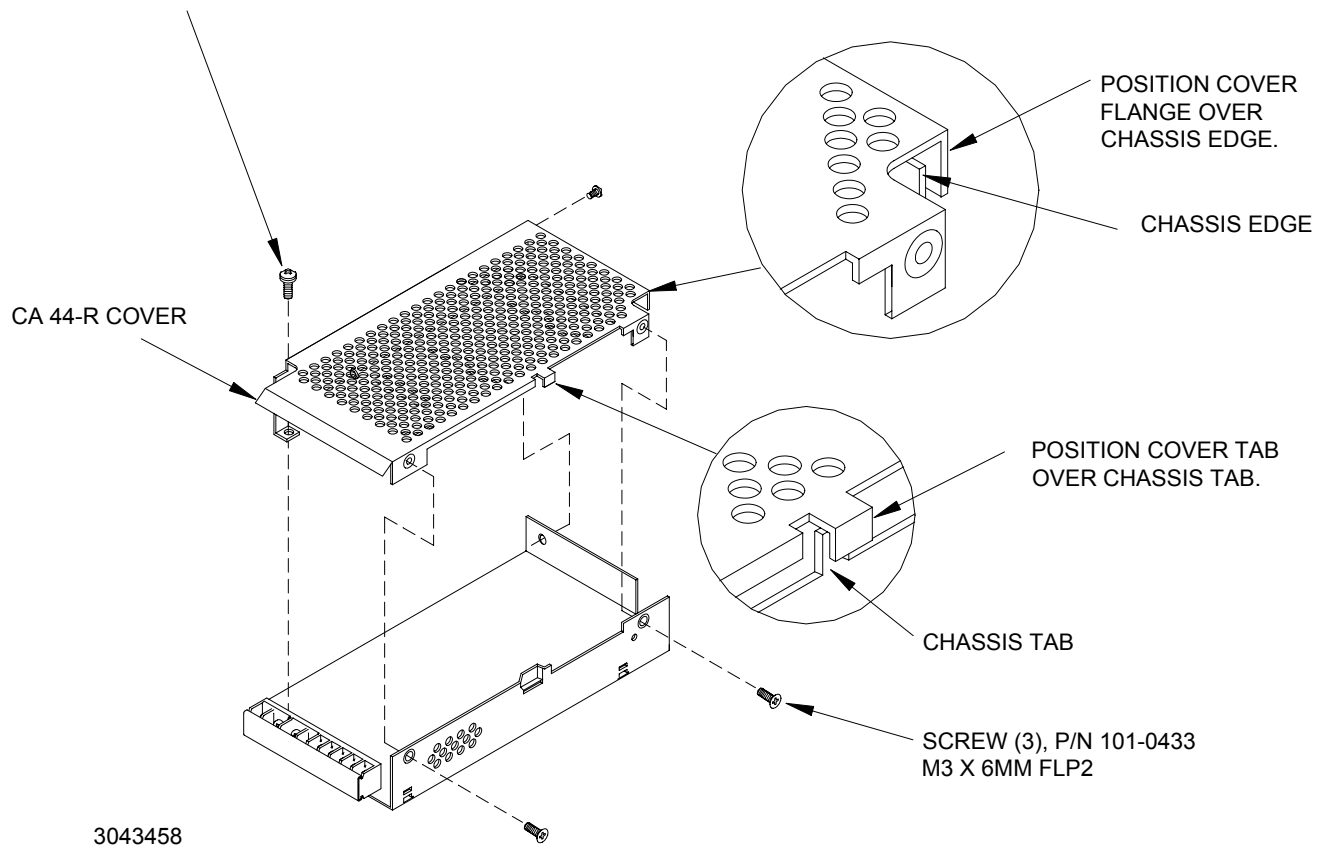

FIGURE 1. CA 44-R COVER INSTALLATION

KEPCO, INC. ● 131-38 SANFORD AVENUE ● FLUSHING, NY. 11355 U.S.A. ● TEL (718) 461-7000 ● FAX (718) 767-1102
<http://www.kepcopower.com> ● email: hq@kepcopower.com