

INSTRUCTION SHEET

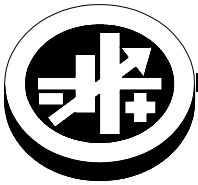

KEPCO An ISO 9001 Company.

**MA
FAW/RTW
150V**

MOUNTING ADAPTER FAW/RTW 150V

DESCRIPTION. The RoHS-compliant Model MA FAW/RTW 150V Mounting Adapter includes an adapter plate and mounting screws that allow a 150W RTW power supply to be easily substituted for a vertically-mounted 150W FAW power supply. Mount the adapter plate to the RTW power supply using the screws provided (see Figure 1), then install the adapter plate in place of the FAW power supply using the screws that previously secured the FAW power supply.

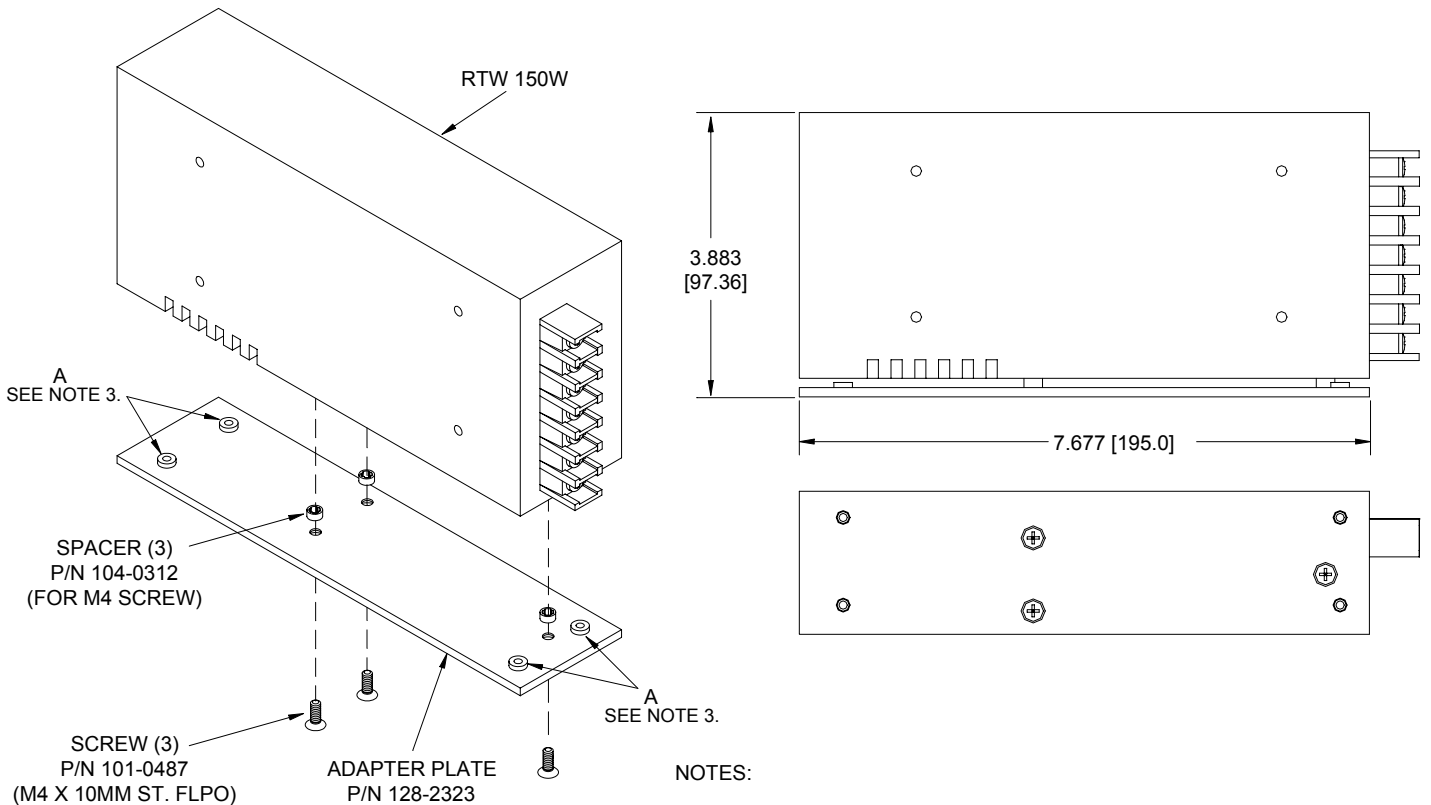

NOTES:

1. MOUNT ADAPTER PLATE TO RTW USING THREE SCREWS AND THREE SPACERS AS SHOWN.
2. INSTALL ADAPTER PLATE WITH RTW ATTACHED USING "A" HOLES AND FOUR SCREWS PREVIOUSLY USED TO MOUNT FAW POWER SUPPLY (NOT SUPPLIED).
3. MAX. PENETRATION AT "A" (SCREW 4-40) MUST NOT EXCEED 5MM.

3043306

FIGURE 1. ADAPTER PLATE INSTALLATION

KEPCO, INC. ● 131-38 SANFORD AVENUE ● FLUSHING, NY. 11355 U.S.A. ● TEL (718) 461-7000 ● FAX (718) 767-1102
<http://www.kepcopower.com> ● email: hq@kepcopower.com