

OPERATOR'S MANUAL

RKW 1500W SERIES

POWER SUPPLY

SINGLE OUTPUT, UNIVERSAL INPUT
SINGLE PHASE, 0.99 POWER FACTOR

KEPCO INC.
An ISO 9001 Company.

MODEL

RKW 1500W SERIES

POWER SUPPLY MODELS

**RKW 3.3-375K, RKW 5-300K, RKW 12-125K,
RKW 15-100K, RKW 24-65K, RKW 28-55K,
RKW 48-32K**

IMPORTANT NOTES:

- 1) The contents of this manual are protected by copyright. Reproduction of any part can be made only with the specific written permission of Kepco, Inc.
- 2) Data subject to change without notice.

©2010, KEPCO, INC
P/N 228-1503-REV 5



KEPCO, INC. • 131-38 SANFORD AVENUE • FLUSHING, NY. 11355 U.S.A. • TEL (718) 461-7000 • FAX (718) 767-1102
email: hq@kepcopower.com • World Wide Web: <http://www.kepcopower.com>

TABLE OF CONTENTS

SECTION	PAGE
1. Introduction.....	1
1.1 Scope of Manual.....	1
1.2 Description.....	1
2. Specifications	1
3. Optical Coupler Output Alarm Circuit	5
4. Operation.....	6
4.1 Voltage Adjustment	7
4.2 Remote Voltage Control	8
4.3 Remote Turn On-Turn Off.....	8
5. Alarm Functions.....	8
5.1 Overvoltage And Overtemperature Protection.....	8
5.2 Overcurrent Protection	9
5.3 Fan Failure	9
5.4 Undervoltage	9
6. Load Connection	9
6.1 Connecting The Load Using Local Sensing.....	9
6.2 Connecting The Load Using Remote Sensing.....	9
6.3 Parallel Connection	10
6.4 Series Connection	12
6.5 Preliminary Electrical Check	12
7. Fan Maintenance.....	13

LIST OF FIGURES

FIGURE	TITLE	PAGE
1	Mechanical Outline Drawing Of The RKW 1500W Power Supply.....	4
2	Output Alarm Circuit Optically Isolated.....	5
3	RKW 1500W Power Failure Timing Diagram	5
4	Power Rating Vs. Temperature	6
5	Mounting Positions For The RKW 1500W Power Supply	6
6	Locations Of Operating Controls, Indicators and Terminals.....	7
7	Connections For Remote Voltage Control.....	8
8	Correct and incorrect Methods of Load Connection.....	10
9	Parallel Connection with Current Balancing	10
10	Parallel Connection, Master-Slave, Multiple Loads.....	11
11	Parallel Connection, Master-Slave, Single Load	11
12	Series Connection	12
13	Functional Checkout.....	13

LIST OF TABLES

TABLE	TITLE	PAGE
1	Output Ratings and Specifications	1
2	Power Supply Ratings and Specifications	2

1. INTRODUCTION

1.1 SCOPE OF MANUAL

This Operator's Manual covers the installation and operation of the Kepco RKW 1500W Series of PFC (Power Factor Corrected), RoHS (Reduction of Hazardous Substances) compliant, switching power supplies. For service information, write directly to: Kepco Inc., 131-38 Sanford Avenue, Flushing, New York, 11355, U.S.A. Please state Model Designation and Serial Number of your RKW Power Supply. This information can be found on the nameplate of the unit.

1.2 DESCRIPTION

The Kepco RKW 1500W Series consists of seven models of switching power supplies, each with a single output as shown in Table 1. Units may be operated with a nominal 100V a-c to 240V a-c (input voltage range 85 to 265 Va-c), 50-60 Hz (input frequency range 47-66Hz). They will also operate on 110V to 370V d-c input. The RKW 1500W Series employs a light weight ferrite core with a switching frequency of about 140 KHz (about 100 KHz for the 3.3 volt model). Regulation is provided by pulse width modulation. A power stage with two MOSFETS on each side of the primary winding, operating in the forward mode provides a smooth isolated d-c output. A thyristor circuit prevents excessive turn-on current surge. Overvoltage, overcurrent, undervoltage, overtemperature and fan failure protections, an isolated remote TTL ON-OFF control, a power fail signal and current balancing (for parallel operation) are provided. An LED "output voltage ON" light and an output voltage adjust trimmer are visible near the output bus bars (right side of the case). Units are manufactured on a steel frame with a steel cover.

2. SPECIFICATIONS

Table 1 contains specifications and operating limits of individual RKW 1500W Series models. Table 2 contains specifications and operating limits common to all RKW 1500W Series Models. These specifications are at nominal input voltages at 25°C unless otherwise specified.

TABLE 1. OUTPUT RATINGS AND SPECIFICATIONS

MODEL RKW 1500W		3.3-375K	5-300K	12-125K	15-100K	24-65K	28-55K	48-32K	
Output Volts d-c		3.3V	5V	12V	15V	24V	28V	48V	
Adjustment Range		1.8-3.6	3.5-6.0	7.2-14.4	10.5-18.0	16.8-28.8	19.6-33.6	33.6-52.8	
Voltage Setting		3.3 ±0.03	5 ±0.05	12 ±0.12	15 ±0.15	24 ±0.24	28 ±0.28	48 ±0.48	
Maximum Output Ratings (A,W)	-10°C to 40°C	Amps	375	300	125	100	65	55	32
		Watts	1237.5	1500	1500	1500	1560	1540	1536
	50°C amb	Amps	346.88	300	125	100	65	55	32
		Watts	1144.69	1500	1500	1500	1560	1540	1536
	60°C, amb	Amps	300	240	100	80	52	44	25.6
		Watts	990	1200	1200	1200	1248	1232	1228.8
65°C, amb	Amps	262.5	210	87.5	70	45.5	38.5	22.4	
	Watts	866.25	1050	1050	1050	1092	1078	1075.2	
Overcurrent Setting (Amps) ⁽¹⁾		390-430	315-350	130-140	105-115	68-72	57.7-63.2	33.6-36.8	
Current Short Circuit		430	350	152	135	80	70	45	
OVP Setting (Volts) ⁽²⁾		4.0 - 4.6	6.2 - 7.0	14.8 - 16.8	18.6 - 21.0	29.8 - 33.6	34.7 - 39.2	55.0 - 59.9	
Efficiency % typical	AC Input 100V	73	77	80	82	82	82	84	
	AC Input 200V	77	82	84	86	86	86	88	
Ripple & Noise ⁽³⁾ (mV, p-p)	ripple	100	100	150	150	200	200	300	
	ripple noise	200	200	200	200	300	300	400	

- (1) Square type. If overcurrent condition continues for approximately 30 seconds, the output is shut OFF. Recovery is by removing power and reapplying power after about 40 seconds or by opening and reclosing the RC terminals .
- (2) When overvoltage is detected, output is shut OFF. Recovery is by removing power and reapplying power after about 40 seconds or by opening and reclosing the RC terminals (no delay).
- (3) Ripple and noise specifications is 1.5 times the indicated values for a temperature range of -10 to 0°C. Ripple and noise levels above are satisfied when conditions are 0 to 100% load, 0 to 65°C, and bandwidth <= 100MHz.

TABLE 2. POWER SUPPLY RATINGS AND SPECIFICATIONS

SPECIFICATION	DESCRIPTION		
Input Voltage	85-265V a-c	(0 to 100% load, -10 to 65°C)	
	110-370V d-c	Polarity insensitive (0 to 100% load, -10 to 65°C) Safety agency approval applies only to a-c input operation.	
Input Source Frequency	50-to 60 Hz	47-440 Hz. (At 440 Hz the leakage current exceeds the UL leakage safety specification limit).	
Input Current: (Maximum Load At 25°C with Nominal Output Voltage)	22A rms max. (18A rms max for the 3.3V model)	100 - 120V a-c	
	11A rms max. (9A rms max for the 3.3V model)	200 - 240V a-c	
Input Protection	A limiting resistor in series with a resistor fuse (in parallel with a thyristor circuit) reduces start-up surge. Units are protected against shorts by an input fuse. Fuse value 30.0A At 250 Volts		
Input Surge cold start, interval > 30 sec ⁽¹⁾	15A typ., 20A max. first surge	100 - 120V ac	
	30A typ., 40 max. first surge	200- 240 V ac	
Leakage Current:	0.5mA typ., 0.8mA max. at 120V a-c, 60Hz (per IEC 950 and UL1950) 1.1mA typ., 1.6mA max. at 240V a-c, 60Hz (per IEC 950 and UL1950)		
Power Factor	0.99 typical	100 - 120V a-c, rated output	
	0.95 typical	200 - 240V a-c, rated output	
Stabilization	Source Effect (min - max) (85 to 132 V a-c, 170 to 265V a-c)	Typical	Maximum
		0.1% (0.15% for 3.3V Model)	0.2% (0.3% for 3.3V Model)
	Load Effect, measured at sensing terminals (0%-100% load change)	0.3% (0.45% for 3.3V Model)	0.6% (0.9% for 3.3V Model)
		Temperature Effect (-10° to 65°C)	0.5%
	Combined Effect (envelope, Source, Load and Temperature)	±0.9% (±1.1% for 3.3V Model)	±1.8% (±2.2% for 3.3V Model)
	Drift (8 hours at 25°C)	0.2%	0.5%
Remote Error Sensing:	Compensation up to 0.4 Volts per load wire (0.15 Volts for RKW 3-375, 0.25 Volts for RKW 5-300K) (see Figure 8).		
Transient Recovery characteristic	excursion	±4% maximum	50% to 100% load, transient time >50µsec
	recovery time	1 ms maximum	
Start-up Time	500 msec maximum, 280 msec typical.	100V a-c	
	400 msec maximum, 180 msec typical.	240V a-c	
Output Hold-up Time	35 msec typical, 20 msec minimum.	100V a-c	
	40 msec typical, 20 msec minimum.	240V a-c	
Thermal Protection	When the Power Supply goes into thermal protection, the output is cut OFF. To restart (reset) the unit after it has cooled, it is necessary to remove the a-c input power, wait about 40 seconds, and then to reconnect the a-c input power or to open and then reclose the RC terminals.		

(1) First surge only, not including current flow into EMI filter

TABLE 2. POWER SUPPLY RATINGS AND SPECIFICATIONS (CONTINUED)

SPECIFICATION	DESCRIPTION	
Remote Control ON/OFF:	"High", 2.4V to 24V (or open), unit OFF- Fan Off ; "Low", 0.0V to 0.4V (or closed), unit ON. Source current is 1.6mA maximum at low level, and sink current is 1.0 mA maximum at high level. The ±RC terminals are isolated from the a-c input terminal and the DC output terminals. When remote ON/OFF is not in use, ±RC terminals must be shorted (use shorting link supplied) for unit to operate.	
Operating Temperature:	-10 to 65°C (see Figure 4)	
Startup Temperature	-20 to -10°C (see Figure 4)	
Storage Temperature:	-30°C to +75°C	
Withstanding voltage : (at 15-35°C ambient, 10-85% relative humidity)	2000Va-c for 1 minute. Cutout current is 20mA	Between input and ground
	500Va-c for 1 minute. Cutout current is 300mA	Between output and ground
	3000Va-c for 1 minute. Cutout current is 20mA	Between input and output terminal
Insulation Resistance: (at 15-35°C ambient, 10-85% relative humidity)	Between output and ground, input and ground, and input and output, 100 Megohms minimum (500Vdc)	
Humidity:	10% to 95% relative humidity, noncondensing, Wet Bulb temperature ≤ 35°C	operating and non-operating
Vibration:	5-10 Hz., 10mm amplitude, 10-200 Hz., acceleration 64.3ft./s ² (19.6m/s ²) (2g)	non-operating 1 hr. on each of 3 axes, sweep time 10 minutes
Shock: (non-operating, 1/2 sine pulse, three shocks on each axis, Power Supply is fixed on its bottom side)	Acceleration: 964.6ft./s ² (294m/s ²) (30g), Pulse Duration: 11ms ± 5 msec	
Safety:	All units designed to meet UL1950, CSA Electrical Bulletin 22.2 No.950-95 (certified by UL), and TÜV Rheinland EN60950 (ambient temp. 50°C max., 3.3V Model: 40°C max.). RKW 1500W units are CE marked per the Low Voltage Directive (LVD), 73/23/EEC and 93/68/EEC. [The standards do not apply with DC input operation.]	
EMI Conducted:	Designed to meet FCC Class A, VCCI-Class A, EN55011-A, EN55022-A. With filter P/N 245-0031: FCC Class B, VCCI-Class B, EN55011-B, EN55022-B	
EMI Radiated:	Designed to meet FCC Class A, VCCI-Class A, EN55011-A, EN55022-A With filter P/N 245-0031: FCC Class B, VCCI-Class B, EN55011-B, EN55022-B	
Input current harmonics:	Designed to meet EN61000-3-2.	
Immunity:	Designed to meet EN50082-2.	
ESD immunity:	EN61000-4-2, level 4	normal operation
Fast transient burst immunity:	EN61000-4-4 level 3	normal operation
Surge immunity:	EN61000-4-5, level 4	no damage
Power Frequency Magnetic Field immunity:	EN61000-4-8, level 4	normal operation
Radiated field immunity:	EN61000-4-3 level 3	normal operation
Conducted noise immunity:	EN61000-4-6 level 3	normal operation
Voltage dips interruptions and variations	EN61000-4-11	normal operation
Dimensions:	3.62 in. (92 mm) x 7.48 in. (190 mm) x 11.81 in. (300 mm)	
Mounting:	Four No. M4 tapped holes on the sides and the bottom	
Maximum Screw Penetration:	0.24 in. (6 mm)	
Cooling:	Forced air flow - two fans	
Frame Material/Cover Material:	Steel	
Weight	13.2 lbs, 6.0Kgs. maximum	

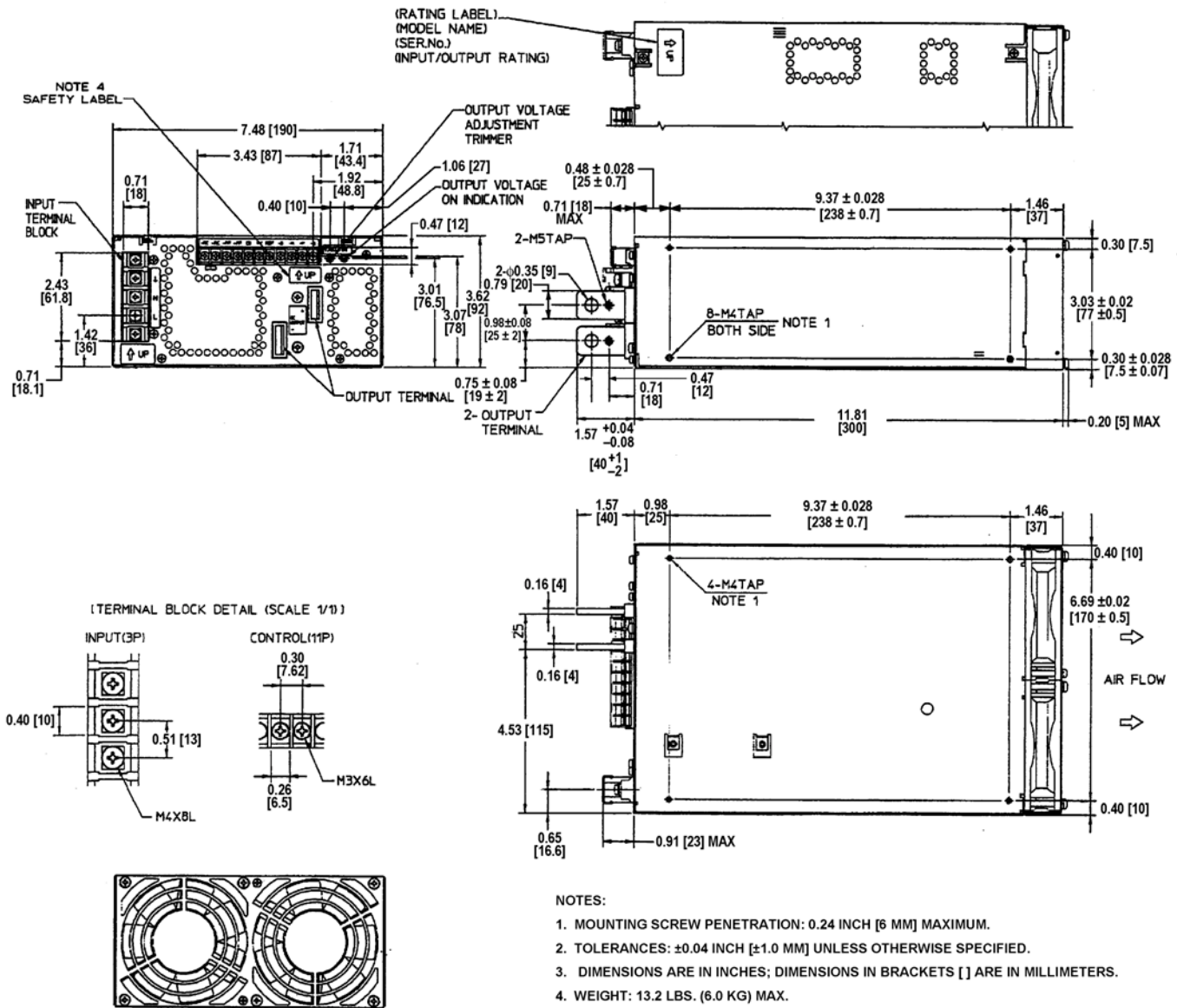

3010238

FIGURE 1. MECHANICAL OUTLINE DRAWING OF THE RKW 1500W POWER SUPPLY

3. OPTICAL COUPLER OUTPUT ALARM CIRCUIT

When the output voltage falls to less than about 80 percent of programmed output voltage the alarm is activated (a high logic level will appear at the \pm PF terminals). The default state of the alarm is logic low. The sink current is 50mA maximum, the maximum collector to emitter saturation voltage is 0.40 Volts, and the collector to emitter voltage is 40 volts maximum. The PF terminals are isolated from the AC and DC output input terminals. Insulation resistance between the PF terminals and the AC input terminals is the same as the insulation resistance between the input and output. Insulation resistance between the PF terminals and the output terminals is the same as the insulation resistance between the output and ground.

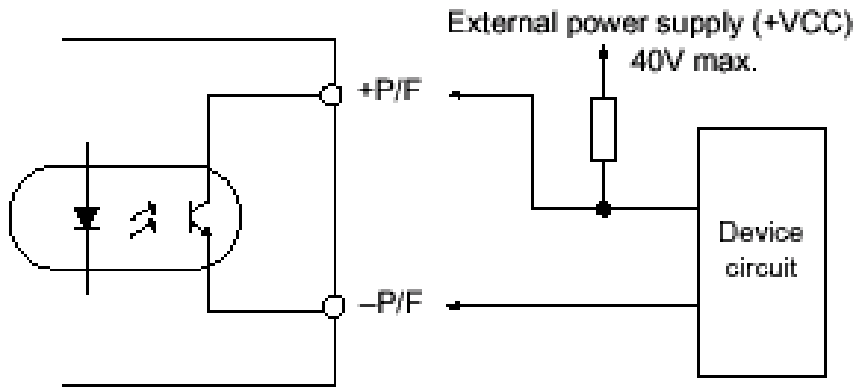

FIGURE 2. OUTPUT ALARM CIRCUIT OPTICALLY ISOLATED

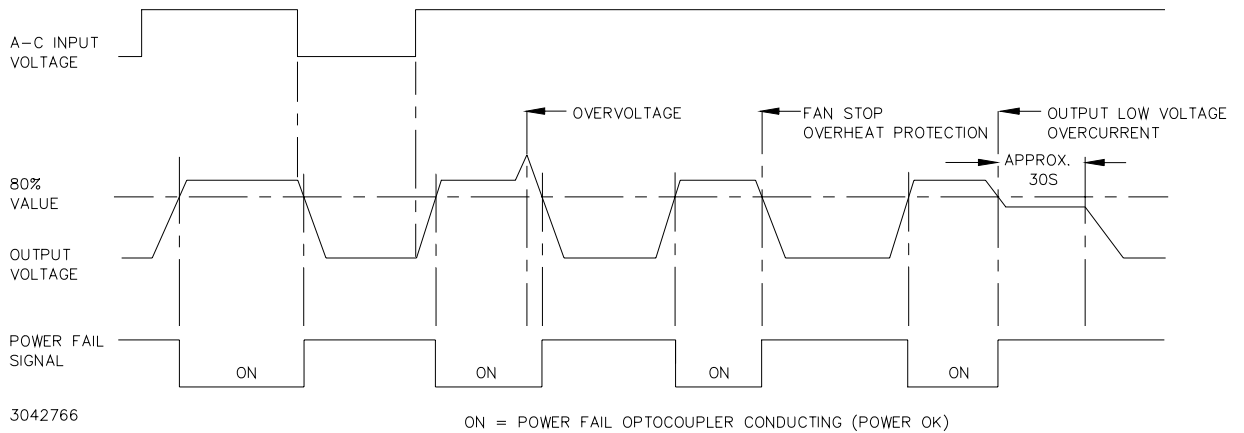

FIGURE 3. RKW 1500W POWER FAILURE TIMING DIAGRAM

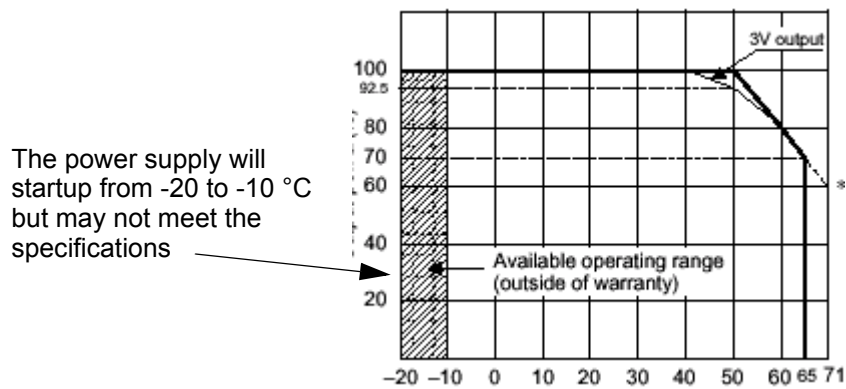

FIGURE 4. POWER RATING VS. TEMPERATURE

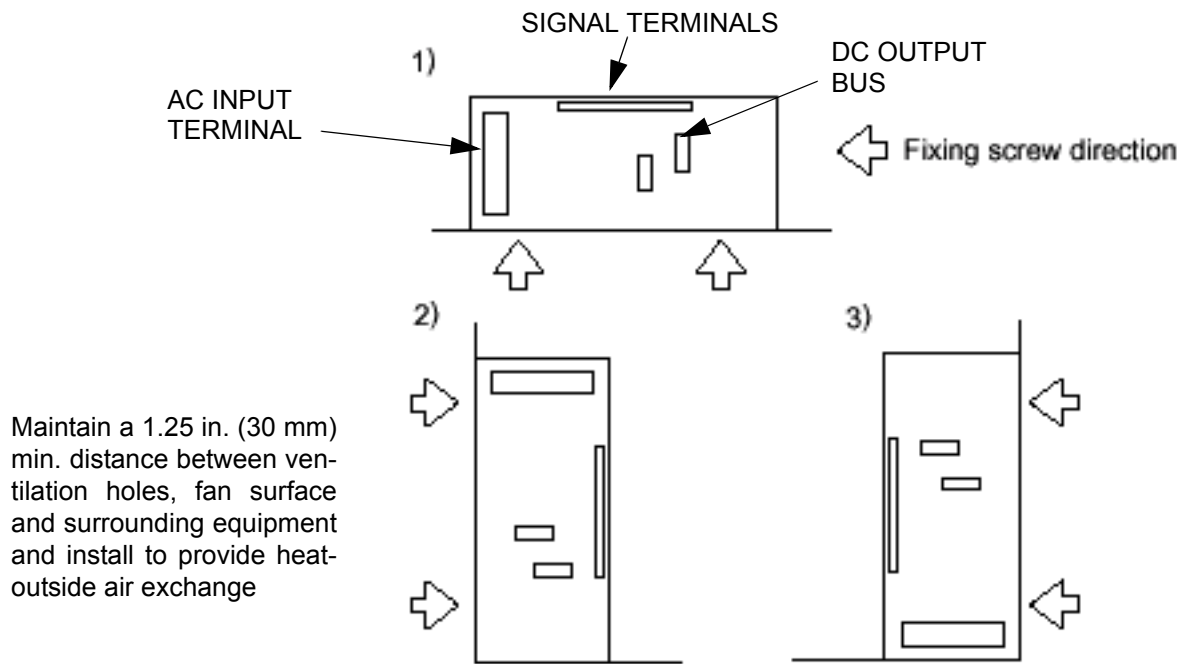

FIGURE 5. MOUNTING POSITIONS FOR THE RKW 1500W POWER SUPPLY

4. OPERATION

Figure 6 shows the location of all operating controls and input/output terminals; Table 3 provides an explanation of each. The unit is shipped with shorting links installed connecting the following terminals: +RC to -RC and REF to RV, +M with +S and -M with -S (+M, -M to +S, -S connections provide local sensing).

NOTES:

1. **+S and -S MUST be properly connected for the unit to operate. For local sensing, leave local sensing links in place (refer to PAR. 6.1). For remote sensing (at the load), refer to PAR. 6.2.**
2. **If remote ON/OFF is not being used, ±RC terminals must be connected (use shorting link supplied) for unit to operate.**

4.1 VOLTAGE ADJUSTMENT

Output voltage can be manually adjusted with the voltage adjustment control, V_{adj} (see Figure 6). To adjust voltage, first place the unit under an operating load, then monitor the (+)S and (-)S Sense terminals with a precision voltmeter and turn the voltage control to the desired operating value. Refer to Table 1 for the recommended Adjustment Range of all the RKW 1500W Models.

4.2 REMOTE VOLTAGE CONTROL

The unit is shipped with a shorting link in place between RV and REF terminals. Removal of this link allows the output voltage to be adjusted by either a trimmer pot (resistance) or by an external variable voltage source across the RV terminal and -S terminal.

NOTE: Specifications are met when voltage is within adjustment range in Table 1. If remote voltage control is not implemented, the shorting link between RV and REF must be in place.

Use either local sensing (PAR. 6.1) or remote sensing (PAR. 6.2). It is possible that the overvoltage protection may be triggered if the output voltage is manually (using RV control) decreased to a

low level very quickly when the power supply is at a low load condition. Remote sensing cannot be used for parallel operation, series operation and for remote voltage control.

RESISTANCE: Use a shielded wire 6.6 feet (2m) maximum in length, for connection (of REF, RV, and –S terminals) to the trimmer control. Connect the external trimmer as shown in Figure 7 (A). Suggested value for the trimmer control is 5K ohms). With the external trimmer control at its maximum clockwise position, set the output voltage to the desired maximum value by adjusting Vadj clockwise. The value should range from 0 to 120% of Eo nominal (from 0 to 110% for the 48-volt

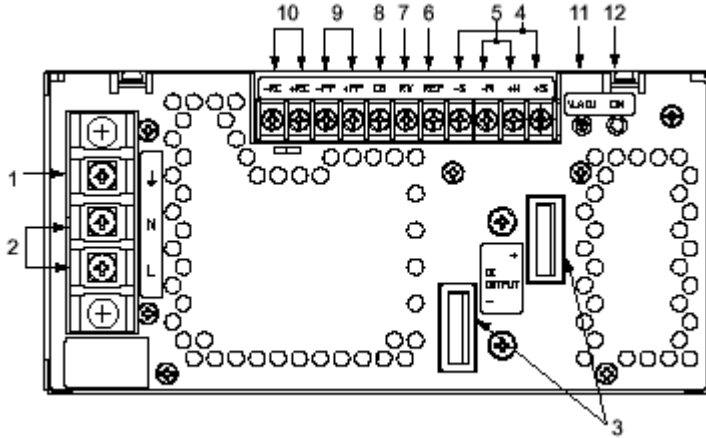

NOTE Unit is shipped with shorting links (not shown) connecting +RC to –RC (see PAR. 4.3) and REF to RV (see PAR. 4.2) and with local sensing links installed (connects +M to +S and –M to –S) (see PAR. 6.1). See PAR. 6.2 for remote sensing.

FIGURE 6. LOCATIONS OF OPERATING CONTROLS, INDICATORS AND TERMINALS

TABLE 3. FUNCTION OF CONTROLS, INDICATORS AND TERMINALS

FIG. 6 INDEX NO.	CONTROL, INDICATOR, TERMINAL	FUNCTION
1	Frame Ground (earth)	Connect to earth ground. This terminal is connected to the case.
2	A-C Input (L, N)	Connect to AC: 100 to 240V input line.
3	D-C Output (+, –)	Connect to load (see Figure 8).
4	Sense (+S, –S)	Used to compensate for voltage drop in the connecting lines from the output terminal to a load; they are connected to $\pm M$ terminals for local sensing (see Figure 8).
5	+M, –M Output Voltage Monitor	Used to connect output measurement device. Normally connected to sense terminals (S+, S–) via shorting link for local sensing
6	Output Voltage Reference (REF)	Using REF terminal (together with the RV terminal) allows all the output voltages of slave power supplies to be controlled by one voltage adjustment of a master power supply (normally connected to the RV terminal with a metal shorting link).
7	Output Voltage Adjust (RV)	This terminal (together with the REF terminal) is used for remotely controlling output voltage (see PAR. 4.2).
8	Current Balance (CB)	This terminal is used when several power supplies are connected in parallel (see PAR. 6.3).
9	Power Failure (PF)	These terminals output an open logic signal if output voltage drops to 80 % or lower of a set voltage, or if output voltage is shut down due to overvoltage or overcurrent protection, fan speed failure, or overheating. (see Figure 3).
10	Remote ON-OFF (+RC, –RC)	Output is turned ON-OFF by opening-shorting the RC terminals (output OFF when open). RC terminals are isolated from input and output terminals. Normally, $\pm RC$ terminals are shorted with a metal shorting link (see PAR. 4.3).
11	Output Voltage Trim Adjust (Vadj)	Adjusts output voltage.
12	Output Voltage On indicator (green)	Green LED lights when output voltage is present.

model, and for the 3-volt model). The remote voltage control may not be able to go down to zero volts because of the residual resistance of the potentiometer (could be about 10%).

VOLTAGE. By adjusting an external 0-6V voltage source (0-5.5V for the 48-volt model, the 3.3-volt model can be adjusted to 3.6V) from minimum to maximum, the maximum output voltage can be adjusted from 0 to 120% (V) (for the 48 volt models 110%). Remove the shorting link between the REF and RV terminal. Connect the voltage source across the RV and (-)S terminals as shown in Figure 7 (B).

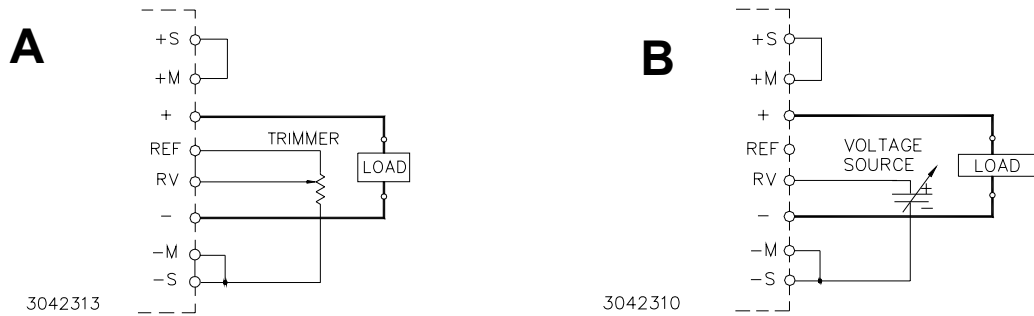

FIGURE 7. CONNECTIONS FOR REMOTE VOLTAGE CONTROL

4.3 REMOTE TURN ON-TURN OFF

When power is ON at the source, the output may be turned ON or OFF with the remote control feature using the \pm RC terminals (see Figure 6). These terminals accept a logic level (2.4V to 24V "high" and 0.0 to 0.4V "low"), or a contact closure. When the \pm RC terminals are open, using either a mechanical switch or a high level logic signal, the RKW 1500W output is cut OFF. When the RC terminals are shorted, the output returns to within specifications. At low level logic, the maximum source current is 1.6mA and at high level the sink current is 1.0mA. The RC terminals must remain shorted if remote ON-OFF is not used. The RC terminals are isolated from both the AC input and DC output terminals.

5. ALARM FUNCTIONS

5.1 OVERVOLTAGE AND OVERTEMPERATURE PROTECTION

When the output voltage of the RKW 1500W Power Supply increases beyond the specified values (see Table 1), the output is cut OFF and the fan turns OFF. Overvoltage setting tracks output voltage up to maximum specified in Table 1. To restart (reset) the unit, remove AC input power, wait about 40 seconds, then reconnect AC input power; or open the RC terminals and then reclose the terminals.

When the internal temperature of the RKW 1500W Power Supply increases beyond the specified values (see Table 1), the output is cut OFF and the fans turn OFF. The restart cycle (Power ON) should not begin until the temperature returns to within specifications. To restart (reset) the unit, remove AC input power, wait about 40 seconds, then reconnect AC input power. The power supply cannot be reset by using the remote ON-OFF feature unless the power supply is first shut down for about 40 seconds and then turned on again.

The alarm circuit is a diode transistor optical coupler. The transistor is normally conducting. When the alarm is activated, the transistor cuts off and the collector emitter circuit is open (see Figure 2)

5.2 OVERCURRENT PROTECTION

The output characteristic of the power supply is a square type, and the unit is set to shut down if output current exceeds specifications (see Table 1) for more than 30 seconds. To restart (reset) the unit, remove AC input power, wait about 40 seconds, then reconnect AC input power. or open the RC terminals and then reclose the terminals. (see PAR. 4.3).

5.3 FAN FAILURE

A cut off of the rotation supply voltage causes the output to shut down and the fans to turn OFF. Fan failure and all the other protection circuit operations are indicated by an open circuit across the (\pm) PF terminals. To restart (reset) the unit remove the AC input power, wait about 40 seconds, then reconnect AC input power; or open the RC terminals and then reclose the terminals. If fan rotation is out of specification the power supply will not recover

5.4 UNDERVOLTAGE

If the output voltage of the power supply falls below 80 percent of the programmed voltage the power failure alarm will go to the high logic state. Sink current is 2ma maximum and collector emitter voltage is 40 volts maximum. The \pm P/F terminals are insulated from AC input terminals and the DC output terminals. Insulation resistance between the \pm P/F terminals and the output terminals is the same as insulation resistance from output to ground of the power supply. Insulation resistance between the AC input terminals and \pm P/F terminals is the same as insulation resistance from the input terminals to the output terminals of the power supply.

6. LOAD CONNECTION

6.1 CONNECTING THE LOAD USING LOCAL SENSING

To connect the load for local sensing, (the sensing links are installed at shipping) connect the +S to +M terminals and -S to -M terminals. The load is connected across DC output (+) and (-) bus bars (see Figure 8).

6.2 CONNECTING THE LOAD USING REMOTE SENSING

For remote sensing the load is connected as shown in Figure 8. Remote error sensing at the load terminals compensates for a voltage drop in the connecting wires as indicated in Table 2. For remote sensing, the sensing links must be removed from the +S to +M and -S to -M terminals. NOTE: If oscillations set off the overvoltage protection, install one external electrolytic capacitor, rated 470 μ F min. between the +M and +S terminals and one between the -M and -S terminals.

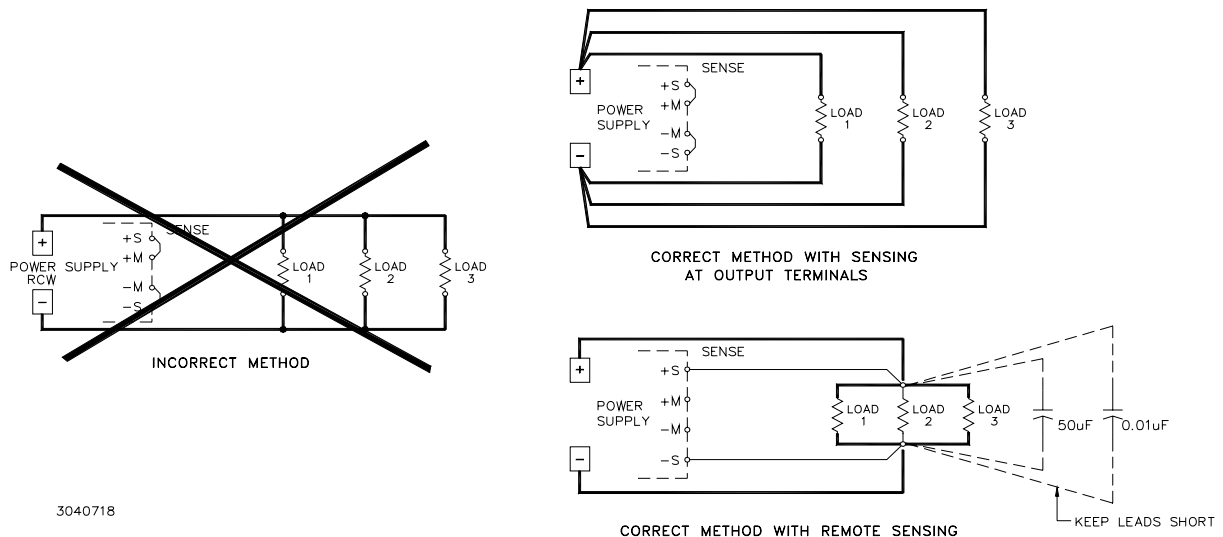

FIGURE 8. CORRECT AND INCORRECT METHODS OF LOAD CONNECTION

6.3 PARALLEL CONNECTION

RKW 1500W Power Supplies can be connected in parallel (with or without N+1 redundancy). Use twisted or shielded wire for connection to RV and -S terminals. The impedance of the load wires between each power supply and load should be the same.

For a single remote ON-OFF signal to turn off all parallel-connected units, connect together all +RC terminals and connect together all –RC terminals. Figure 9 illustrates connection of up to four (maximum) power supplies in parallel.

N+1 Redundancy. An N+1 system requires one additional power supply than necessary to supply the load. If one of the parallel-connected units fail, the others will continue to provide power to the load without down time. For redundancy, add isolation diodes as shown in Figure 9.

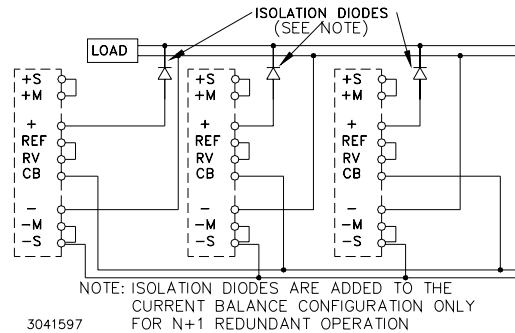

FIGURE 9. PARALLEL CONNECTION WITH CURRENT BALANCING

6.3.1 CURRENT BALANCING

Current equalization conditions required for up to four RkW 1500W units in parallel are:

1. Output current of each power supply should be within 20 to 90% of the total output current rating.
2. The output voltage of any Power Supply individually must be within 2% maximum of the other power supply output voltage setting.

$$\frac{\text{Maximum Voltage} - \text{Minimum Voltage}}{\text{Rated Voltage}} = 2\% \text{ variation of output voltage in each power supply}$$

3. The expected current sharing is such that the output current variation for each power supply is less than or equal to 10% of each power supply rated output current.

6.3.2 MASTER-SLAVE CONFIGURATIONS

Master-slave operation allows the output voltage of all the power supplies connected in parallel to be adjusted at the same time by using the Vadj control on the designated master power supply.

6.3.2.1 MASTER-SLAVE, MULTIPLE LOADS

Figure 10 shows the master-slave connection of three power supplies in parallel, each having an independent load, with output voltage controlled by the Vadj control of the master power supply. Use shielded wire (recommended) or twisted wires for connections to RV and –S terminals.

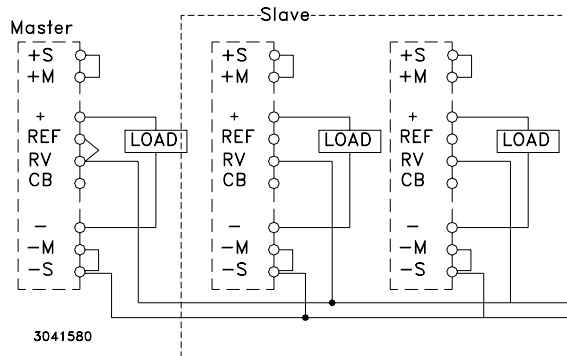

FIGURE 10. PARALLEL CONNECTION, MASTER-SLAVE, MULTIPLE LOADS

6.3.2.2 MASTER-SLAVE, SINGLE LOAD

Figure 11 shows the connection of three power supplies in parallel to a single load. The output voltage of all power supplies is controlled by V_{adj} of the master. Current balancing is implemented to equalize the load current (see PAR. 6.3.2). NOTE: Use shielded wire (recommended) or twisted wires for connections to RV and -S terminals. Match impedance of load wires between each power supply and load by using the same wire lengths and wire sizes.

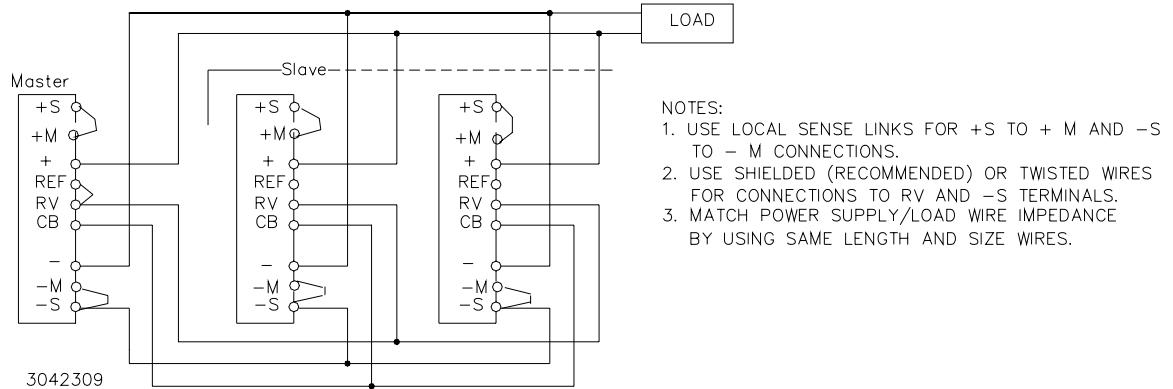

FIGURE 11. PARALLEL CONNECTION, MASTER-SLAVE, SINGLE LOAD

6.4 SERIES CONNECTION

Units may be connected in series to obtain higher voltages. When a number of power supplies are operating in series, the current rating is to be limited to the rating of the power supply with the lowest rating. Each Power Supply in series should be protected by a diode connected in parallel with the output as shown in Figure 12. The diode protects against reverse voltages. It should be rated for typically, $V_{REVERSE} \geq 2 \times \Sigma V_{OUT}$ of the series connection, $I_{FORWARD} \geq 2 \times I_{OUT}$ of the series connection).

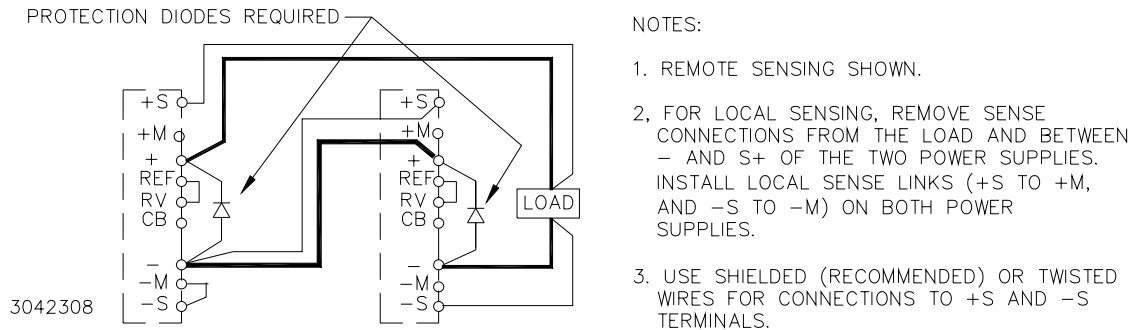

FIGURE 12. SERIES CONNECTION

6.5 PRELIMINARY ELECTRICAL CHECK

Connect an adjustable load across the power supply output bus bars, on the right side of the front panel (see Figure 6). The load must have a dissipation rating of at least 3000 Watts. Connect a voltmeter and an oscilloscope across the power supply monitor terminals (should be linked to the respective sensing terminals, +S and -S). The oscilloscope must be isolated from the source and grounded at the load. Use an isolation transformer between the test equipment and the AC input power (see Figure 13).

Connect the AC input power to the line, neutral and ground terminals (see Figure 6). Turn source power on and check the output voltage both with and without load. The output voltage can be adjusted within the published range by using the front panel voltage control trimmer V_{adj}

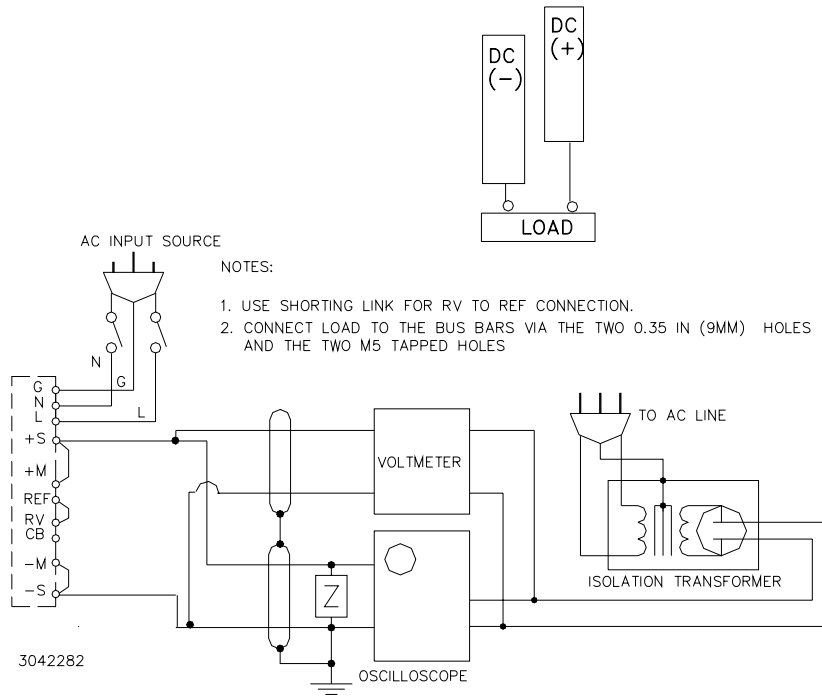

FIGURE 13. FUNCTIONAL CHECKOUT

7. FAN MAINTENANCE

Under most conditions the fans requires no maintenance. Do not use the fans in an environment of high temperature and high humidity that exceeds the temperature and humidity limits given in the Power Supply Specifications (see Table 2). Avoid an environment where corrosive gas may be present. If the Power Supply is used in an open or dirty area, a filter should be installed on the air intake side of the fans to prevent the inflow of dust particles. If the Power Supply is used in briny air care should be taken to keep the salt from entering the Power Supply.

You must register your product to comply with the terms of the warranty. Either fill out the form below and mail or fax to Kepco, or for rapid on-line registration go to:

<http://www.kepcopower.com/warranty.htm>

PRODUCT PURCHASED:

Model Number) _____

Serial Number _____

PURCHASE INFORMATION:

Date Purchased: _____

Date Received: _____

REQUEST ADDITIONAL INFORMATION

Send complete Catalog

Have Sales Engineer Call

Contact via: E-Mail Telephone Fax S-mail

REGISTER TO:

Registered by: _____

Company Name: _____

Street: _____

City: _____

State: _____

Country: _____

Zip: _____

E-mail: _____

FAX: _____

Phone: _____

WHAT INFLUENCED YOUR CHOICE OF THIS POWER SUPPLY?

Previous Experience (which Kepco Models do you have?) _____

Magazines (which ones?) _____

Trade Shows (which ones?) _____

Directory? _____

Kepco Catalog or Brochure? _____

Sales Representative?

Web Site

Other (please explain): _____

What products would you like to see Kepco make?

CUT HERE

Kepco 5 Year Warranty

This is to certify that we, KEPCO, INC., (hereinafter called "Company"), Flushing, NY 11355 USA, warrants for a period of FIVE YEARS, this instrument known as:

MODEL: _____

SERIAL NO. _____

The Company's products are warranted for a period of five years from date of delivery to be free from defects in materials and workmanship and to conform to the specifications furnished or approved by the Company. Liability under this warranty shall be limited to the repair or replacement of any defective product at Company's option.

If any defect within this warranty appears within the warranty period, the Purchaser shall promptly notify the Company in writing. No material will be accepted for repair or replacement without written authorization of the Company.

Upon such authorization, and in accordance with instructions of the Company, parts or materials for which replacement is requested shall be returned to the Company for examination, with shipping charges prepaid by the Purchaser. Final determination as to whether a product is actually defective rests with the Company.

This warranty does not extend to any product which has been subjected to misuse, neglect, accident, improper installation, or use in violation of instructions furnished by the Company. The warranty does not extend to, or apply to, any unit which has been repaired or altered outside of the Company's factory by persons not expressly approved by the Company.

THE WARRANTY HEREIN CONTAINED IS IN LIEU OF AND EXCLUDES ALL OTHER WARRANTIES, EXPRESS, IMPLIED OR STATUTORY, INCLUDING WITHOUT LIMITATION THE WARRANTY OF MERCHANTABILITY.

THIS KEPCO PRODUCT IS WARRANTED FOR FIVE YEARS!

KEPCO, INC. • 131-38 SANFORD AVENUE, FLUSHING, NY 11355 USA • Tel. 718-461-7000 • Fax. 718-767-1102
E-mail: hq@kepcopower.com • URL: <http://www.kepcopower.com>



FOLD HERE

Please
place
stamp
here

KEPCO, INC.

131-38 SANFORD AVE.
FLUSHING, NY 11355 USA

CUT HERE