

INSTRUCTION MANUAL



KEPCO An ISO 9001 Company.

**KIT
219-0433**

CHASSIS SLIDES KIT NO. 219-0433

1. DESCRIPTION

This Kepco KIT contains the components required to install chassis slides on Kepco RA 58 or RA 60 Rack Adapters

2. INSTALLATION OF CHASSIS SLIDES

2.1 MATERIAL REQUIRED (SEE TABLE 1.)

TABLE 1. MATERIAL REQUIRED

MATERIAL	LOCATION	QUANTITY
Slide (includes cabinet and chassis sections), Kepco P/N 108-0318 (Jonathan P/N 110QD-18-1)	Provided in this Kit	2
End Bracket, Kepco P/N 128-1849 (Jonathan P/N SPO-440-Z)	Provided in this Kit	4
Screw 10-32 x 3/8 in. long, BHPH, cadmium/yellow plated Kepco P/N 101-0311	Provided in this Kit	16
Nut, 10-32 Kepco P/N 102-0008	Provided in this Kit	8
Washer, flat #10 Kepco P/N 103-0031	Provided in this Kit	8
Washer, Internal lock, #10, Kepco P/N 103-0019	Provided in this Kit	8

2.2 PROCEDURE (SEE FIGURES 1, 2 AND 3.)

1. Attach two chassis sections of slide (108-0318) to each side of rack adapter using eight screws (101-0311) (see Figure 1).

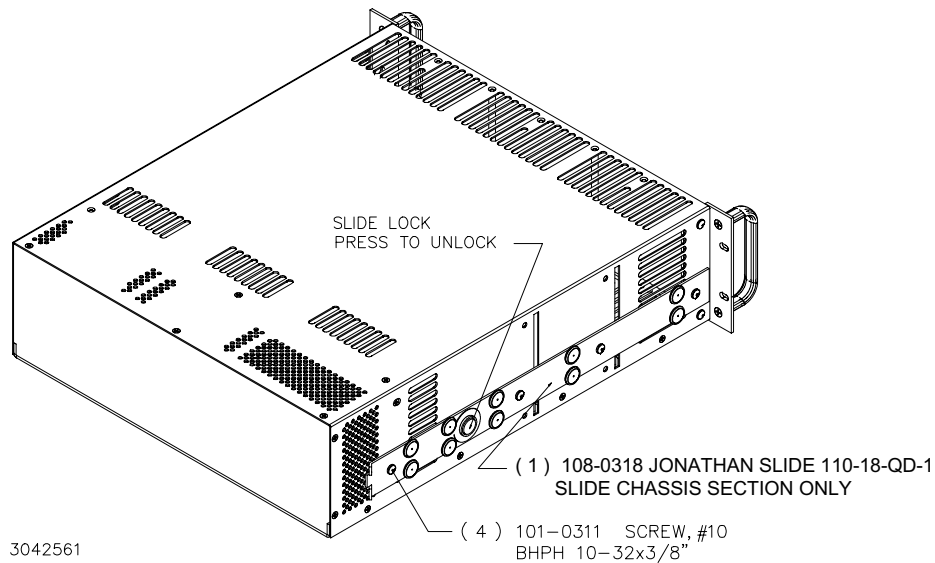
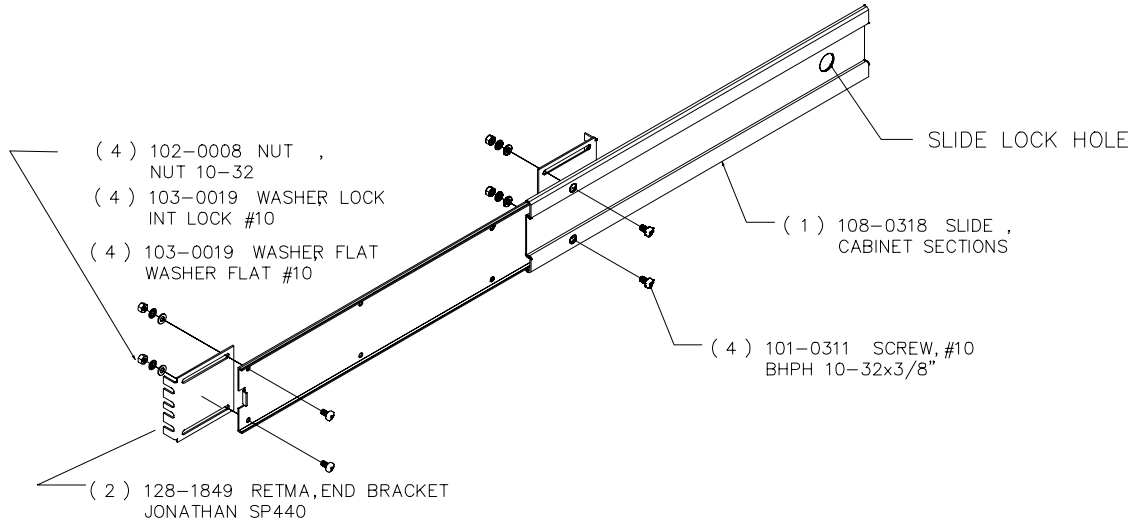

FIGURE 1. INSTALLING CHASSIS SLIDES ON RACK ADAPTER

KEPCO, INC. ● 131-38 SANFORD AVENUE ● FLUSHING, NY. 11352 U.S.A. ● TEL (718) 461-7000 ● FAX (718) 767-1102
<http://www.kepcopower.com> ● email: hq@kepcopower.com

- Attach four end brackets (128-1849) to the two cabinet sections of slides (108-0318) using eight screws (101-0311), flat washers (103-0031), lockwashers (103-0019), and nuts (102-0008) (see Figure 2).



3042604

FIGURE 2. ATTACHING END BRACKETS TO SLIDE (CABINET SECTION)

- Attach mounting brackets (with cabinet section of slide attached) to the cabinet rail (attaching hardware not supplied) (see Figure 3).

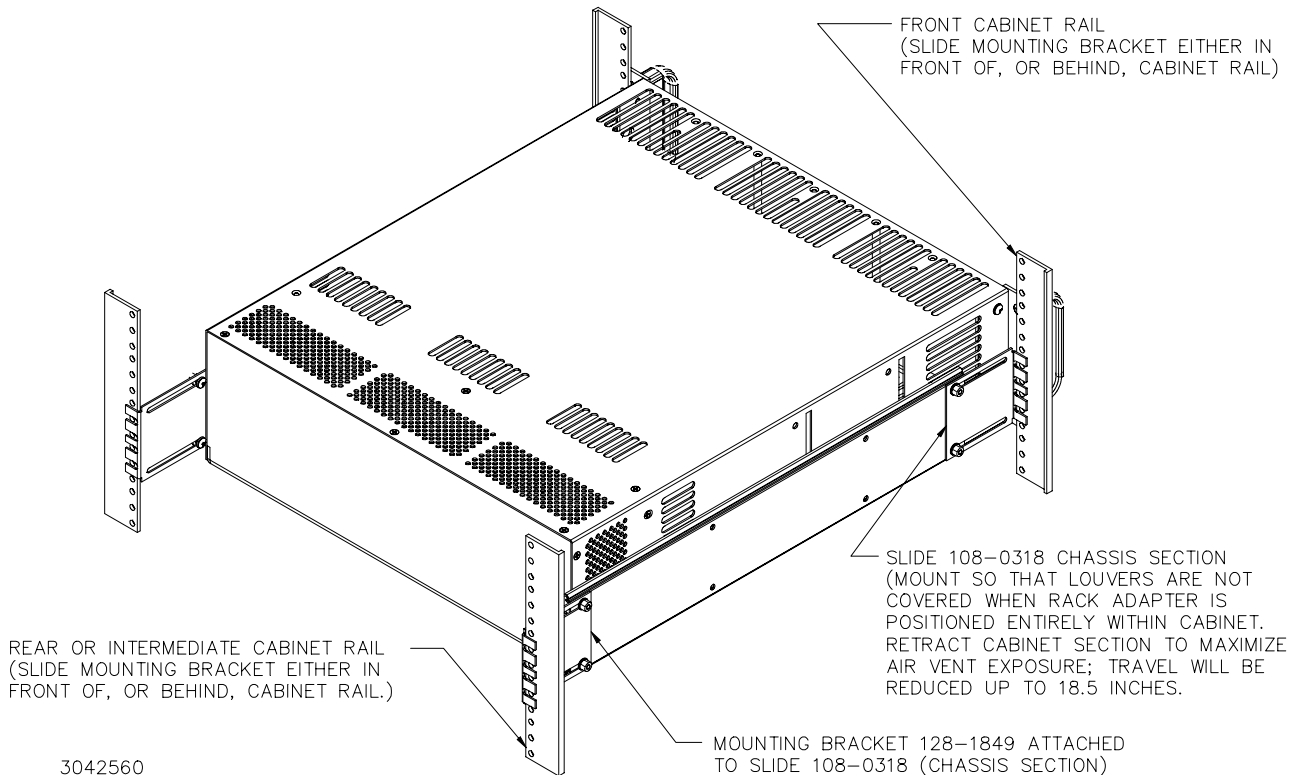

3042560

FIGURE 3. ATTACHING CABINET SECTION TO RAIL

- Insert rack adapter into rack (insert chassis-mounted slide section into the cabinet mounted slide section).