

INSTRUCTION MANUAL

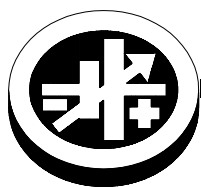

KEPCO An ISO 9001 Company.

HSF-1U
100W

**KEPCO SINGLE OUTPUT, 1U, 100 WATT
HOT SWAP PLUG-IN POWER SUPPLIES** (CE)

I — INTRODUCTION

The Kepco HSF-1U 100 Watt Series hot swappable, high frequency switching, plug-in power supplies employ forward conversion and are designed to operate in a fault tolerant power system with either a-c or d-c input. A thermistor soft-start circuit limits start-up surge. A built-in forced current share circuit and OR-ing diodes allow configuration for hot-swap and parallel-redundant N+1 operation.

These power supplies are designed to be used with Kepco's Series RA 19-1U rack adapters. The RA 19-1U rack adapter accepts up to four 50 Watt or 100 Watt units (see Figure 1). All input/output connections are through a 24-pin connector that plugs in to the rack adapter. All external connections are made through the rack adapter. Surface mount technology permits efficient component layout for minimum mounting space.

Six models may be selected for outputs of 5, 12, 15, 24, 28, or 48V (see Table 1).

When the input is cut off, the output is maintained for 15 milliseconds minimum. If the power supply shuts down due to an output overvoltage condition, it is then necessary to wait 60 seconds minimum before turning the unit on again. EMI filtering is designed to meet FCC Class B rating and VDE 0871 Class B rating. This page contains specifications for each model of the HSF-1U 100 Watt Series. Environmental specifications for each model are the same.

TABLE 1. OUTPUT RATINGS AND SPECIFICATIONS, HSF-1U 100W SERIES

MODEL		HSF 5-20-1U	HSF 12-8.3-1U	HSF 15-6.6-1U	HSF 24-4.2-1U	HSF 28-3.5-1U	HSF 48-2-1U
OUTPUT VOLTS, d-c (NOMINAL)		5.0V	12.0V	15.0V	24.0V	28.0	48.0
ADJUSTMENT RANGE		4.5 - 5.5V	11.4 - 12.6V	13.5 - 16.5V	22.5 - 25.5V	26.5 - 29.5V	45 - 51V
OUTPUT CURRENT (NOMINAL) ⁽¹⁾		20.0A	8.3A	6.6A	4.2A	3.5A	2.0A
OUTPUT POWER (NOMINAL) ⁽²⁾		100.0W	99.6W	99W	100.8W	96W	96W
RIPPLE AND NOISE (mV p-p) 0-40°C 10-100% LOAD	source (typ)	10	15	15	25	30	30
	source (max)	20	30	30	30	60	60
	switching (typ)	30	35	40	50	60	80
	switching (max)	65	70	80	110	140	220
	spike noise (d-c—50MHz)	120	190	220	310	330	530
OVERVOLTAGE SETTING 25°C, NOM. INPUT		6.5 - 7.5V	13.7 - 15.7V	17.0 - 19.0V	27.0 - 30.5V	32.0 - 35.0	53.5 - 60.0
OVERCURRENT SETTING 25°C, NOM. INPUT Rectangular type characteristic		21.0 - 24.0A	8.7 - 10.0A	7.0 - 8.0A	4.4 - 5.2A	3.7 - 4.2A	2.1 - 2.4A

- (1) Derates same as Output Power.
(2) See power derating curve, Figure 4.

II — FEATURES

FRONT PANEL ACCESS. The front panel provides a power ON/OFF switch controlling input power and a "VDC ON" light which lights green when the unit is operating normally or red when the fan is inoperative and jumper J1 is installed (see III - ALARMS). **NOTE: The ON/OFF switch must be set to OFF before removing unit from rack adapter.** The front panel "MASTER ON" LED lights when 1) the unit operates independently, or 2) the unit is used in parallel redundant configurations while a) the output is less than 10% of nominal or b) the output is within 10% to 100% of nominal and the unit is functioning as a master. In parallel redundant configurations, the module with the highest voltage functions as the master. The other units are slaves, and track the output voltage of the master. Refer to **Current Share Bus (CSB)** on page 3 for details. The front panel Vadj trimmer provides adjustment of the output voltage within the limits specified in Table 1; test points connected to the +S and -S lines are available at the front panel for measuring the output.

FORCED CURRENT SHARE CIRCUIT. When units are configured for N+1 parallel redundant operation, it is desirable for current to be divided equally among the paralleled supplies. When the CSB (Current Share Bus) lines of paralleled HSF-1U units are connected together, the load current is forced to divide equally between all paralleled units. If one unit fails, the remaining units will continue to supply the load, and the load current will be divided equally among the remaining operating units. The failed unit is automatically isolated from the circuit by a built-in isolation diode. Refer to **Current Share Bus (CSB)** on page 3 for details.

KEPCO, INC. • 131-38 SANFORD AVENUE • FLUSHING, NY. 11352 U.S.A. • TEL (718) 461-7000 • FAX (718) 767-1102
http://www.kepcopower.com • email: hq@kepcopower.com

ALARM CIRCUIT. The HSF-1U includes an isolated internal relay offering normally closed and normally open contacts referenced to an isolated common. These contacts may be used to configure “close on failure” or “open on failure” alarm circuits. An alarm is triggered by either voltage or fan failure. (Refer to the RA 19-1U Manual for alarm configurations for multiple HSF-1U power supplies.) For details refer to Section III - ALARM.

KEYING. Keying of the HSF-1U is established at the factory. The output voltage determines which key pins are installed. When the proper holes in the rack adapter are blocked by keying screws installed by the user, only a power supply of the correct voltage can be inserted in the rack adapter slot. (Refer to the RA 19-1U Manual for rack adapter keying instructions.)

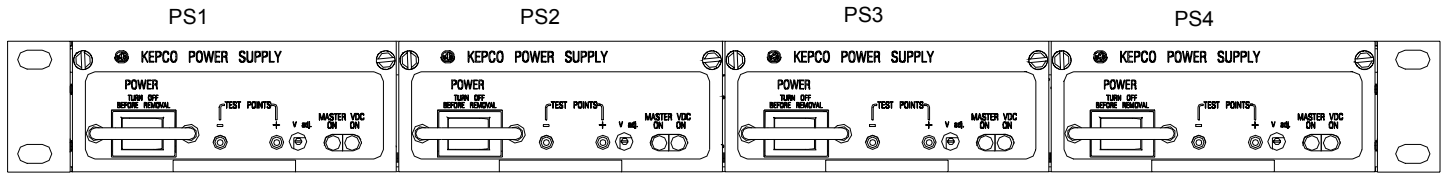

3042496

FIGURE 1. HSF-1U 100 WATT POWER SUPPLIES (4) INSTALLED IN RA 19-1U RACK ADAPTER

III — SPECIFICATIONS

The following specifications apply to HSF-1U 100 Watt Series models (also refer to Table 1). Other models are also available; consult your Kepco representative for their specifications.

INPUT:

Voltage: 120V a-c/240V a-c nominal; Range 85-264V a-c; 125-370V d-c. (polarity insensitive; consult factory)
 Frequency: Nominal 50-60 Hz; Range 47-440Hz (at 440Hz leakage current exceeds UL/VDE safety spec.limit).
 Current (nominal output at rated load): @120V a-c rms: 1.0A a-c typ., 1.2A a-c max;
 @240V a-c rms: 0.5A a-c typ., 0.7A a-c max.

Initial Turn-on Surge: (one-half of first input cycle): @120V a-c rms, 45A max., @240V a-c rms, 90A max.

Brownout Voltage: 85V a-c, 110V d-c

Switching Frequency: 120KHz typical, nominal load

STABILIZATION:

Source Effect: Range 95-132V a-c or 190-264V a-c, 1.0% typ.; 2.0% max.

Load Effect: Range 10%-100% load, 1.0% typ.; 2.0% max.

Temperature Effect: Range 0° to 40°C, 1.0% typ.; 2.0% max.

Combined Effect: 2.0% typ.; 4.0% max. (includes source, load, and temperature effects).

Time Effect: 0.1% typ.; 0.5% max. (1/2 hr-8 hr at 25°C).

RECOVERY CHARACTERISTICS: A step load change from 50% to 100% produces less than ±4% output excursion. Recovery occurs to within ±1% of the original setting in <2 ms (load change t_r or t_f equal to or greater than 50µsec).

START-UP TIME: 500 ms. maximum.

HOLDUP TIME: 20 ms. typ. (120V a-c), 15 ms. min (100V a-c).

DIELECTRIC STRENGTH:

Between input and output: 2KV a-c for one minute.

Between input and output with Y-capacitor removed: 3.75KV a-c for one minute.

Between input and case (ground): 2KV a-c for one minute.

INSULATION RESISTANCE: Between input and ground, output and ground, input and output;
 100 Megohms min. (500V d-c).

LEAKAGE CURRENT

(UL method, 120V a-c): 0.5 mA maximum.

(VDE method, 240V a-c): 0.75 mA maximum.

SAFETY: Designed to meet UL 1950; CSA 22.2 No. 234 (M90) Level 3, EN 60950 Units are CE marked per the Low Voltage Directive (LVD), 73/23/EEC and 93/68/EEC. [The standards do not apply with DC input operation]

I/O CONNECTOR: The 24-pin I/O connector (Figure 2) is designed to mate with the corresponding connector in the RA 19-1U Rack Adapter.

(+) SENSE, (-) SENSE: These lines are provided to compensate for voltage drops in the load connecting wires. The Sense lines must be connected to their respective (+) and (-) output terminals, either at the load (local) or at the rack adapter (remote); see the Rack Adapter Manual. The connection ensures the most accurate error tracking. Error compensation in the connecting wires is up to 0.25 Volts per lead for all models.

NOTE:

The Sense lines must be connected for the HSF-1U Power supply to work properly! Ripple and noise at the load may increase if remote error sensing or if long connecting wires are used; this can be reduced by using twisted and shielded sense and load wires, additional filter capacitors at the load and by proper grounding at either the load or power supply terminal with just one ground point in the system.

OUTPUT (+), OUTPUT (-): HSF-1U power supply d-c output.

CURRENT SHARE BUS (CSB): Connecting the CSB lines of HSF-1U power supplies operating in a parallel configuration causes output current to be shared equally. (See Rack Adapter Manual for additional information on parallel configurations.). For current sharing to work properly the outputs of all paralleled units must be within 250 mV (max) of each other and each unit must be operating at between 10% to 100% of rated output. If current to the load goes below 10% for each unit in current share mode, all MASTER ON lights may go on (see load effect specifications); this indicates that forced current share is no longer working, units are simply in current share mode. (If forced current sharing at less than 10% nominal current per supply is needed, contact Kepco application engineering.) Remote sensing is recommended. For master/slave operation to work properly each unit should be adjusted to 40 mV (optimum) less than the next paralleled unit (unit 1 is adjusted to V_{OUT} , unit 2 to $V_{OUT} - 40mV$, and unit 3 to $V_{OUT} - 80mV$, etc. If the master fails, the unit 2 will become the new master). The 40 mV difference can be reduced to a minimum of 25 mV as needed to parallel many units and still keep all units within 250 mV of each other. Adjust the outputs using Vadj trimmer on front panel.

- Optimum difference among output voltages of paralleled units: 40mV
- Maximum difference among output voltages of paralleled units: 250 mV
- Minimum difference among output voltages of paralleled units: 25 mV

ALARM: The Alarm NC (normally closed) - Open on Failure and Alarm NO (normally open) - Close on Failure lines are relay contacts referenced to Alarm Common. If the unit fails, the path between Alarm NC - Open on Failure and Alarm Common opens, the path between Alarm NO - Close on Fail and Alarm Common is a short circuit. Figure 3 illustrates typical Close on Fail and Open on Fail circuits to provide an alarm for a failure of a single unit fail; refer to RA 19-1U manual for complete information regarding other configurations. Units are shipped so that the alarm will trip and shutdown will occur upon overvoltage, open sense line and fan failure (fan failure shutdown can be disabled, see COOLING and Figure 5). The alarm will also trip upon undervoltage, however shutdown may not occur, depending on the load After shutdown occurs, 60 second delay (minimum) is required before turning the unit on again.

Forced shutdown upon fan failure can be disabled by installing a jumper, Kepco P/N 172-0382 (Digikey P/N A26231-N) as shown in Figure 5. This allows the unit to continue to operate with the fan inoperative (see Figure 4 for safe operating conditions); the alarm signals noted above will report an alarm condition, and the VDC ON indicator will either light red (fan supply voltage missing) or flicker between red and green (mechanical failure). With the jumper installed the user is responsible for either reducing the load to within the specifications given in Figure 4, or shutting down the unit using the alarm signals provided.

COOLING: Forced convection, ball-bearing fans, life expectancy 50,000+ hours. Natural convection can be used if the load does not exceed 60% of max. (see Figure 4). Simply disconnect the fan and install jumper J1 (see Figure 5); the alarm signals described above are disabled and VDC ON lights red; overvoltage and open sense line conditions still force unit shutdown. Contact Kepco's Applications Engineering for full-featured natural convection cooled units.

EMI: Designed to meet FCC Class B (100-120V a-c) and VDE 0871 Class B (220-240V a-c).

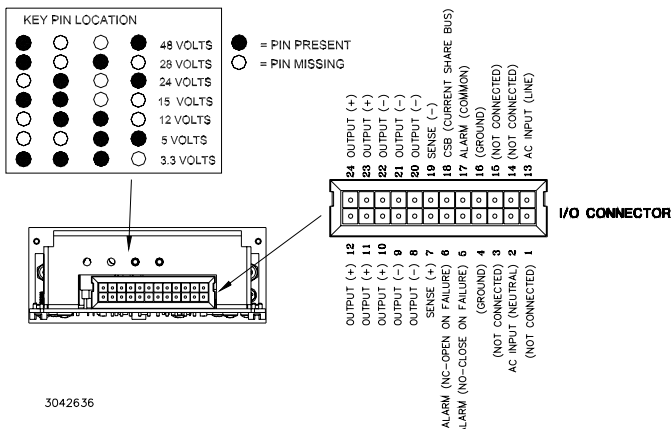

FIGURE 2. REAR CONNECTOR PIN ASSIGNMENTS

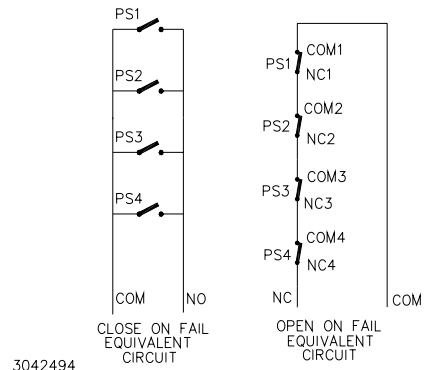

FIGURE 3. TYPICAL ALARM CIRCUIT DIAGRAMS

INPUT POWER: Line (either a-c or d-c source power), Neutral and Ground (chassis)

VIBRATION: (non-operating, one hour on each one of the three axes):
 5-10 Hz, 10 mm amplitude.
 10-55 Hz, 2g acceleration.

SHOCK: (non-operating, one-half sinusoidal pulse, three shocks to each axis):
 Acceleration: 20g
 Duration: 11ms ±5ms

OPERATING TEMPERATURE: See Figure 4.

STORAGE TEMPERATURE: -40°C to +75°C.

OPERATING AND STORAGE RELATIVE HUMIDITY: up to 95% (wet bulb temp. <35°C non-condensing).

FUSE: Quick acting 3.0A, 250V; (5.2 x 20mm), San-O P/N MT4 3A; Kepco P/N 541-0110.

DIMENSIONS: See Figure 5.

WARRANTY: 5 years.

OUTPUT POWER RATINGS

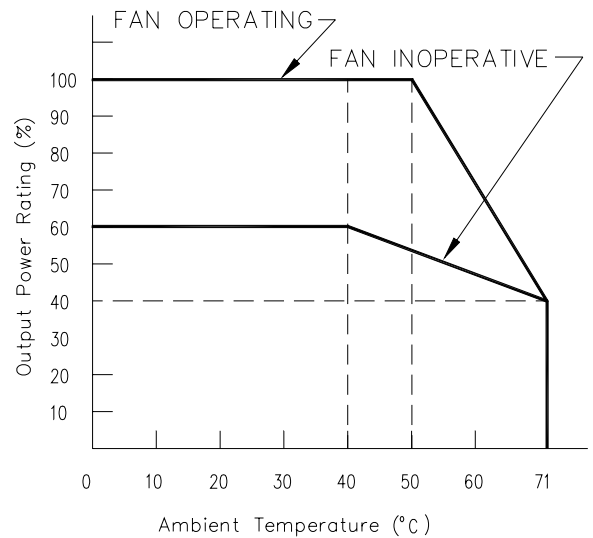

FIGURE 4. % OUTPUT POWER RATING VS. AMBIENT TEMPERATURE

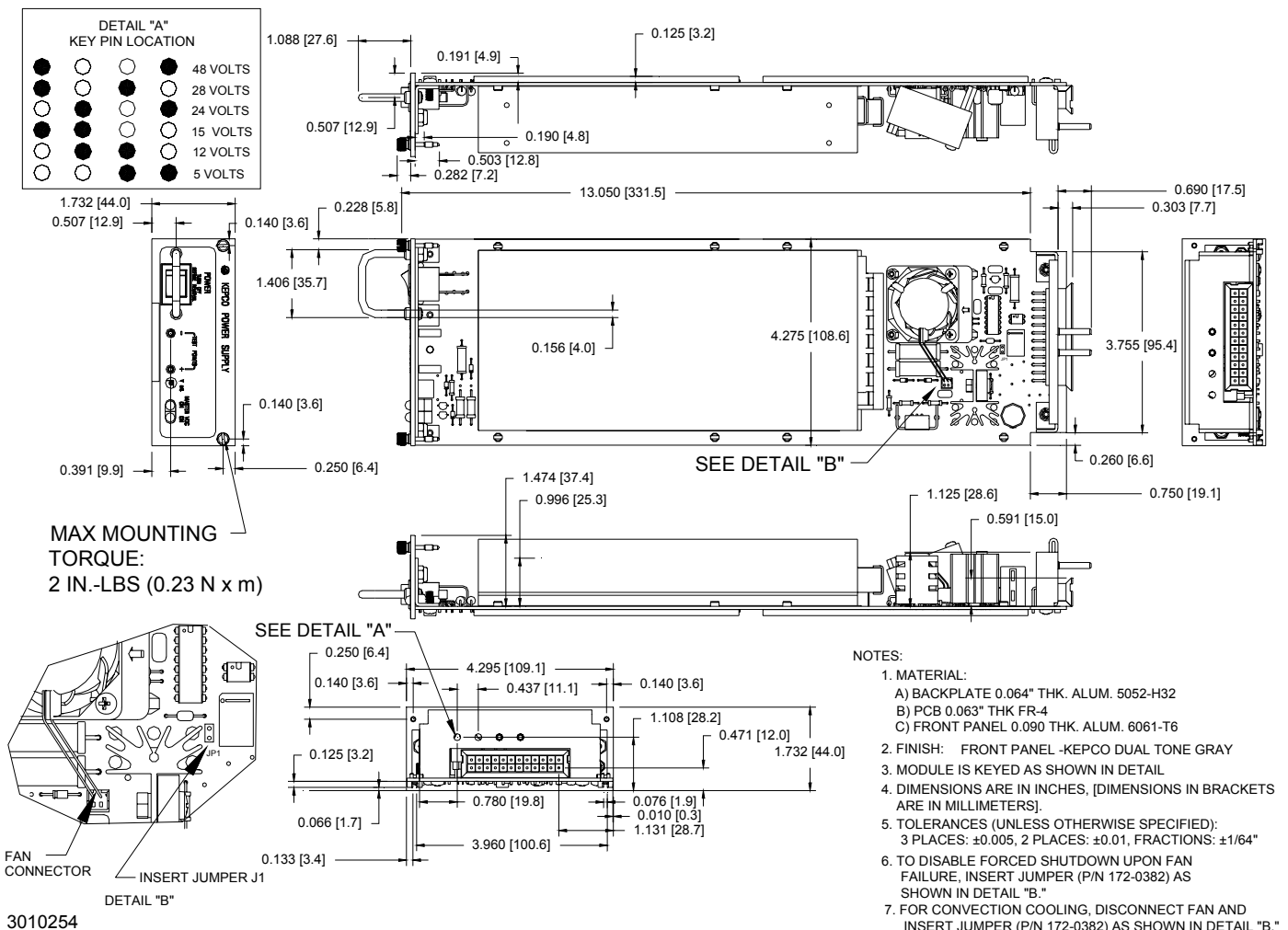

FIGURE 5. HSF-1U POWER SUPPLY OUTLINE DRAWING

KEPCO, INC. ● 131-38 SANFORD AVENUE ● FLUSHING, NY. 11352 U.S.A. ● TEL (718) 461-7000 ● FAX (718) 767-1102
 http://www.kepcopower.com ● email: hq@kepcopower.com