

INSTRUCTION MANUAL

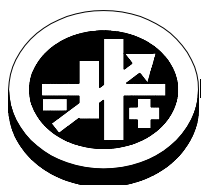

KEPCO An ISO 9001 Company.

RKW
50W SERIES



50 WATT SINGLE OUTPUT, PFC, OPEN FRAME POWER SUPPLIES

I – INTRODUCTION

SCOPE OF MANUAL. This instruction manual covers the installation and operation of the Kepco RKW 50W Series of Open Frame. PFC (Power Factor Corrected), RoHS (Reduction of Hazardous Substances) compliant switching power supplies.

DESCRIPTION. The Kepco RKW 50W Series consists of six models of switching power supplies, with a single output as shown in Table 1. Units may be operated with a nominal 100V a-c to 240V a-c (input voltage range 85 to 265 Va-c), 50-60 Hz (input frequency range 47-66Hz; units operate up to 440Hz although leakage current, power factor and efficiency specifications may not be met.) They will also operate on 110V to 370V d-c input. The RKW 50W Series employs a forward converter with a fixed switching frequency of approximately 140kHz. Power Factor Correction (PFC) is provided by a boost converter operating at 80kHz. Regulation is provided by pulse width modulation. A therm-

istor circuit prevents excessive turn-on current surge. Remote programming of output voltage using an external resistance can be implemented. Overvoltage and overcurrent protection is provided. Current limiting with automatic recovery from short circuit is featured. Units are convection cooled L-chassis construction. A steel cover (Model CA 34-R) is available as an option (contact factory for derating with cover).

Specifications and operating limits for individual RKW 50W models are listed in Table 1. Section II describes RKW 50W features. Section III contains specifications and operating limits common to all RKW 50W Series Models. Section IV describes installation and Section V describes operation.

TABLE 1. OUTPUT RATINGS AND SPECIFICATIONS, RKW 50W SERIES

MODEL		RKW 3.3-12K	RKW 5-10K	RKW 12-4.3K	RKW 15-3.5K	RKW 24-2.2K	RKW 48-1.1K
OUTPUT VOLTS, d-c		3.3V	5V	12V	15V	24V	48V
ADJUSTMENT RANGE, Vd-c		2.85-4.0	4.0-5.8	9.6-13.2	12-16.5	19.2-26.4	38.4-52.8
OUTPUT CURRENT (AMPS) -10 to +50 °C		12.5	10	4.3	3.5	2.2 ⁽⁵⁾	1.1
CURRENT LIMIT ⁽²⁾ (AMPS)		13.1 min	10.5 min	4.5 min	3.6 min	3.3 min	1.15 min
SHORT CIRCUIT CURRENT ⁽²⁾ (AMPS)		16.0	12.6	5.6	5.4	6.2	2.4
OVP SETTING ⁽¹⁾ (VOLTS)		4.2-5.2	6.0-6.9	13.7-15.7	17.0-19.0	27.0-30.5	55.0-60.0
EFFICIENCY	100 Va-c	71%	75%	78%	78%	79%	80%
	200 Va-c	73%	78%	80%	80%	82%	83%
RIPPLE AND NOISE ⁽³⁾ (mV p-p)	Switching ripple (typ)	80	80	100	100	100	130
	spike noise (typ) ⁽²⁾	120	120	150	150	150	200
External Potentiometer ⁽⁴⁾		1K Ohms	1K Ohms	2K Ohms	2K Ohms	5K Ohms	10K Ohms

- (1) An overvoltage shuts down the output. Recover by recycling a-c input (30 second delay required before resetting).
- (2) The current limit is rectangular. After the overload is removed, output is automatically restored.
- (3) Bandwidth 100 MHz. Ripple and noise will be approximately 1.5 times these values in the operating temperature range -10 ~ 0°C. The ripple and noise values tabulated are valid when the output is derated as shown in figure 2 from 50 ~ 65°C
- (4) Used for remote programming of output voltage. See Section IV OPERATION, REMOTE VOLTAGE PROGRAMMING.
- (5) Peak Current: 3.2A (useful for motor start applications). Thermal protection (24V model only) cuts off output voltage if overtemperature detected; after sufficient cooling, recover by cycling a-c input.

II — FEATURES

- Green Output on LED indicator
- Remote Error Sensing
- Overvoltage/Overcurrent protection
- Power Factor Corrected, wide range a-c input
- Convection cooling

- SEMI-47 compliant
- RoHS compliant
- DIN-Rail mountable
- Remote Voltage Programming
- Parallel/Series Operation

III — SPECIFICATIONS

The following specifications are at nominal input voltages at 25°C unless otherwise specified.

INPUT:

Voltage: 100-240V a-c nominal; Range 85-265V a-c (0 to 100% load, -10 to 71°C); 110-370V d-c. (polarity insensitive; consult factory) Safety agency approval applies only to a-c input operation.

Frequency: Nominal 50-60 Hz; Range 47-440Hz (0 to 100% load, -10 to 71°C), (at 440Hz leakage current exceeds UL/VDE safety specification limit).

Current (nominal output at 100% load):

@100-120V a-c rms:

5V - 48V models: 0.8A a-c rms max.
3.3V model: 0.7A rms max.;

@200-240V a-c rms:

5V - 48V models: 0.4A a-c rms max.
3.3V model: 0.35A rms max.;

Input Protection and Soft Start: Thermistor circuit reduces start-up surge. Units are protected against shorts by an input fuse. Fuse value 2A, 250V (Littelfuse P/N: 215002PG, Kepco P/N 541-0040).

Initial Turn-on Surge: (cold start 25 °C, first surge only, not including the current flow into the EMI filter):

@100V a-c rms: 14A typ.,
@200V a-c rms: 28A typ.

Switching Frequency: 140kHz typical, PFC boost converter: 80kHz typical, nominal load

LEAKAGE CURRENT:

@120V a-c and 60 Hz: 24mA max, 0.15mA typ.
@240V a-c and 60 Hz: 0.48mA max, 0.30mA typ.
(operating in conformance with UL 1950/IEC 950)

POWER FACTOR:

@100V a-c: 0.99 typ.
@200V a-c: 0.95 typ.

STABILIZATION:

Source Effect (Range 85 to 132Va-c or 170-265 Va-c): 0.1% typ., 0.2% max.

Load Effect measured at sensing terminals (0% - 100% of rated output current): 0.1% typ., 0.4% max.

Temperature effect (-10 to 71°C): 0.5% typ., 1.0% max.

Combined effect: 0.9% typ., 1.8% max.

Drift (1/2 to 8 hr. at 25°C): 0.2% typ., 0.5% max.

NOTE:
SEE FIGURE 4 FOR MOUNTING DIRECTION.

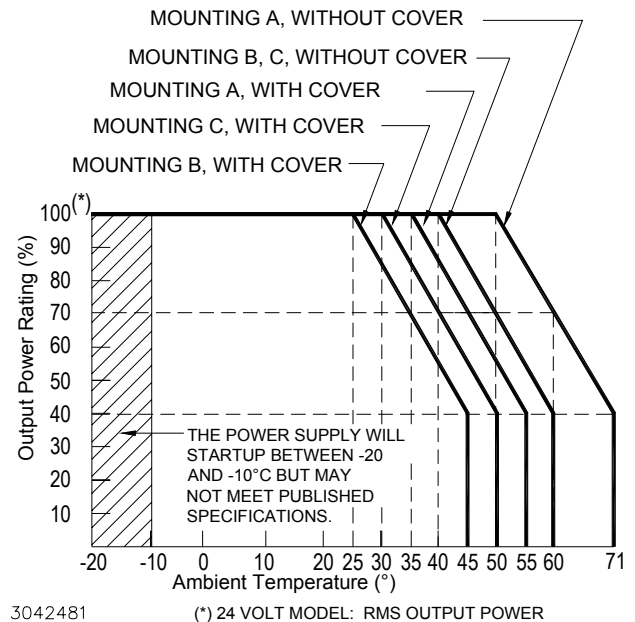

FIGURE 1. OUTPUT POWER VS. TEMPERATURE

TRANSIENT RECOVERY: A step load change from 50% to 100% of rated output current in 50 microseconds or more, produces no more than 4% output voltage excursion. Recovery time is 1ms maximum.

OUTPUT HOLDING TIME: Upon input interruption the output is maintained for:

@100V a-c:

5V to 48V Models: 40 mS typ. (20 mS min.)
3.3V Model: 30 mS typ. (20 mS min.)

@240V a-c:

5V to 48V Models: 50 mS typ. (25mS min.)
3.3V Model: 40 mS typ. (25 mS min.)

START UP TIME:

@100V a-c: 500mS max., 300mS typ.

@240V a-c: 200mS max., 100mS typ.

OVERVOLTAGE PROTECTION: Fixed, factory set. See Table 1. The overvoltage circuit is set by Zener diode clamp, latching will occur.

OVERCURRENT: Square type, output voltage returns to rated level upon removal of cause of malfunction.

OPERATING TEMPERATURE: -10 to 71°C (start up -20 to -10°C). See the derating, Figure 1. Do not allow the power supply to become dust covered because that will decrease the cooling efficiency of the unit and cause insulation to deteriorate.

STORAGE TEMPERATURE: -30°C to + 75°C.

COOLING: Natural convection.

ORIENTATION: Vertical or horizontal.

HUMIDITY: 10% to 95% RH, operating and storage, noncondensing, wet bulb temperature < or = 35°C.

DIELECTRIC STRENGTH: (at 15 to 35°C ambient, 10 to 85% relative humidity, cutout current 20 ma):

Between input and output terminals:
3.0 KV a-c for one minute.

Between input terminals and ground:
2 KV a-c for one minute.

Between output terminals and ground:
500V a-c for one minute.

INSULATION RESISTANCE: Between input and output, input and ground, output and ground: 100 megohms minimum (500V d-c, 15 to 35°C ambient, 10 to 85% relative humidity)

VIBRATION: Three axes, one hour each, sweep time 10 min., nonoperating:
5-10 Hz., 10 mm amplitude.
10-200 Hz., 2G (19.6m/s²).

SHOCK: (non-operating, one-half sinusoidal pulse, three shocks to each axis):
Acceleration: 60G (588m/s²),
Duration: 11mS ±5mS

IV — INSTALLATION

MOUNTING THE POWER SUPPLY: Refer to Figures 4 and 5. The unit may be mounted on one mounting surface. Note the restrictions for maximum penetration of mounting screws. The air surrounding the power supply must not exceed the ambient values given in the graph in Figure 1.

CONNECTIONS: Connect the load to the power supply as shown in Figure 3A, B or C. The unit is shipped with shorting links in place for Local sensing. The AC input power is applied via the terminal block. Make sure to connect the AC input Neutral, Line and Ground wires to the respective terminals of the terminal block (see Figure 2). **Sensing (either Local or Remote) MUST be used.**

EMC - EMISSIONS:

Radiated Noise 30MHz to 1GHz:
FCC Class B, VCCI-B, EN55011-B, EN55022-B

Conducted Noise 0.15MHz to 30MHz:
FCC Class B, VCCI-B, EN55011-B, EN55022-B

Input Harmonics (on AC Mains) 0 to 2kHz:
EN 61000-3-2.

EMC - IMMUNITY:

ESD: EN 61000-4-2 Level 4, Normal operation.

Radiated Field Noise:
EN 61000-4-3 Level 3, Normal operation.

Electrical Fast Transient/Burst (EFT):
EN 61000-4-4 Level 3, Normal operation.

Surge: EN 61000-4-5 Level 4, no damage.

Conducted Noise:
EN 61000-4-6 Level 3, Normal operation.

Power Frequency Magnetic Field:
EN 61000-4-8 Level 4, Normal operation.

Voltage Dips, Short Interruptions, Voltage Variation:
EN 61000-4-11, Normal operation.

SAFETY: All units designed to meet EN 60950 (U.S. UL 60950 3rd Ed.; Canada: CAN/CSA-22.2 No. 60950-00 3rd Ed. (ambient temp. 50°C). RKW 50W units are CE marked per the Low Voltage Directive (LVD), EN60950. [The standards do not apply with DC input operation.]

WEIGHT: 13.3 oz. (380 grams) max

WARRANTY: One year.

LOCAL/REMOTE SENSING: Figure 3 shows proper connection of multiple loads using either remote or local sensing. **If local or remote sensing is not configured, the unit will not work properly.** The unit is shipped with shorting links in place for Local sensing. For remote sensing, remove the shorting links and connect the +S and -S terminals to the load. Remote sensing compensation is up to 0.4V per load wire (0.15V for RKW 3.3-12K, 0.25V for RKW 5-10K). Transient recovery specs may not be met when remote sensing is used. If oscillations set off over-voltage protection, install one electrolytic capacitor (470µF min) between +S and + and one between - and -S terminals.

V — OPERATION

When output voltage is available, the green LED is on. The Output Voltage Adjust trimmer (see Figure 2) allows adjustment of the output voltage within the range specified in Table 1.

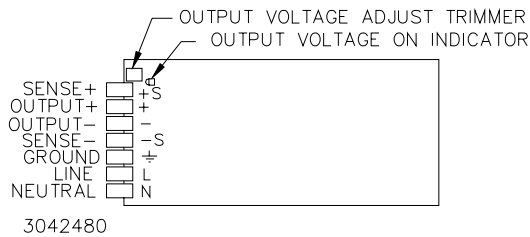

FIGURE 2. COMPONENT LOCATIONS

REMOTE VOLTAGE PROGRAMMING: In addition to the integral trimmer, output voltage can also be adjusted via an external variable resistance (see Figure

3B). The variable resistance specified in Table 1 must be substituted for the shorting link between + and +S terminals. Note that load effect for RKW 50W is increased using this technique, and may exceed values listed above under STABILIZATION.

SERIES OPERATION: When a number of power supplies are operating in series, the current rating is to be limited to the rating of the power supply with the lowest rating. A diode ($V_r > 2 \Sigma V_o$, $I_f > 2I_o$, $V_f \ll \text{low}$) must be connected to the power supply output terminals to protect the unit from reverse voltage.

PARALLEL OPERATION: Identical units may be operated in parallel for increased current capability. Use either local or remote sensing for all supplies in the parallel group.

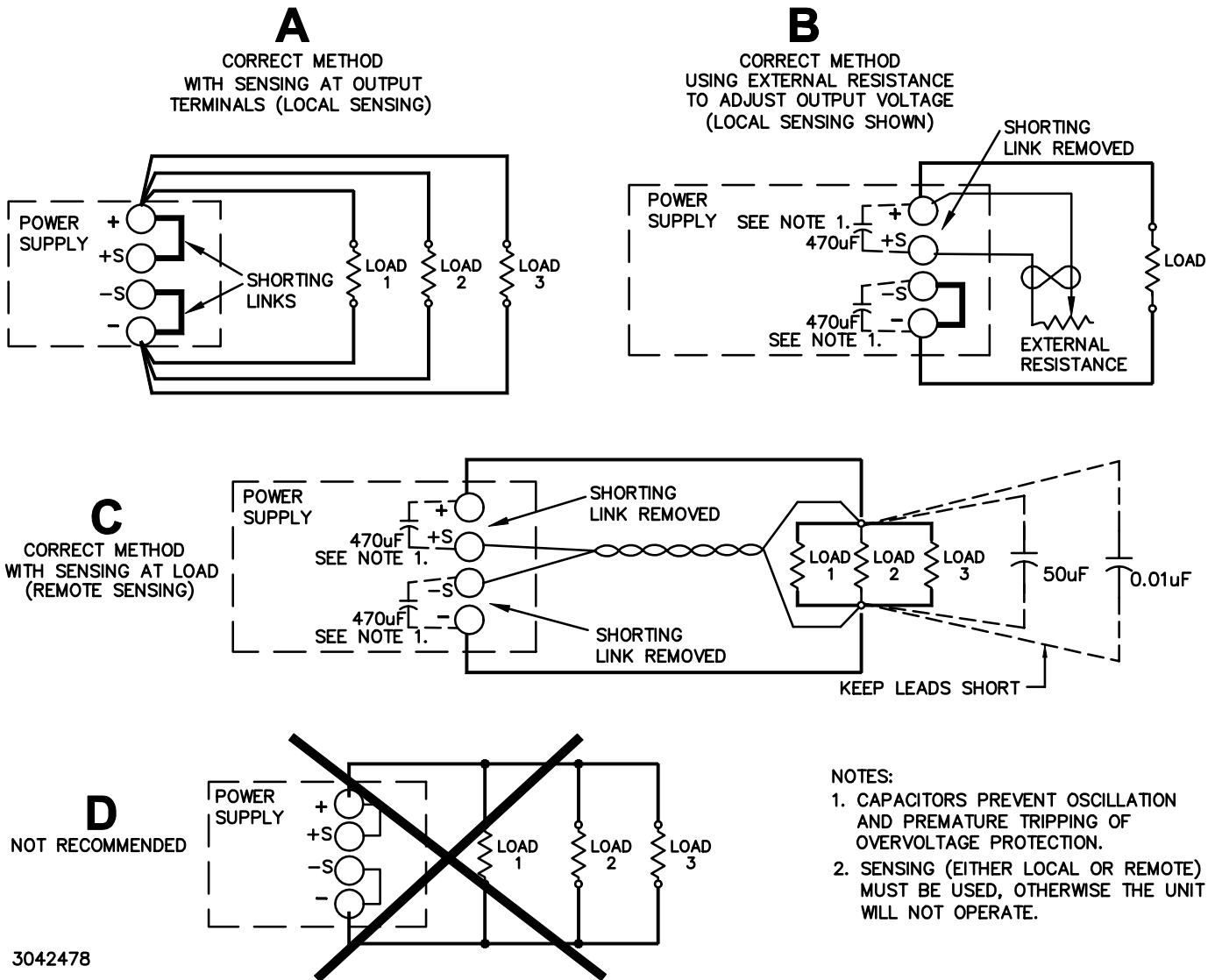
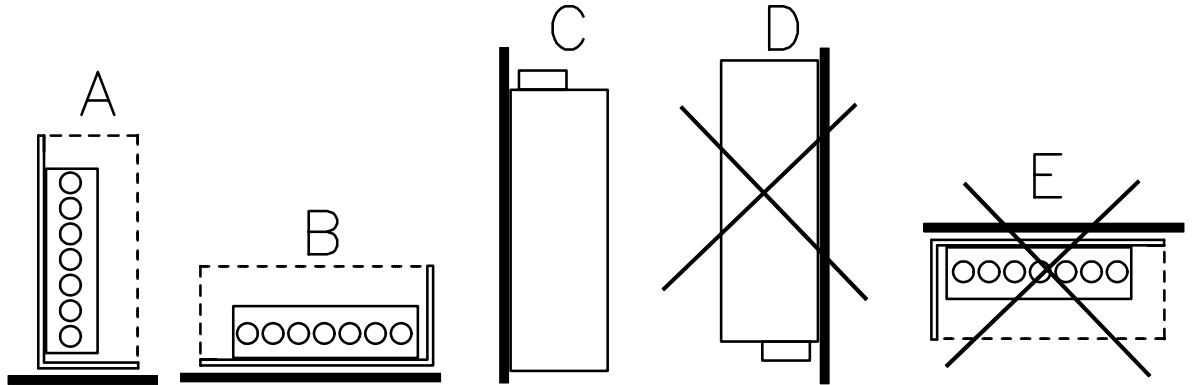

FIGURE 3. LOAD CONNECTIONS



- NOTES:
1. METHODS D AND E ARE NOT RECOMMENDED DUE TO INSUFFICIENT VENTILATION.
 2. REFER TO FIGURE 1 FOR OUTPUT POWER VS. TEMPERATURE FOR MOUNTING METHOD SELECTED.

3042479

FIGURE 4. POWER SUPPLY MOUNTING

- NOTES:
1. MAX PENETRATION OF M3 MOUNTING HOLES IS 0.24 (6) FROM CASE SURFACE.
 2. ± 0.04 (± 1) TOLERANCE UNLESS OTHERWISE SPECIFIED.
 3. DIMENSIONS ARE IN INCHES, DIMENSIONS IN BRACKETS () ARE IN MILLIMETERS.
 4. REFER TO FIGURE 4 FOR MOUNTING ORIENTATION.

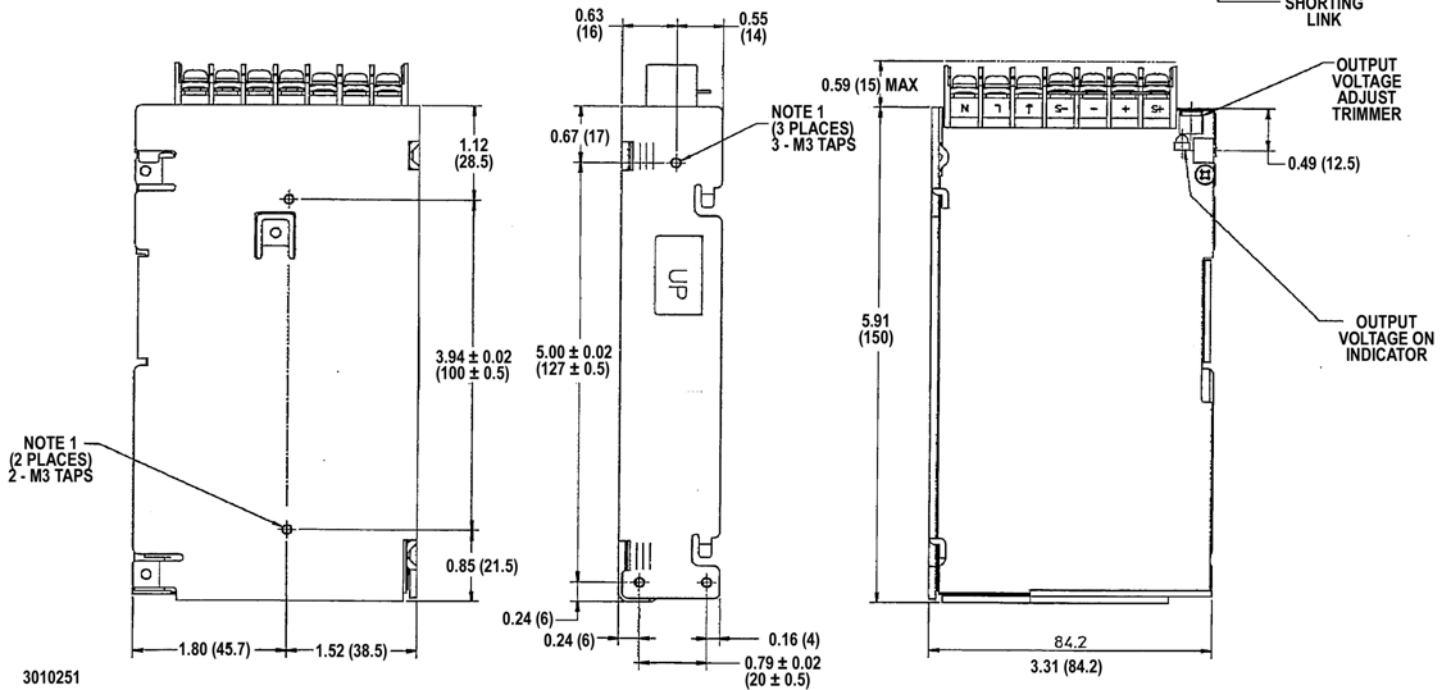
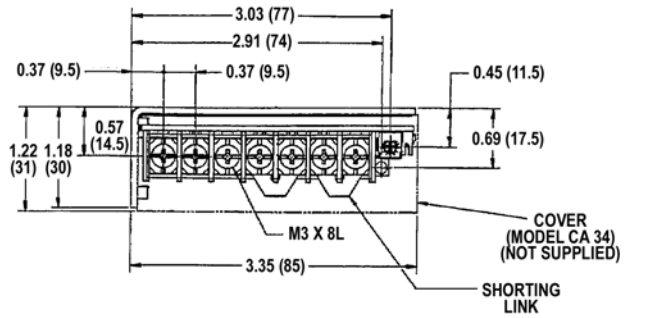

FIGURE 5. RKW 50W MECHANICAL OUTLINE DIAGRAM