

INSTRUCTION MANUAL



KEPCO An ISO 9001 Company.

**KIT
219-0407**

CA 400 MOUNTING EARS KIT

1. DESCRIPTION

This kit provides instructions and the hardware components required to install mounting ears on the CA 400 rack adapter.

2. INSTALLATION

2.1 MATERIAL SUPPLIED (See Table 1.)

TABLE 1. MATERIAL SUPPLIED

ITEM	KEPCO PART NUMBER	QUANTITY
• Ear Bracket	128-1791	2
• Handle	139-0229	2
• Ferrule	170-0001	4
• Screw (10-32 X 0.005, ST., FLPO) Attaches handle to ear brackets	101-0396	4
• Screw (6-32 X 0.187, ST., FLPO) Attaches ear brackets to CA 400 rack adapter	101-0407	8

2.2 PROCEDURE (Refer to Figure 1.)

1. Remove any MST modules from the CA 400 rack adapter.
2. Attach handle to one ear bracket using two (2) screws (P/N 101-0396) and ferrule (P/N 170-0001).
3. Position mounting ear (with handle assembled) inside the rack adapter cover at one side, aligning the four (4) threaded holes of the tab with the corresponding countersunk holes on the cover side panel; attach using four (4) flat head screws (Kepeco P/N 101-0407) provided.
4. Repeat above procedure for the other mounting ear.

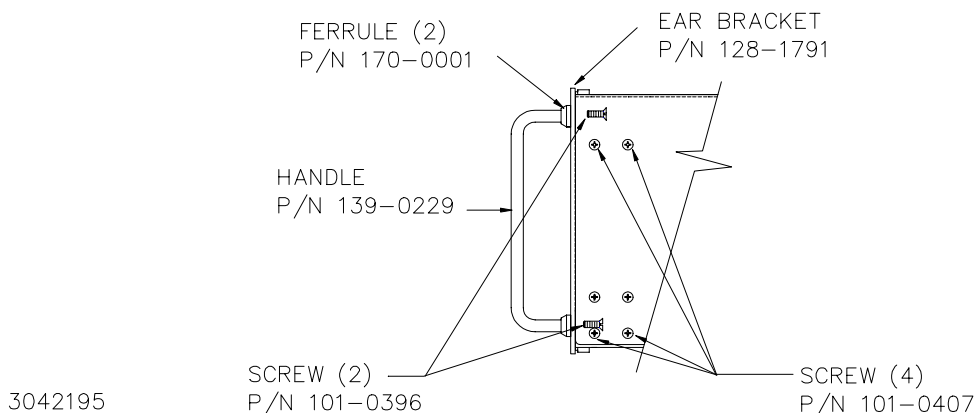

FIGURE 1. MOUNTING EAR INSTALLATION, RIGHT SIDE (TYPICAL)

KEPCO, INC. ● 131-38 SANFORD AVENUE ● FLUSHING, NY. 11352 U.S.A. ● TEL (718) 461-7000 ● FAX (718) 767-1102
<http://www.kepcopower.com> ● email: hq@kepcopower.com