

# OPERATOR MANUAL

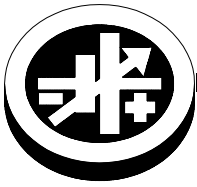

**KEPCO** An ISO 9001 Company.

**JBW**  
**10W SERIES** 

## 10 WATT SINGLE OUTPUT SWITCHING POWER SUPPLIES

### I — INTRODUCTION

**SCOPE OF MANUAL.** This instruction manual covers the installation and operation of the Kepco JBW 10W Series of RoHS (Reduction of Hazardous Substances) compliant Switching Power Supplies.

**DESCRIPTION.** The Kepco JBW 10W Series consists of five models of switching power supplies, with a single output as shown in Table 1. Units may be operated with a nominal 100 to 120V a-c and 220 to 240V a-c (input voltage range 85 to 265 Va-c), 50-60 Hz (input frequency range 47-440Hz) They will also operate on 110V to 370V d-c input. The JBW 10W Series employs a light weight ferrite core with 100 KHz switching frequency. Regulation is provided by pulse width modulation. A FET power stage, operating in the flyback mode provides a smooth isolated d-c output.

A thermistor circuit prevents excessive turn-on current surge. Overvoltage protection is provided. Current limiting with automatic recovery from short circuit is featured. Units are manufactured on an open frame pc board.

Table 1 contains specifications and operating limits of individual JBW 10W Series models. Section II (following) contains specifications and operating limits common to all JBW 10W Series Models.

### II — SPECIFICATIONS

The following specifications are at nominal input voltages and 25°C and apply to all models unless otherwise specified.

**TABLE 1. OUTPUT RATINGS AND SPECIFICATIONS, JBW 10W SERIES**

MODEL		JBW 03-2R0	JBW 05-2R0	JBW 12-0R9	JBW 15-0R7	JBW 24-0R5
OUTPUT VOLTS, d-c		3.3V	5V	12V	15V	24V
SETTING TOLERANCE		3.14-3.46V	4.75-5.25V	11.4-12.6V	14.25-15.75V	22.8-25.2V
ADJUSTMENT RANGE		2.7-3.6V	FIXED	FIXED	FIXED	FIXED
MAXIMUM OUTPUT RATINGS	50° C amb.	2.0A/6.6W (3)	2.0A/10W	0.9A/10.8W	0.7A/10.5W	0.5A/12W
	60° C amb.	1.4A/4.6W	1.4A/7.0W	0.63A/7.56W	0.49A/7.35W	0.35A/8.4W
CURRENT LIMIT (AMPS)		3.0 min	2.5 min	1.12 min	0.87 min	0.62 min
OVP RANGE (VOLTS)		4.0 min	5.75 min	13.8 min	17.25 min	27.6 min
EFFICIENCY	100 Va-c	68%	71%	78%	79%	82%
	240 Va-c	68%	71%	79%	80%	83%
ACCEPTABLE OUTPUT CAPACITOR μFmax., (fixed load resistance)		10000	10000	5000	4000	2000
RIPPLE AND NOISE <sup>(1)</sup> (mV p-p)	ripple (typ)	80	80	120	120	120
	ripple -10-0°C, max	140	140	160	160	160
	spike noise (max) <sup>(1)</sup>	120	120	150	150	150
	spike noise -10-0°C, max <sup>(1)</sup>	160	160	180	180	180

(1) Switching component approximately 100KHz, 0 to 100% load, 0 to 50 °C, tested with 100μF electrolytic and 0.1μF film capacitors across the measuring points and connected to the power supply via 5.9 in (150mm) wires; oscilloscope bandwidth ≤ 20MHz.

### INPUT CHARACTERISTICS:

**INPUT VOLTAGE:** (0 to 100% load, -10 to 60°C)  
Nominal 100-240V a-c, 220-240V a-c  
Range: 85-265V a-c

### INPUT SOURCE FREQUENCY:

Nominal: 50/60 Hz;  
Range: 47-440 Hz

**INPUT CURRENT:** (100% load at 25°C with nominal output voltage):

100V a-c input: 0.25 typ., 0.35 max.  
240V a-c input: 0.15 typ., 0.25 max.

**INPUT PROTECTION AND SOFT START:** A thermistor circuit reduces start-up surge. Units are protected against shorts by an input fuse. Fuse value 2.0A, 250V.

**INPUT SURGE:** Cold start:

100V a-c input, 100% load: 15A typ, 20A max.  
240V a-c input, 100% load: 30A typ., 40A max.

**LEAKAGE CURRENT:** Cold start:

100V a-c and 60 Hz (single pole switching):  
0.75mA max, 0.1mA typ  
240V a-c and 60 Hz (single pole switching in conformance to UL 1950/IEC 950):  
0.75mA max, 0.15mA typ

**POWER FACTOR:** Meets EN 61000-3-2, Class D

100V a-c: 0.6 typ.  
240V a-c: 0.45 typ.

**OUTPUT CHARACTERISTICS:**

**SOURCE EFFECT:** (85 to 265 Va-c)  
0.4% max.

**LOAD EFFECT:** measured at sensing terminals  
(0% - 100% load change)  
0.8% max.

**TEMPERATURE EFFECT:** (-10 to 50°C)  
1.0% max.

**TIME EFFECT OR DRIFT:** (1/2 to 8 hr. at 25°C)  
0.4% max.

**TRANSIENT RECOVERY:** A step load change from 50% to 100% of rated load in 50 microseconds or more produces no more than 4% output voltage excursion. Temperature range from -10 to 50°C.

**HOLD UP TIME:** Condition: 100% output load. Upon input interruption the output is maintained for:

100 Va-c: 15mS typ. (JBW 03-2R0: 20mS typ.)  
240 Va-c: 140mS typ. (JBW 03-2R0: 190mS typ.)

**START UP TIME:**

700mS max. 200mS typ. at 100 Va-c, 240 Va-c

**OVERVOLTAGE PROTECTION:** Fixed, factory set. See Table 1. The overvoltage circuit is set by Zener diode clamp, latching could occur.

**OVERCURRENT:** Square type, output voltage returns to rated level upon removal of cause of malfunction (long term overcurrent could damage unit).

**ENVIRONMENTAL CHARACTERISTICS**

**OPERATING TEMPERATURE:** -10 to 60°C (start up -20 to -10°C). See the derating, Figure 1.

**STORAGE TEMPERATURE:** -30°C to + 75°C.

**COOLING:** Natural convection. Do not allow the power supply to become dust covered because that will decrease the cooling efficiency of the unit and cause insulation to deteriorate.

**ORIENTATION:** Vertical or horizontal (see Figure 2).

**HUMIDITY:** 20% to 90% relative humidity, operating and storage, noncondensing, wet bulb temperature < or = 35°C.

**VIBRATION:** Three axes, one hour each, sweep time 10 min., nonoperating.

5-10 Hz., 10 mm amplitude  
10-200 Hz., 2G (19.6m/s<sup>2</sup>) acceleration

**SHOCK:** Three axes, 60G (588m/s<sup>2</sup>), 11 mS ±5mSec pulse duration, three shocks each axis, nonoperating, 1/2 sine pulse.

**GENERAL CHARACTERISTICS**

**WITHSTANDING VOLTAGE:** (at 5 to 35°C ambient, 45 to 85% relative humidity, cutout current 10 mA):

Between input and output terminals:

3.0 KV a-c for 1 minute.

Between input and chassis:

2000V a-c for 1 minute.

Between output terminals and chassis:

500V a-c for 1 minute.

**INSULATION RESISTANCE:** Between input and output, input and chassis, output and chassis: 100 megohms minimum (500V d-c, 5 to 35°C ambient, 45 to 85% relative humidity)

**SAFETY:** All units designed to meet UL 1950D3, CSA Electrical Bulletin 22.2NO950-95, and TÜV Rheinland EN60950 (ambient temp. 50°C). JBW 10W units are CE marked per the Low Voltage Directive (LVD), EN60950. [The standards do not apply with DC input operation]

**EMI CONDUCTED:** FCC Class B, VCCI-B, EN55011-B, EN55022-B.

**ESD:** Ground potential area to chassis: 10KV (charge capacitor 500pF, series resistor 100 Ohms).

**SURGE WITHSTAND:** 1.2x50µs 3KV pulse, input to input, input to chassis (operating, 100 Ohm internal series resistor).

**INCOMING NOISE:** 1 µs, 2 KV pulse, 50-60Hz, with 50 ohm termination, input to input, input to ground, less than five minutes, operating, normal operation.

**WARRANTY:** One year.

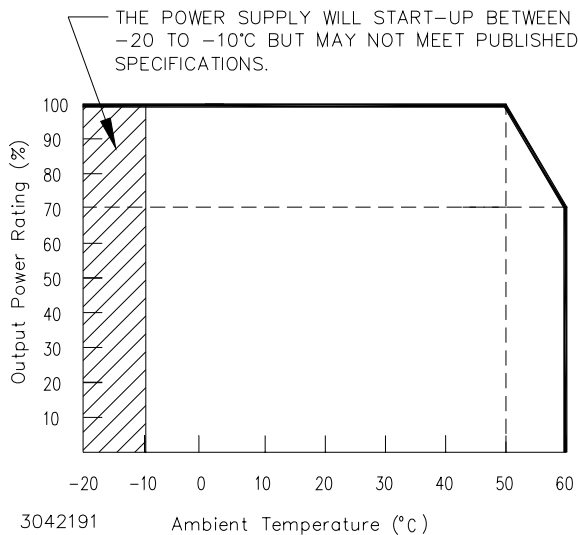

FIGURE 1. OUTPUT POWER VS. TEMPERATURE

### III — INSTALLATION

**MOUNTING POWER SUPPLY.** Refer to Figures 2 and 4. The unit may be mounted on one mounting surface. The air surrounding the power supply must not exceed the ambient values given in the graph in Figure 1.

**INSULATION.** Install unit 0.3 inches (8mm) away from base with the use of 0.24 inch (6mm) diameter spacers attached to the PC board. Keep at least 0.16 inches (4mm) spacing around and above the unit to comply with insulation and safety requirements. An insulator must be used if the spacing is less than 0.16 inches (4mm) (see Figure 2).

**VENTILATION.** It is recommended to keep at least 0.40 inches (10mm) clearance from adjacent equipment for proper ventilation.

**CONNECTIONS.** Connect the load to the power supply by connecting the two (+) output wires from terminal block TB2 to the load (+) terminal, and the two (-) output wires from TB2 to the load (-) terminal. The AC input power is applied via the terminal block TB1. Make sure to connect the AC input Neutral and Line wires to the P2 and P3 pins respectively of TB1 (see Figure 3). A Cable Kit (P/N 219-0406) is available as an option from Kepco (see Figures 3 and 5). The kit includes an input cable, terminated on one end with an input mating connector; and an output cable, terminated on one end with an output mating connector.

### IV — OPERATION

**PROTECTION DIODE:** When a number of power supplies are operating in series, the current rating is to be limited to the rating of the power supply with the lowest rating. A diode ( $V_r > 2 \sum V_o$ ,  $I_f > 2 I_o$ ,  $V_f \ll \text{low}$ ) must be connected to the power supply output terminals to protect the unit from reverse voltage.

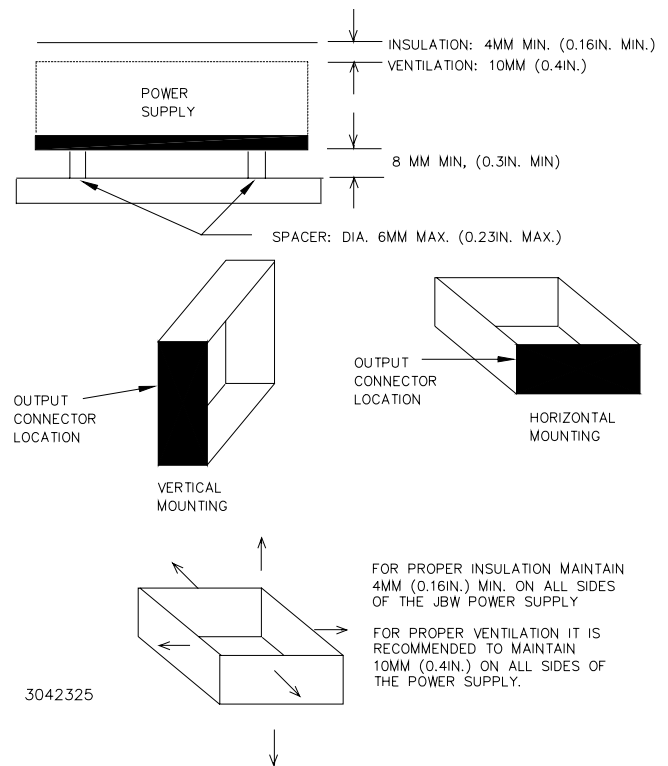

FIGURE 2. VENTILATION, INSULATION AND MOUNTING DIRECTION

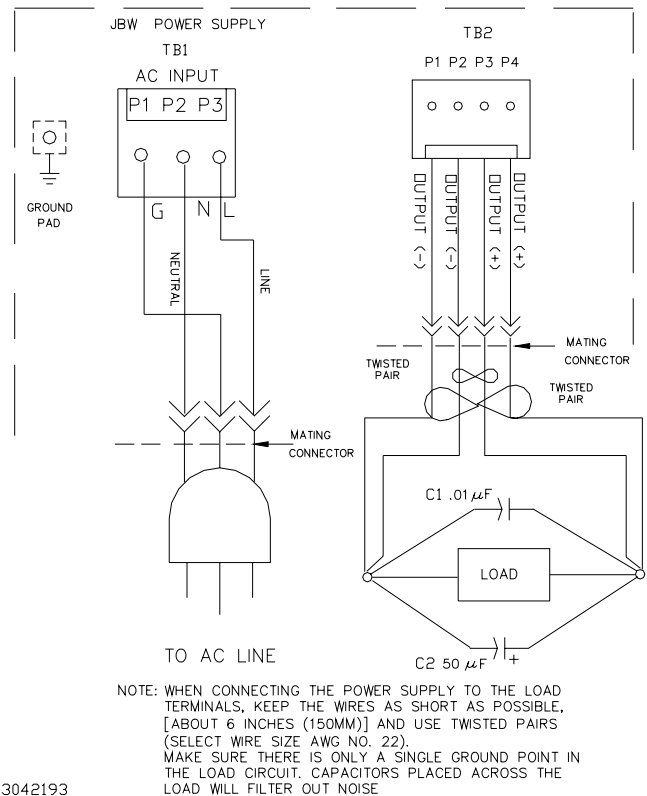
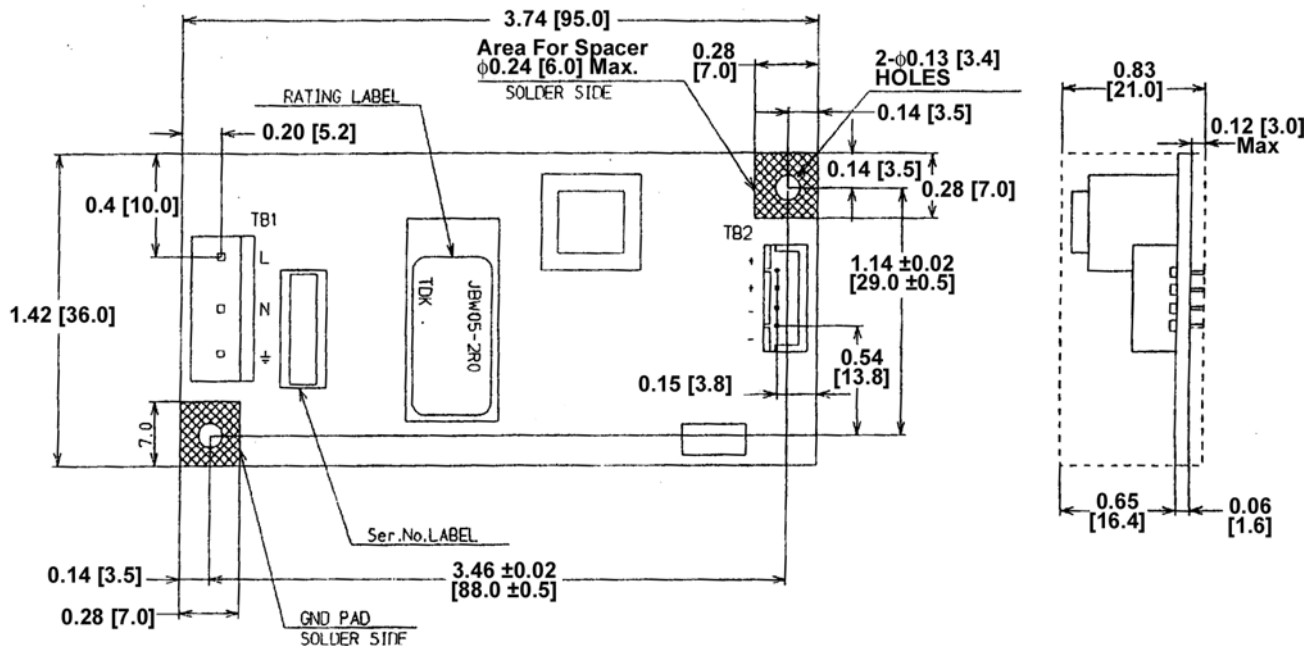

FIGURE 3. LOAD CONNECTIONS



TB1

P3	L
P2	N
P1	⊕

INPUT CONNECTOR

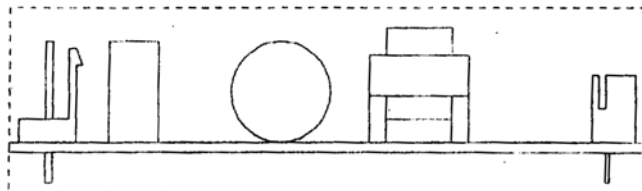

TB2

P4	+
P3	
P2	-
P1	

OUTPUT CONNECTOR

3010234

- NOTES:
1. Dimensions are in inches, dimensions in brackets are in millimeters.
  2. TOLERANCES:  $\pm 0.04"$  [ $\pm 1.0$  mm] unless specified.
  3. WEIGHT: 1.76 oz. (50 gr.) max.
  4. PCB: Thickness =  $0.06 \pm 0.008$  in. ( $1.6 \pm 0.2$ mm)

FIGURE 4. JBW 10W MECHANICAL OUTLINE DIAGRAM

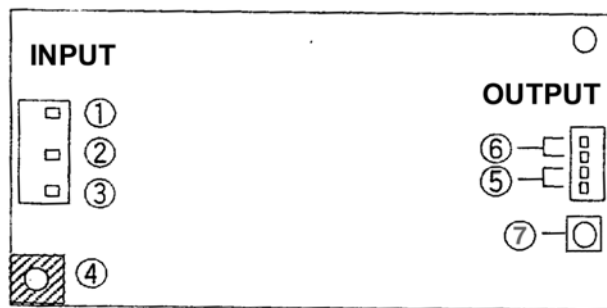

3042327

Terminal	Function
1	Input L
2	Input N
3	Ground
4	Ground Pad
5	Output (-)
6	Output (+)
7	Output ADJ (JBW 03-2R0 only)

Mating Connectors <sup>(4)</sup>			
Connector	Terminal Pin	Socket Housing	MFR
Input	SVH-21T-P1.1	VHR-5N	JST <sup>(1)</sup>
	T101	H101-05	LCE <sup>(2)</sup>
	50539-8100	51144-0500	MLX <sup>(3)</sup>
Output	SXH-001T-P0.6	XHP-4	JST <sup>(1)</sup>
	T221-01	H221-04	LCE <sup>(2)</sup>
	67262-001	67261-0400	MLX <sup>(3)</sup>

- (1) JST= Japan Solderless Terminal Mfg. Co.
- (2) LCE= Long Chu Electronics Co.
- (3) MLX = Molex
- (4) Optional cable kit (P/N 219-0406) includes one input and one output cable (one meter long) with mating connectors for TB1 and TB2, unterminated at other end.

FIGURE 5. INPUT/OUTPUT CONNECTIONS