

# INSTRUCTION MANUAL



**KEPCO** An ISO 9001 Company.

**KIT  
DIN MRW -150S  
-160S, -170S**

## DIN-RAIL MOUNTING KIT

### MRW 150/151KV, 160/161KV, 170/171KV

**DESCRIPTION.** Kepco KITS, Models DIN MRW-150S, -160S, and -170S each contain a cover, cable kit, left and right mounting clips, and associated hardware (see Table 1) used to install MRW Series power supplies on a DIN rail. The -150S suffix is for MRW 150KV and 151KV Models, -160S is for MRW 160KV and 161KV models and -170S is for MRW 170KV and 171KV models. The S" suffix is for mounting along the short dimension (width) as shown in Figure 1. Outline dimensions are shown in Figure 4.

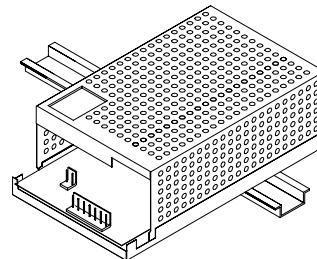

3042064

**FIGURE 1. S SUFFIX ORIENTATION**

**INSTALL COVER.** Attach the cover to the power supply per Instruction Manual supplied with the cover.

**INSTALL CLIPS.** Attach left and right clips to power supply using hardware supplied (see Figure 3).

**INSTALL CABLE KIT.** Attach wires to the power supply per Instruction Sheet supplied with cable kit.

**INSTALL POWER SUPPLY ON DIN RAIL.** To mount the power supply on the rail insert one end of both clips under one edge of the rail, then snap the other end of the two clips into place (see Figure 2A).

**REMOVING POWER SUPPLY FROM DIN RAIL.** While grasping the power supply with one hand, use a screwdriver to apply leverage towards the left as shown in Figure 2B to disengage each clip from the rail. Where mounting clips are close together, it may be necessary to apply leverage with two screwdrivers simultaneously.

#### A - INSTALLATION

#### B - REMOVAL

3042065

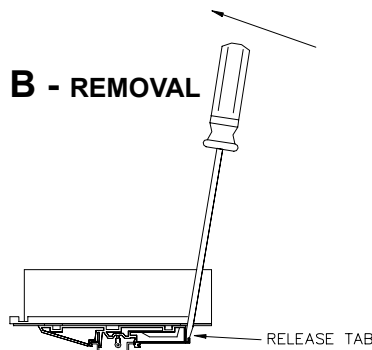
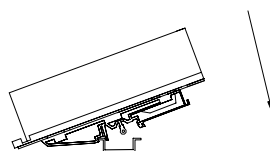

**FIGURE 2. INSTALLATION AND REMOVAL OF POWER SUPPLY FROM DIN RAIL**

**TABLE 1. COMPONENTS SUPPLIED**

KIT MODEL NO.	COVER PART NO.	CABLE KIT PART NO.	CLIP (QTY 2) PART NO.	BRACKET (QTY 2) PART NO.	SCREW (QTY 4) PART NO.	WASHER (QTY4) PART NO.
DIN MRW-150S	CA 19	KIT 219-0184	108-0362	128-2004	101-0383 (8-32 X 0.187 PPH)	103-0017 (NO. 8, INT. TOOTH)
DIN MRW-160S	CA 20	KIT 219-0184	108-0362	128-2004	101-0383 (8-32 X 0.187 PPH)	103-0017 (NO. 8, INT. TOOTH)
DIN MRW-170S	CA 20	KIT 219-0239	108-0362	128-2004	101-0383 (8-32 X 0.187 PPH)	103-0017 (NO. 8, INT. TOOTH)

NOTE: Clip and Bracket are supplied preassembled into left and right mounting clip assemblies. To replace a mounting clip assembly, order both the clip and bracket and assemble per Figure 3 detail.

KEPCO, INC. | 131-38 SANFORD AVENUE | FLUSHING, NY. 11352 U.S.A. | TEL (718) 461-7000 | FAX (718) 767-1102  
http://www.kepcopower.com | email: hq@kepcopower.com

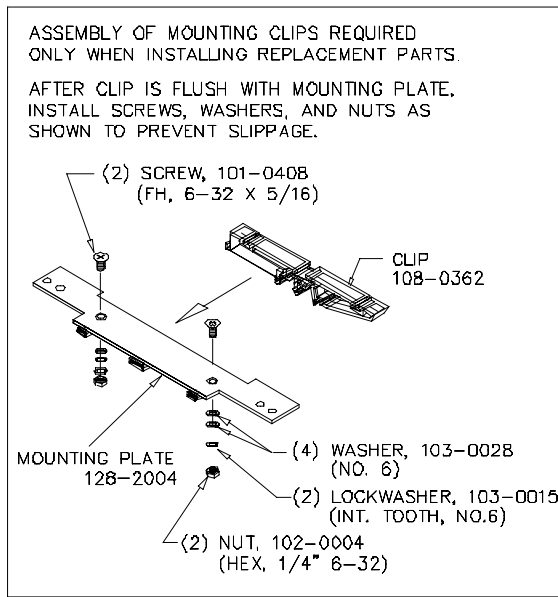

3042066

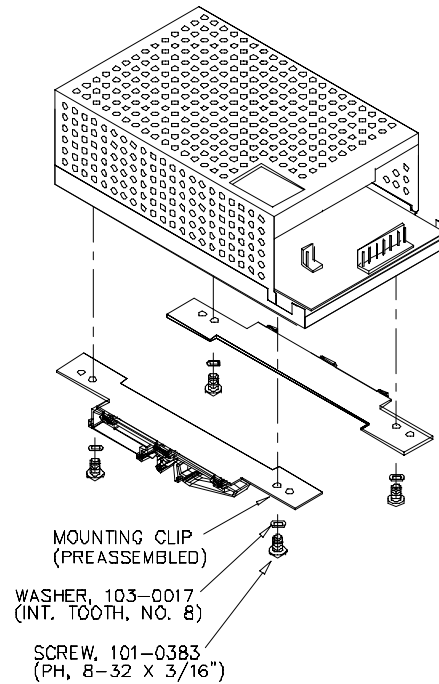

**FIGURE 3. INSTALLATION OF KIT ON MRW POWER SUPPLY**

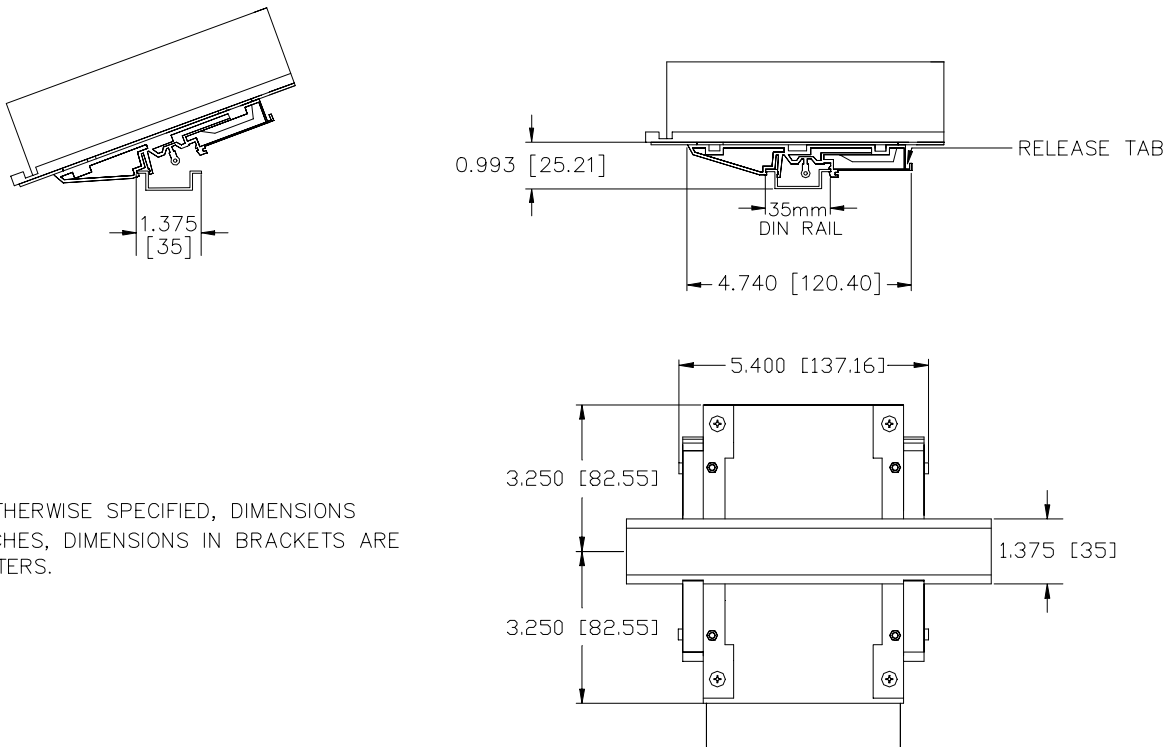

NOTE:  
 UNLESS OTHERWISE SPECIFIED, DIMENSIONS  
 ARE IN INCHES, DIMENSIONS IN BRACKETS ARE  
 IN MILLIMETERS.

3042067

**FIGURE 4. MRW POWER SUPPLY WITH KIT INSTALLED, OUTLINE DIMENSIONS**