

INSTRUCTION MANUAL



KEPCO An ISO 9001 Company.

**KIT
DIN ERD
-60P**

DIN-RAIL MOUNTING KIT FOR SERIES ERD 60W

DESCRIPTION. Kepeco KIT, Models DIN ERD-60P contains a mounting bracket with left and right preassembled mounting clips and associated hardware used to install ERD Series power supplies on a DIN rail. The -60 suffix is for the 60 Watt Series; the "P" suffix is for mounting the power supply perpendicular to the DIN rail as shown in Figure 1. Outline Dimensions are shown in Figure 5

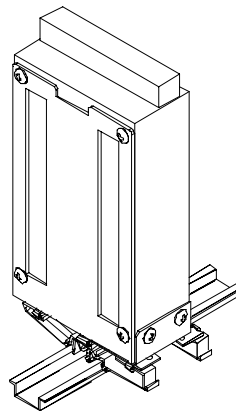

3042034

FIGURE 1. P SUFFIX ORIENTATION

TABLE 1. COMPONENTS SUPPLIED

KIT MODEL NO.	MOUNTING BRACKET PART NO.	SCREW (QTY 6) (Power Supply To Mounting Bracket) PART NO.	WASHER (QTY 6) (Power Supply To Mounting Bracket) PART NO.	CLIP (QTY 2) PART NO.	CLIP PLATE (QTY 2) PART NO.	SCREW Thread-form (QTY 4) (Clip To Mounting Bracket) PART NO.	WASHER (QTY 4) (Clip To Mounting Bracket) PART NO.
DIN ERD-60P	128-2013	101-0383 (8-32 X 3/16 BHPH)	103-0017 (NO. 8, INT. TOOTH)	108-0362	128-1938	101-0443 (4-40 X 1/4 BHPH)	103-0014 (NO. 4, INT. TOOTH)

INSTALLATION

1. **INSTALL COVER.** Attach the cover to the power supply per instruction manual supplied with the cover.
2. **INSTALL MOUNTING BRACKET.** Attach the mounting bracket to the power supply using the hardware supplied (see Figure 2).

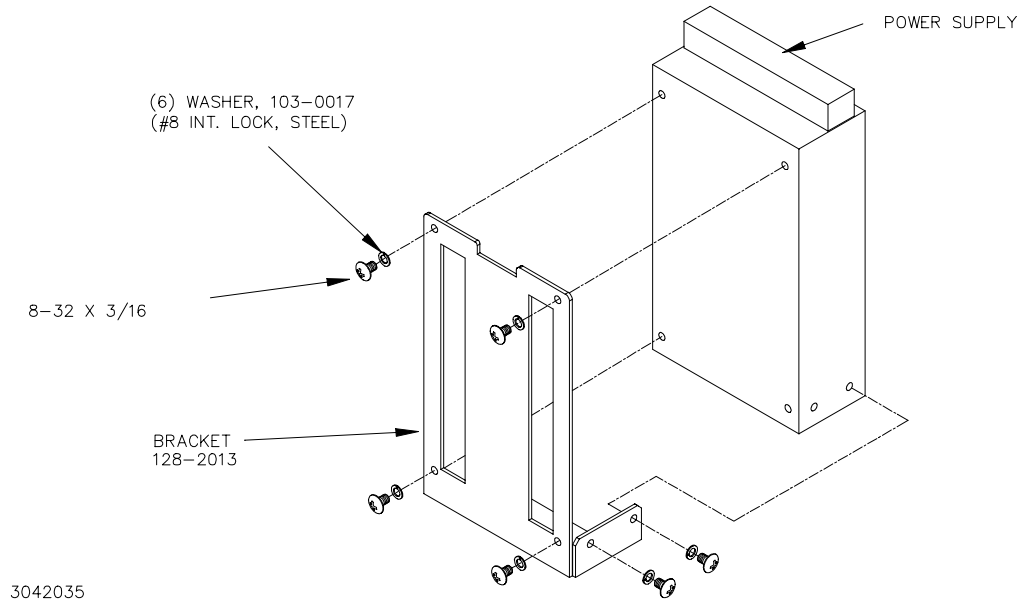

FIGURE 2. INSTALLING MOUNTING BRACKET ON POWER SUPPLY

3. **INSTALL CLIPS.** Attach preassembled mounting clips into the mounting bracket holes using hardware supplied (see Figure 3).

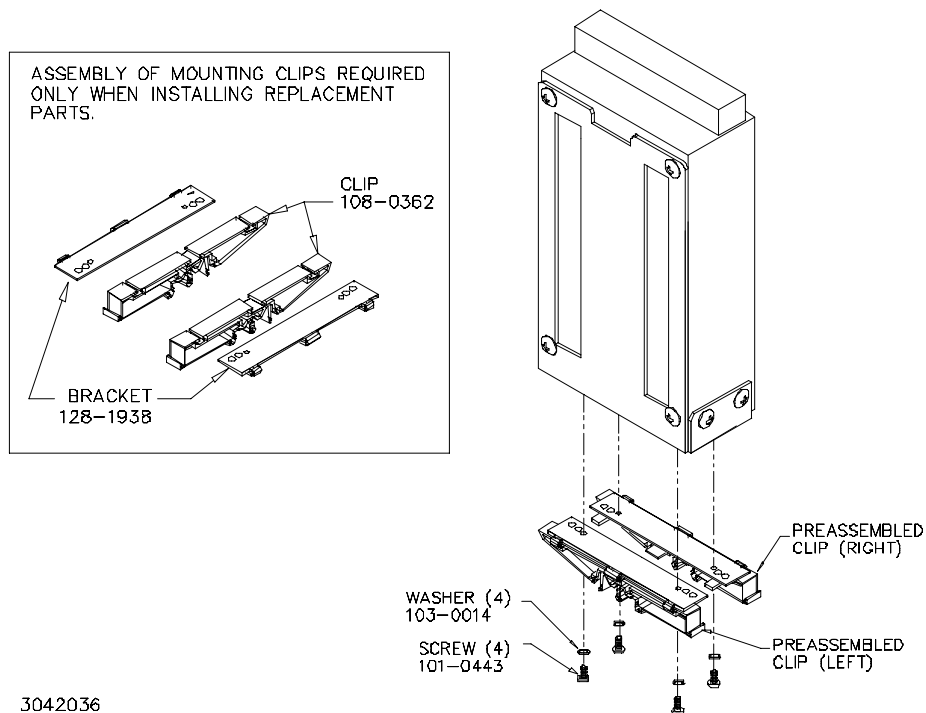
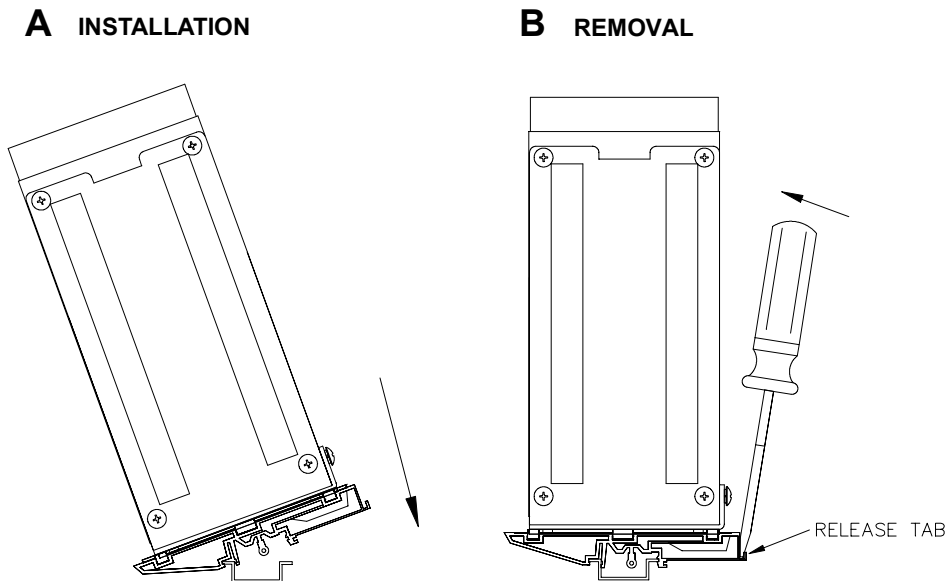

FIGURE 3. INSTALLING CLIPS ON MOUNTING BRACKET

4. **INSTALL POWER SUPPLY ON DIN RAIL.** To mount the power supply on the rail insert one end of both mounting clips under one edge of the rail, then snap the other end of the two clips into place (see Figure 4A).



3042037

FIGURE 4. INSTALLATION AND REMOVAL OF POWER SUPPLY FROM DIN RAIL

REMOVING POWER SUPPLY FROM DIN RAIL. While grasping the power supply with one hand, Insert a screwdriver into the access holes provided and apply leverage towards the left as shown in Figure 4B to disengage each clip from the rail. Where mounting clips are close together, it may be necessary to apply leverage with two screwdrivers simultaneously.

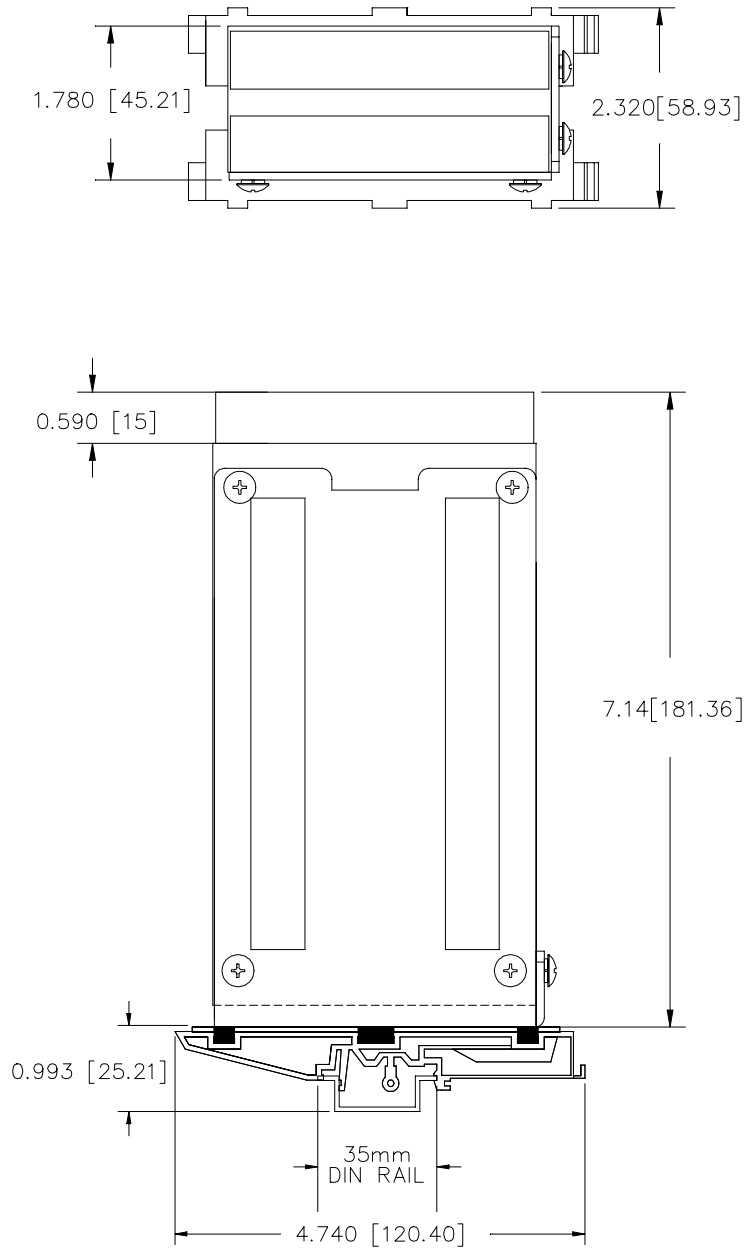

NOTE:

UNLESS OTHERWISE SPECIFIED: DIMENSIONS ARE IN INCHES,
DIMENSIONS IN BRACKETS ARE IN MILLIMETERS.

3042038

FIGURE 5. ERD 30W POWER SUPPLY WITH KIT INSTALLED, OUTLINE DIMENSIONS