

INSTRUCTION MANUAL



KEPCO An ISO 9001 Company.

KIT
DIN RAX-300S
DIN RCW-350S

DIN-RAIL MOUNTING KIT FOR SERIES RAX 300W, RCW 350W

DESCRIPTION. Kepco KITS, Models DIN RAX-300S and DIN RCW-350S, each contain two preassembled mounting clips and associated hardware used to install RAX 300 Watt and RCW 350 Watt Series power supplies on a DIN rail. The "S" suffix is for mounting along the short dimension (width) as shown in Figure 1. Outline dimensions are shown in Figure 4.

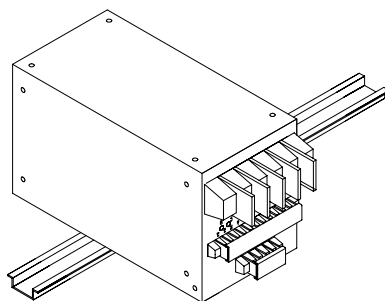

3041816

FIGURE 1. S SUFFIX ORIENTATION

INSTALLING KIT. Attach the preassembled mounting clips to the power supply using the hardware supplied (see Figure 3). The clips may be mounted with the release lever on either side to facilitate removal.

INSTALLING POWER SUPPLY ON DIN RAIL. To mount the power supply on the rail insert one end of both clips under one edge of the rail, then snap the other end of the two clips into place (see Figure 2A).

REMOVING POWER SUPPLY FROM DIN RAIL. While grasping the power supply with one hand, use a screwdriver to apply leverage towards the left as shown in Figure 2B to disengage each clip from the rail. Where mounting clips are close together, it may be necessary to apply leverage with two screwdrivers simultaneously.

A - INSTALLATION

B - REMOVAL

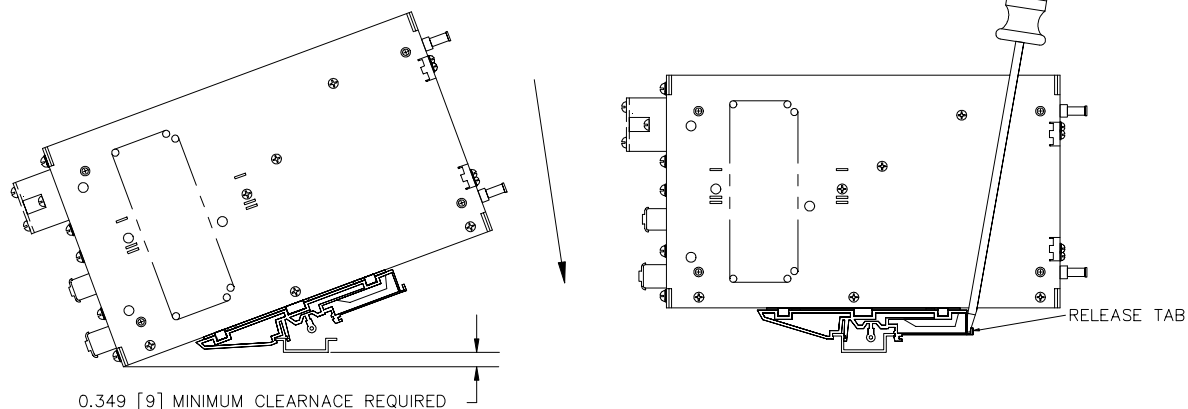

3041817

0.349 [9] MINIMUM CLEARANCE REQUIRED

FIGURE 2. INSTALLATION AND REMOVAL OF POWER SUPPLY FROM DIN RAIL

KEPCO, INC. ● 131-38 SANFORD AVENUE ● FLUSHING, NY. 11352 U.S.A. ● TEL (718) 461-7000 ● FAX (718) 767-1102
<http://www.kepcopower.com> ● email: hq@kepcopower.com

ASSEMBLY OF MOUNTING CLIPS REQUIRED ONLY WHEN INSTALLING REPLACEMENT PARTS.
 AFTER CLIP IS FLUSH WITH MOUNTING PLATE, INSTALL SCREWS, WASHERS, AND NUTS AS SHOWN TO PREVENT SLIPPAGE.

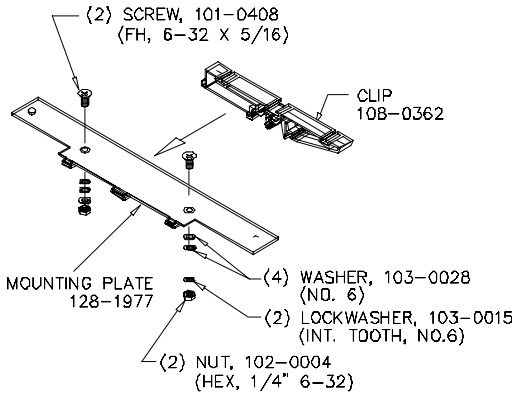

3041820

	RCW 350W SERIES	RAX 300W SERIES
LOCKWASHER	SUPPLIED WITH UNIT	103-0017 INT. TOOTH, NO. 8
SCREW	SUPPLIED WITH UNIT	101-0383 PH, 8-32 X 3/16"

3041818

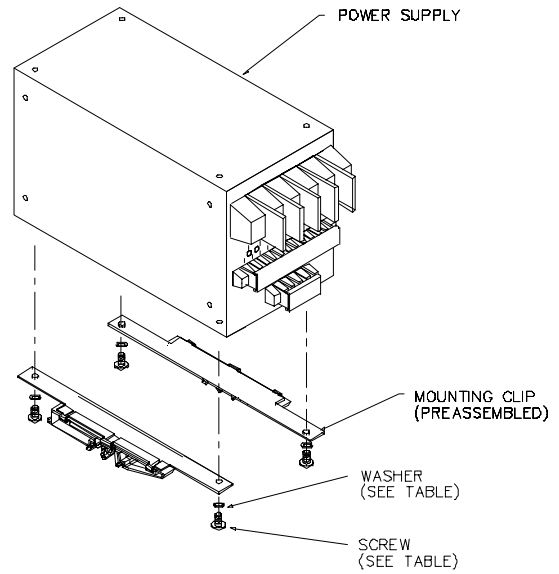
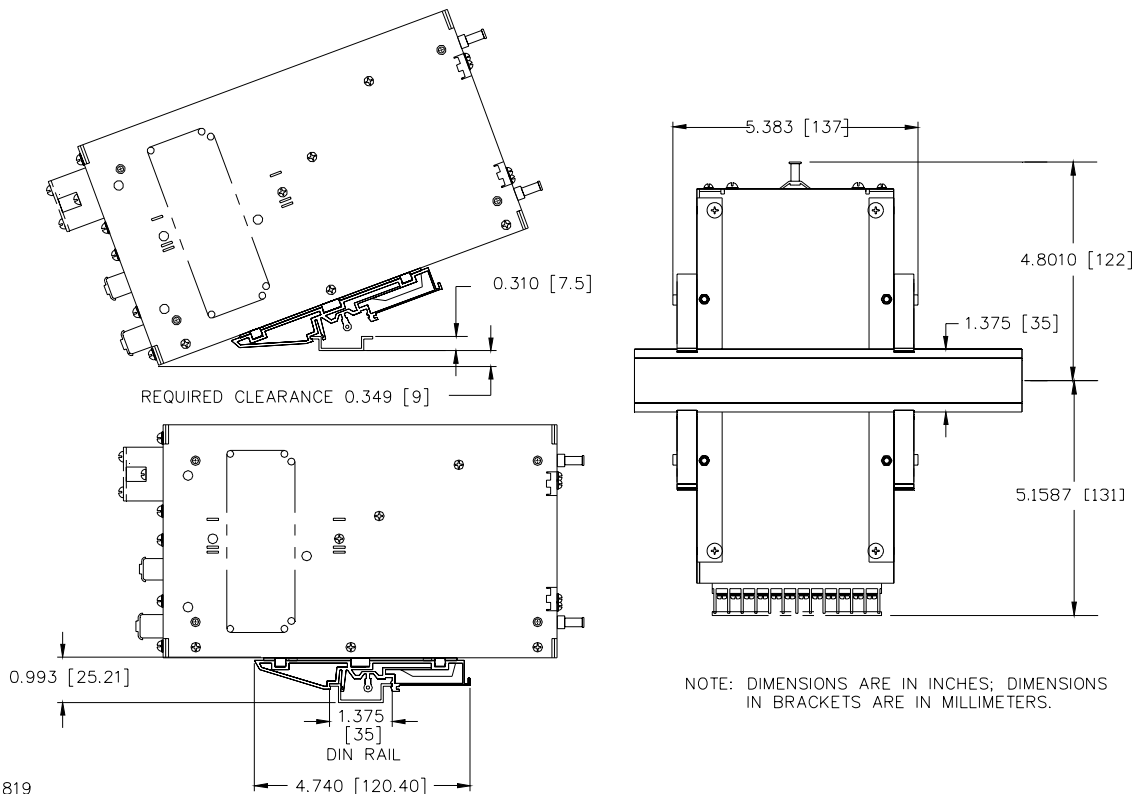

FIGURE 3. INSTALLATION OF KIT ON RAX 175W POWER SUPPLY



3041819

FIGURE 4. RAX 175W POWER SUPPLY WITH KIT INSTALLED, OUTLINE DIMENSIONS