

# INSTRUCTION MANUAL



**KEPCO** An ISO 9001 Company.

**KIT  
DIN FAW  
-15P, -25P**

## DIN-RAIL MOUNTING KIT FOR SERIES FAW 15W, 25W

**DESCRIPTION.** Kepco KITS, Models DIN FAW-15P and -25P each contain a cover, a mounting bracket with left and right preassembled mounting clips and associated hardware used to install FAW Series power supplies on a DIN rail. The -15 suffix is for the 15 Watt Series and -25 for the 25 Watt Series. The "P" suffix is for mounting the power supply perpendicular to the DIN rail as shown in Figure 1. Outline Dimensions are shown in Figure 5

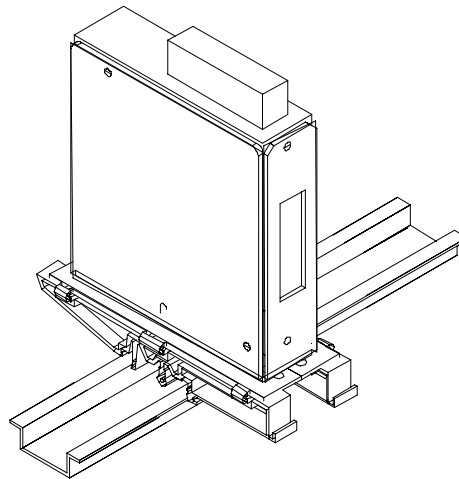

3041699

**FIGURE 1. P SUFFIX ORIENTATION**

**TABLE 1. COMPONENTS SUPPLIED**

KIT MODEL NO.	COVER PART NO.	MOUNTING BRACKET PART NO.	SCREW (QTY 4) (Power Supply To Mounting Bracket) PART NO.	WASHER (QTY 4) (Power Supply To Mounting Bracket) PART NO.	CLIP (QTY 2) PART NO.	CLIP PLATE (QTY 2) PART NO.	SCREW Thread-form (QTY 4) (Clip To Mounting Bracket) PART NO.	WASHER (QTY 4) (Clip To Mounting Bracket) PART NO.
DIN FAW-15P	CA 24	128-1949	101-0092 (4-40 X 5/16 BHPH)	103-0014 (NO. 4, INT. TOOTH)	108-0362	128-1938	101-0443 (4-40 X 1/4 BHPH)	103-0014 (NO. 4, INT. TOOTH)
DIN FAW-25P	CA 25	128-1950	101-0092 (4-40 X 5/16 BHPH)	103-0014 (NO. 4, INT. TOOTH)	108-0362	128-1938	101-0443 (4-40 X 1/4 BHPH)	103-0014 (NO. 4, INT. TOOTH)

KEPCO, INC. ● 131-38 SANFORD AVENUE ● FLUSHING, NY. 11352 U.S.A. ● TEL (718) 461-7000 ● FAX (718) 767-1102

<http://www.kepcopower.com> ● email: [hq@kepcopower.com](mailto:hq@kepcopower.com)

## INSTALLATION

1. **INSTALL COVER.** Attach the cover to the power supply per instruction manual supplied with the cover.
2. **INSTALL MOUNTING BRACKET.** Attach the mounting bracket to the power supply using the hardware supplied (see Figure 2).

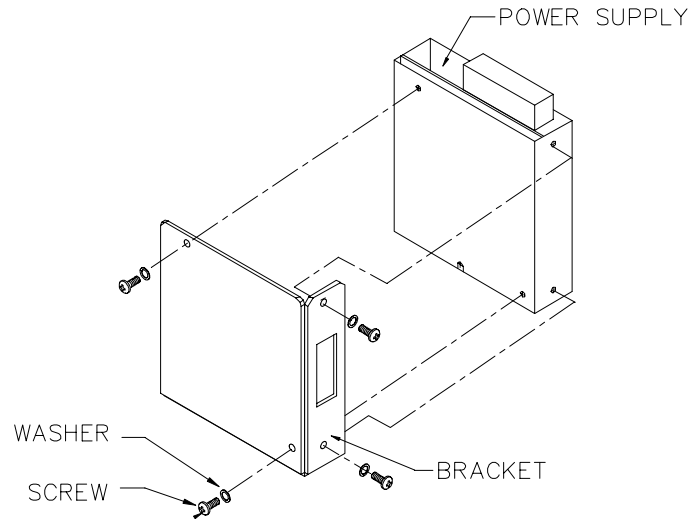

3041700

**FIGURE 2. INSTALLING MOUNTING BRACKET ON POWER SUPPLY**

3. **INSTALL CLIPS.** Attach preassembled mounting clips into the mounting bracket holes using hardware supplied (see Figure 3).

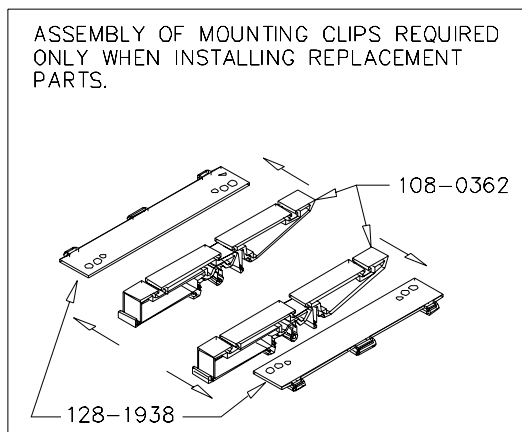

3041698

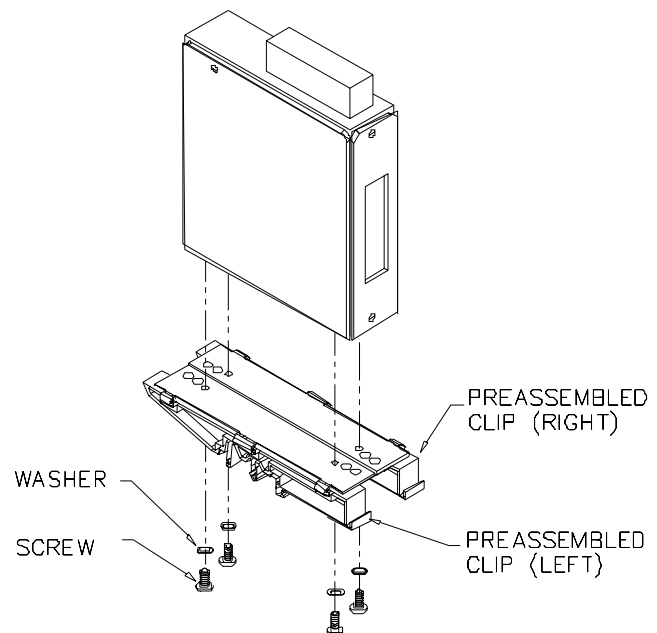

3041701

**FIGURE 3. INSTALLING CLIPS ON MOUNTING BRACKET**

4. **INSTALL POWER SUPPLY ON DIN RAIL.** To mount the power supply on the rail insert one end of both mounting clips under one edge of the rail, then snap the other end of the two clips into place (see Figure 4A).

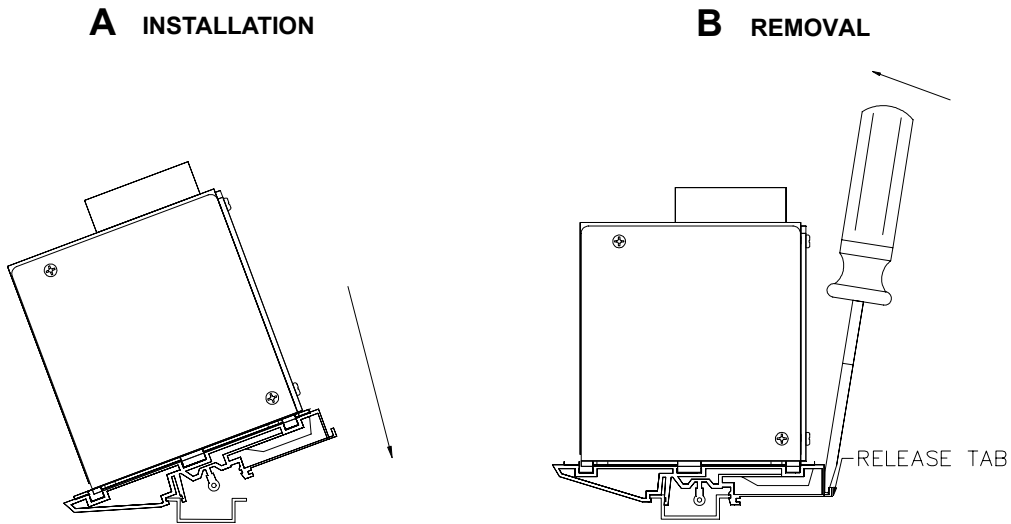

3041702

**FIGURE 4. INSTALLATION AND REMOVAL OF POWER SUPPLY FROM DIN RAIL**

**REMOVING POWER SUPPLY FROM DIN RAIL.** While grasping the power supply with one hand, Insert a screwdriver into the access holes provided and apply leverage towards the left as shown in Figure 4B to disengage each clip from the rail. Where mounting clips are close together, it may be necessary to apply leverage with two screwdrivers simultaneously.

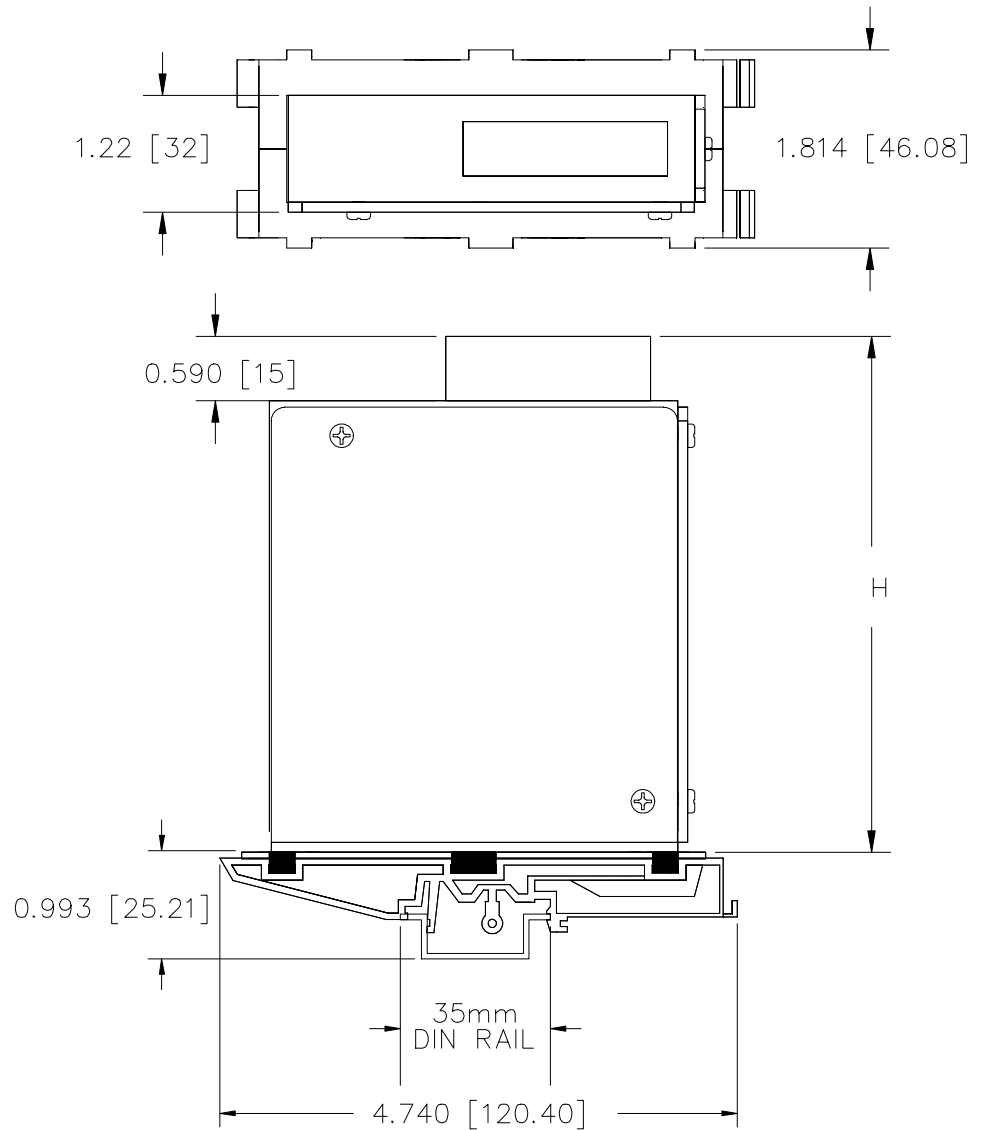

MODEL	H
DIN FAW-15P	4.88 in 124 mm
DIN FAW-25P	5.86 in 149 mm

NOTE:

UNLESS OTHERWISE SPECIFIED: DIMENSIONS ARE IN INCHES,  
DIMENSIONS IN BRACKETS ARE IN MILLIMETERS.

3041703

**FIGURE 5. FAW 15W/25W POWER SUPPLY WITH KIT INSTALLED, OUTLINE DIMENSIONS**