

INSTRUCTION MANUAL



KEPCO An ISO 9001 Company.

KIT
DIN RAX-300L,
DIN RCW-350L

DIN-RAIL MOUNTING KIT FOR SERIES RAX 300W AND RCW 350W

DESCRIPTION. Kepco Kits, Model DIN RAX-300L and RCW-350L, each contain two preassembled mounting clips and associated hardware used to install RAX 300 Watt and RCW 350 Watt Series power supplies on a DIN rail. The "L" suffix is for mounting along the long dimension (length) as shown in Figure 1. Outline dimensions are shown in Figures 4 and 5.

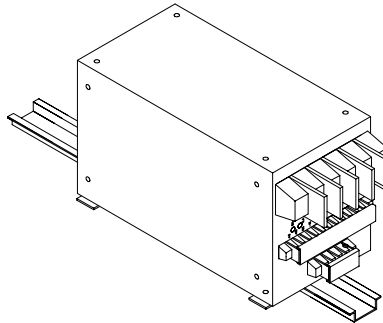

3041762

FIGURE 1. L SUFFIX ORIENTATION

INSTALLING KIT. Attach the preassembled mounting clips to the power supply using the hardware supplied (see Figure 3). The clips may be mounted with the release lever on either side to facilitate removal.

INSTALLING POWER SUPPLY ON DIN RAIL. To mount the power supply on the rail insert one end of both clips under one edge of the rail, then snap the other end of the two clips into place (see Figure 2A).

REMOVING POWER SUPPLY FROM DIN RAIL. While grasping the power supply with one hand, use a screwdriver to apply leverage towards the left as shown in Figure 2B to disengage each clip from the rail. Where mounting clips are close together, it may be necessary to apply leverage with two screwdrivers simultaneously.

A - INSTALLATION

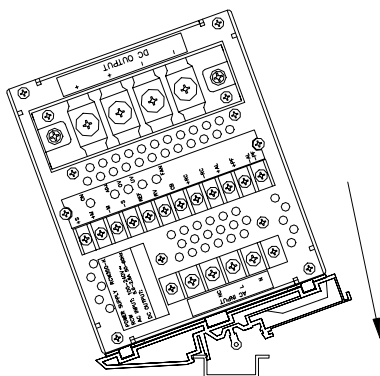

3041763

B - REMOVAL

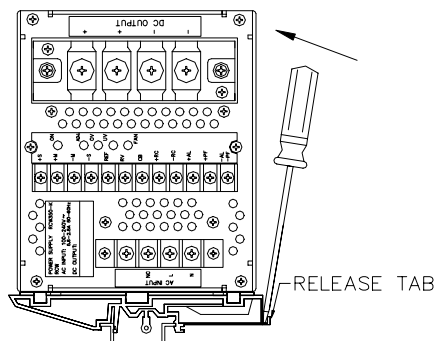
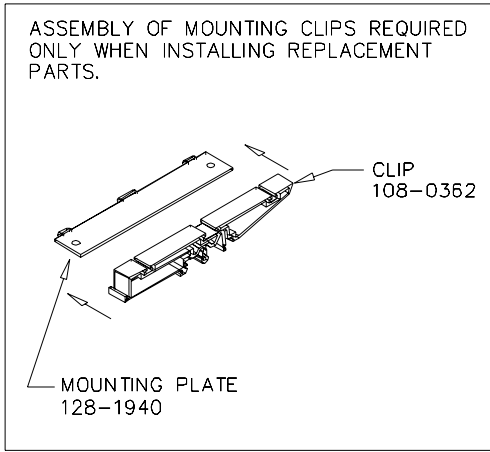

FIGURE 2. INSTALLATION AND REMOVAL OF POWER SUPPLY FROM DIN RAIL

KEPCO, INC. ● 131-38 SANFORD AVENUE ● FLUSHING, NY. 11352 U.S.A. ● TEL (718) 461-7000 ● FAX (718) 767-1102
<http://www.kepcopower.com> ● email: hq@kepcopower.com



3041764

	RCW 350W SERIES	RAX 300W SERIES
LOCKWASHER	SUPPLIED WITH UNIT	103-0017 INT. TOOTH NO.8
SCREW	SUPPLIED WITH UNIT	101-0383 PH. 8-32 X 3/16"

3041767

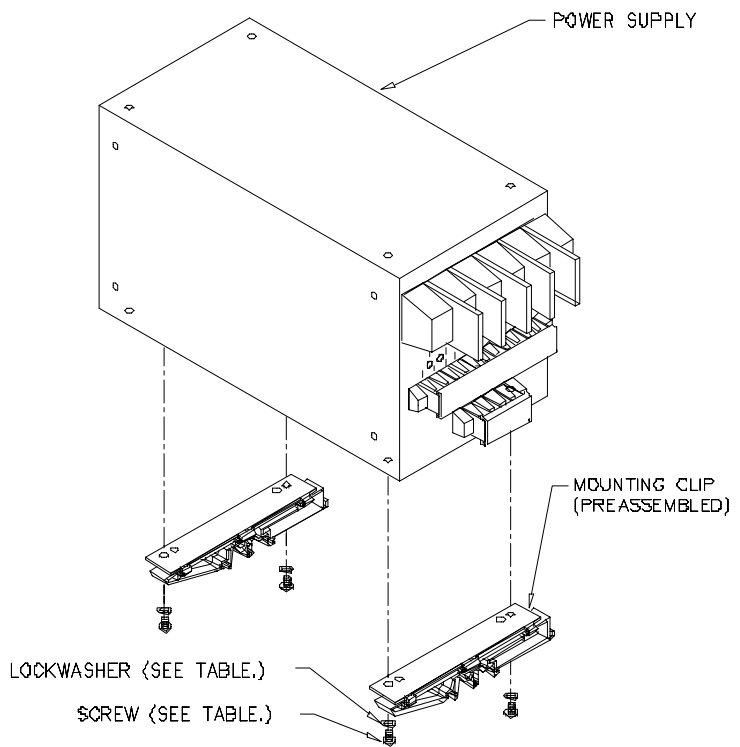
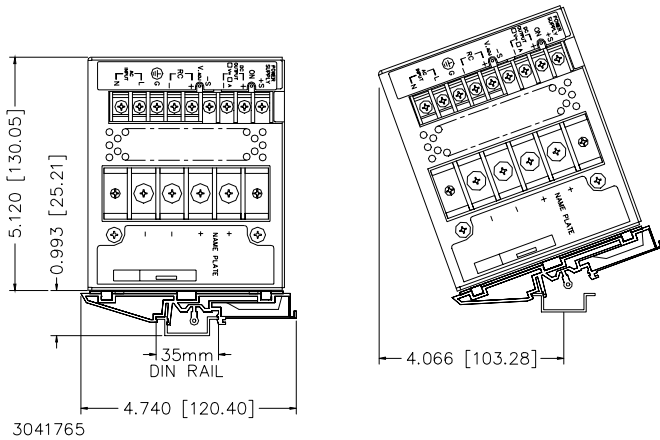
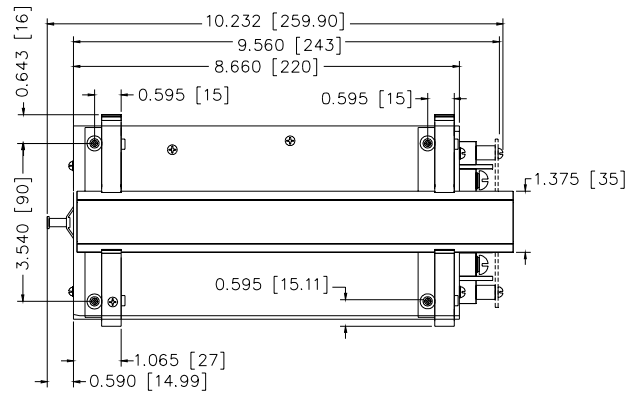
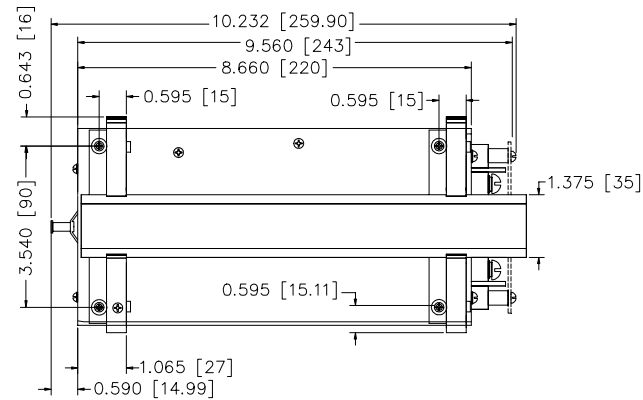
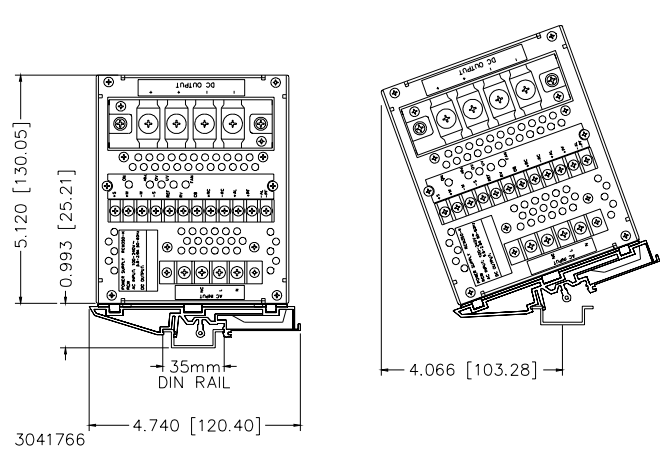

FIGURE 3. INSTALLATION OF KIT ON RAX 300W OR RCW 350W POWER SUPPLY



3041765



3041766

FIGURE 4. RAX 300W POWER SUPPLY WITH KIT INSTALLED, OUTLINE DIMENSIONS

FIGURE 5. RCW 350W POWER SUPPLY WITH KIT INSTALLED, OUTLINE DIMENSIONS