

INSTRUCTION MANUAL



KEPCO An ISO 9001 Company.

**KIT
DIN FMP/FCP
-3L, -10L,**

DIN-RAIL MOUNTING KIT FOR SERIES FMP/FCP 3W, 10W

DESCRIPTION. Kepco KITS, Models DIN FMP/FCP-3L, and -10L each contain a mounting plate with two mounting clips and associated hardware used to install FMP and FCP Series power supplies on a DIN rail. The -3 suffix is for the 3 Watt Series, and -10 for the 10 Watt Series. The "L" suffix is for mounting the power supply along the long dimension (length) as shown in Figure 1.

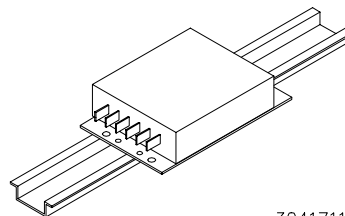

3041711

FIGURE 1. L SUFFIX ORIENTATION

TABLE 1. COMPONENTS SUPPLIED

KIT MODEL NO.	MOUNTING PLATE PART NO.	CLIP (QTY 2) PART NO.	SCREW (QTY 2) PART NO.	WASHER (QTY 2) PART NO.
DIN FMP/FCP-3L	189-0712	108-0365	101-0092 (4-40 X 0.312 BHPH)	103-0014 (NO. 4, INT. TOOTH)
DIN FMP/FCP-10L	189-0710	108-0365	101-0092 (4-40 X 0.312 BHPH)	103-0014 (NO. 4, INT. TOOTH)

INSTALLATION

- INSTALL MOUNTING PLATE.** Attach the mounting plate to the power supply using the hardware supplied (see Figure 2).
- INSTALL CLIPS.** Snap the two clips into the mounting plate holes (see Figure 3).
- INSTALL POWER SUPPLY ON DIN RAIL.** To mount the power supply on the rail insert one end of both mounting clips under one edge of the rail, then snap the other end of the two clips into place (see Figure 4A).

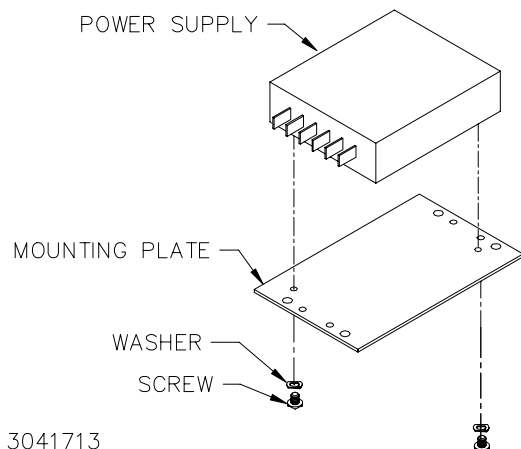

3041713

FIGURE 2. INSTALLING MOUNTING PLATE ON POWER SUPPLY

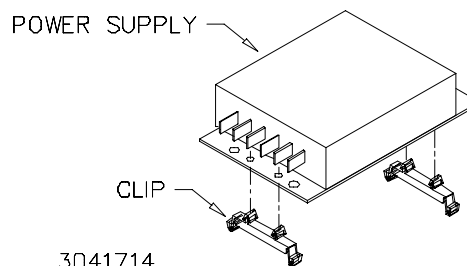

3041714

FIGURE 3. INSTALLING CLIPS ON MOUNTING PLATE

KEPCO, INC. ● 131-38 SANFORD AVENUE ● FLUSHING, NY. 11352 U.S.A. ● TEL (718) 461-7000 ● FAX (718) 767-1102
<http://www.kepcopower.com> ● email: hq@kepcopower.com

REMOVING POWER SUPPLY FROM DIN RAIL. While grasping the power supply with one hand, Insert a screwdriver into the access holes provided and apply leverage towards the left as shown in Figure 4B to disengage each clip from the rail. Where mounting clips are close together, it may be necessary to apply leverage with two screwdrivers simultaneously.

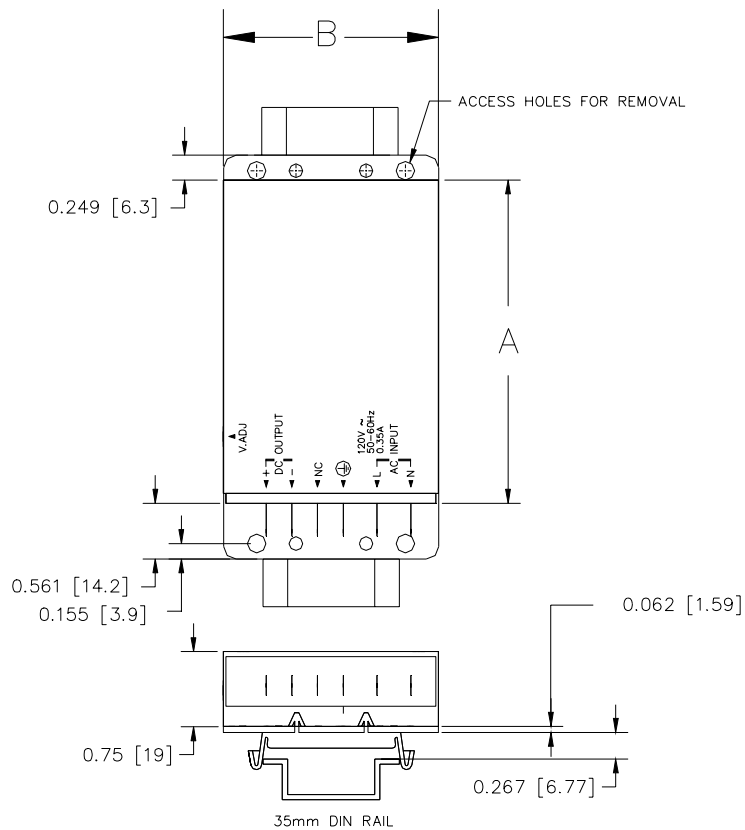
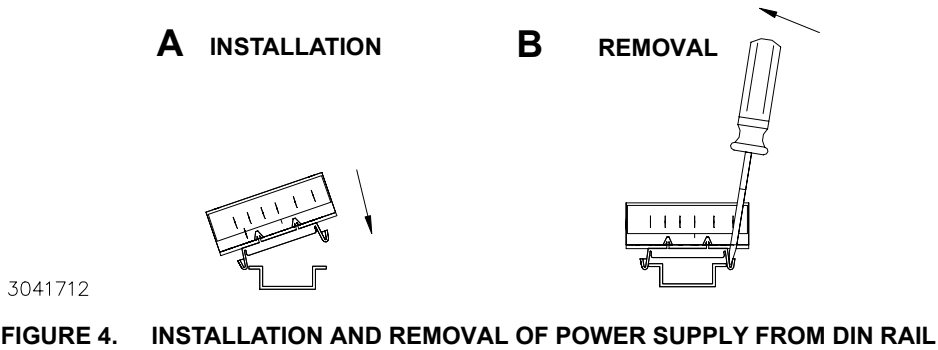

MODEL	A	B
DIN FMP/FCP -3L	1.97 in 50 mm	2.17 in 55 mm
DIN FMP/FCP -10L	3.15 in 80 mm	2.17 in 55 mm

NOTE:
UNLESS OTHERWISE SPECIFIED, DIMENSIONS ARE IN INCHES, DIMENSIONS IN BRACKETS ARE IN MILLIMETERS.

3041715

FIGURE 5. OUTLINE DRAWING