

INSTRUCTION MANUAL



KEPCO An ISO 9001 Company.

**KIT
DIN MRW-150L,
-160L, -170L**

DIN-RAIL MOUNTING KIT FOR SERIES MRW 150/151KV, 160/161KV, 170/171KV

DESCRIPTION. Kepco KITS, Models DIN MRW-150L, -160L, and -170L each contain a cover, cable kit, left and right mounting clips, and associated hardware (see Table 1) used to install MRW Series power supplies on a DIN rail. The -150L suffix is for MRW 150KV and 151KV Models, -160L is for MRW 160KV and 161KV models and -170L is for MRW 170KV and 171KV models. The “L” suffix is for mounting along the long dimension (length) as shown in Figure 1.

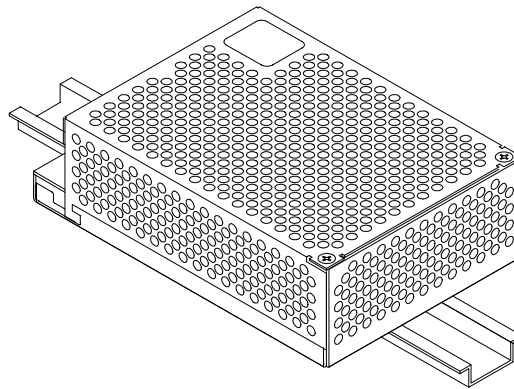

3041679A

FIGURE 1. L SUFFIX ORIENTATION

TABLE 1. COMPONENTS SUPPLIED

KIT MODEL NO.	COVER PART NO.	CABLE KIT PART NO.	CLIP (QTY 2) PART NO.	BRACKET (QTY 2) PART NO.	SCREW (QTY 4) PART NO.	WASHER (QTY4) PART NO.
DIN MRW-150L	CA 19	219-0184	108-0362	128-1938	101-0383 (8-32 X 0.187 PHPH)	103-0032 (NO. 8, SPLIT, LOCK)
DIN MRW-160L	CA 20	219-0184	108-0362	128-1938	101-0383 (8-32 X 0.187 PHPH)	103-0032 (NO. 8, SPLIT, LOCK)
DIN MRW-170L	CA 20	219-0239	108-0362	128-1938	101-0383 (8-32 X 0.187 PHPH)	103-0032 (NO. 8, SPLIT, LOCK)

NOTE: Clip and Bracket are supplied preassembled into left and right mounting clip assemblies. To replace a mounting clip assembly, order both the clip and bracket and assemble per Figure 2 detail.

INSTALLATION

1. **INSTALL COVER.** Attach the cover to the power supply per Instruction Manual supplied with the cover.
2. **INSTALL CLIPS.** Attach left and right clips to power supply using hardware supplied (see Figure 2).

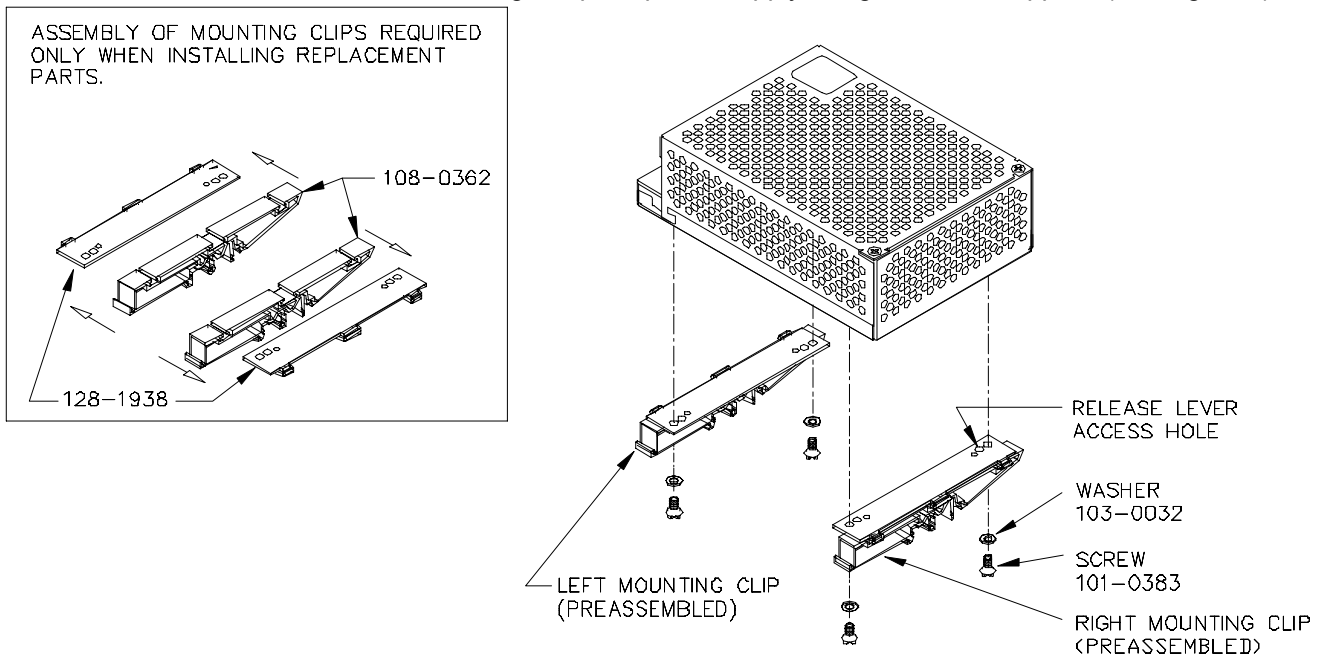

3041679B

FIGURE 2. INSTALLING CLIPS ON POWER SUPPLY

3. **INSTALL CABLE KIT.** Attach wires to the power supply per Instruction Sheet supplied with cable kit.
4. **INSTALL POWER SUPPLY ON DIN RAIL.** To mount the power supply on the rail insert one end of both clips under one edge of the rail, then snap the other end of the two clips into place (see Figure 3A).

REMOVING POWER SUPPLY FROM DIN RAIL. With power off, disconnect wires from power supply. While grasping the power supply with one hand, insert a screwdriver in the area shown in Figure 3B and apply leverage towards the left as shown in Figure 3B to disengage each clip from the rail. Where mounting clips are close together, it may be necessary to apply leverage with two screwdrivers simultaneously.

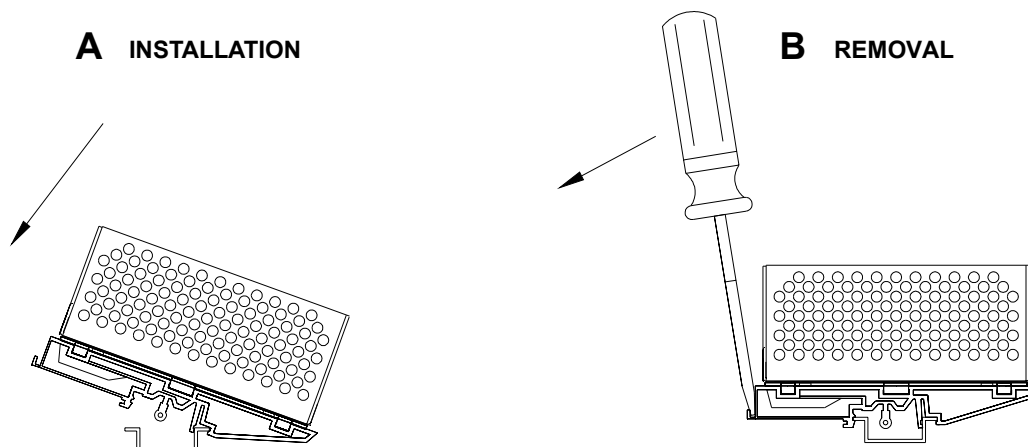

3041679C

FIGURE 3. INSTALLATION AND REMOVAL OF POWER SUPPLY FROM DIN RAIL