

INSTRUCTION MANUAL



KEPCO An ISO 9001 Company.

CA-21

COVER

ENCLOSURES AND HARDWARE SYSTEMS

DESCRIPTION. The Kepco Model CA-21 Cover is supplied for use with the Kepco FAK 15 Watt series of switching power supplies. The easily installed finished steel one-piece cover is a separate option designed for shielding and protection. The cover is attached with one screw from the FAK PCB Mounting.

INSTALLATION.

- 1) Remove PCB Mounting screw marked (A) and set aside.
- 2) Attach Cover: Engage tabs marked (B) under printed circuit board, lay cover down on printed circuit board making sure mounting hole in cover aligns with PCB mounting hole and that tab marked (C) is fully inserted into slot marked (D). It may be necessary to apply slight pressure on opposite side of cover to hold tab in slot.
- 3) Mount with screw marked (A).

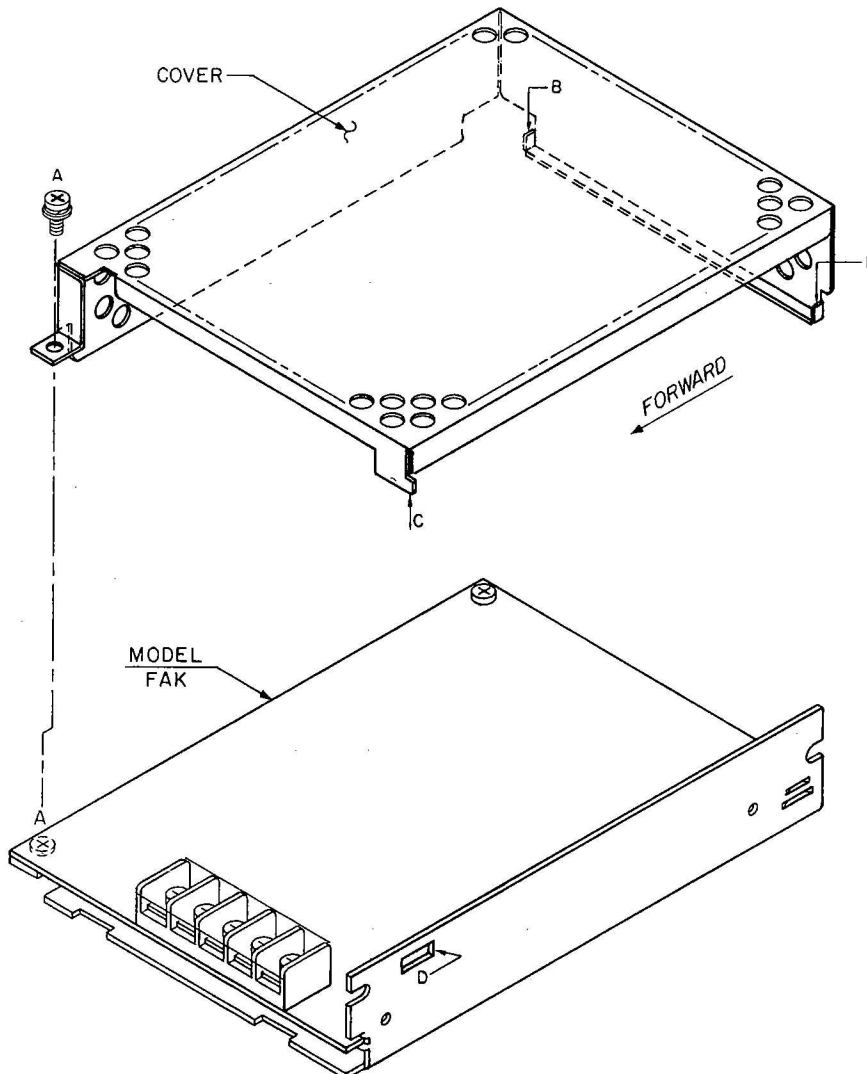

COVER INSTALLATION

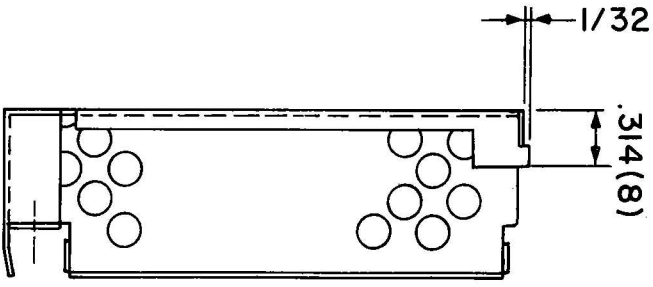
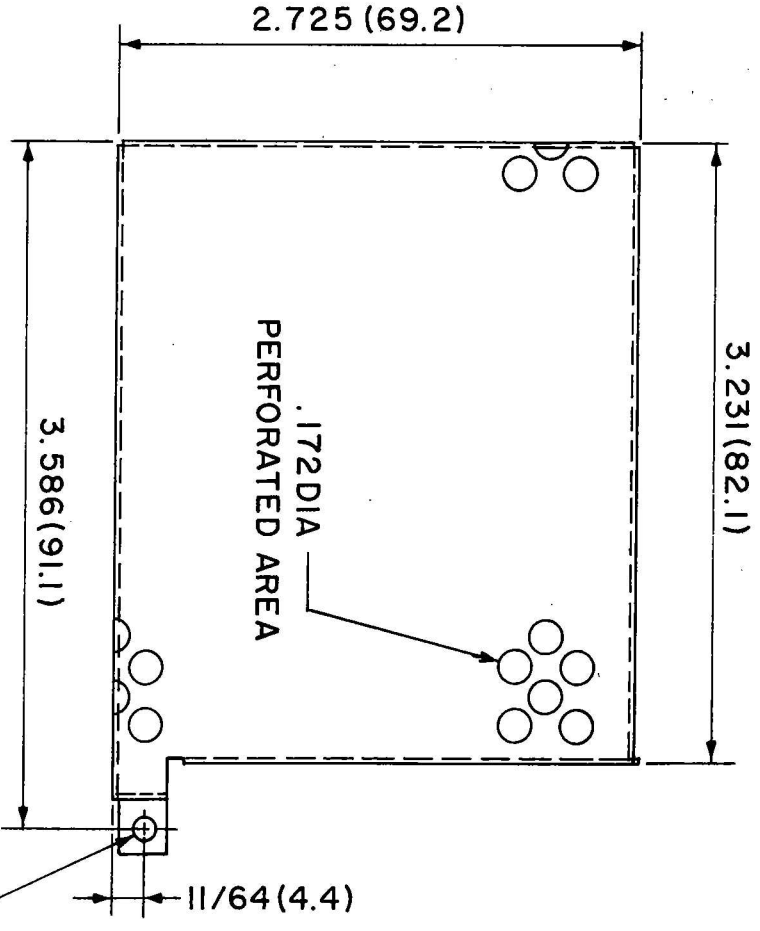
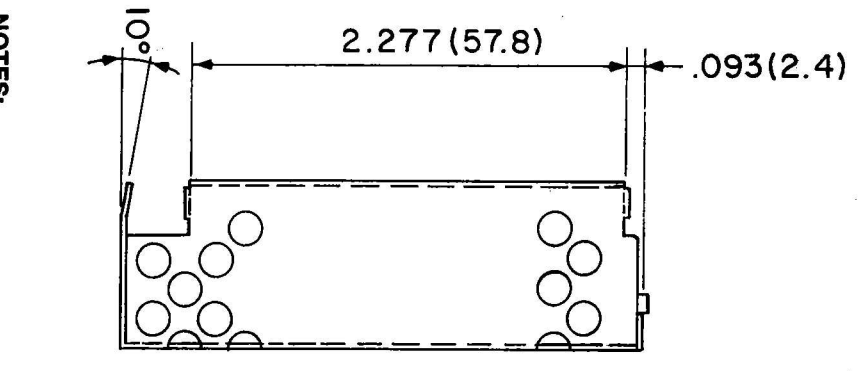
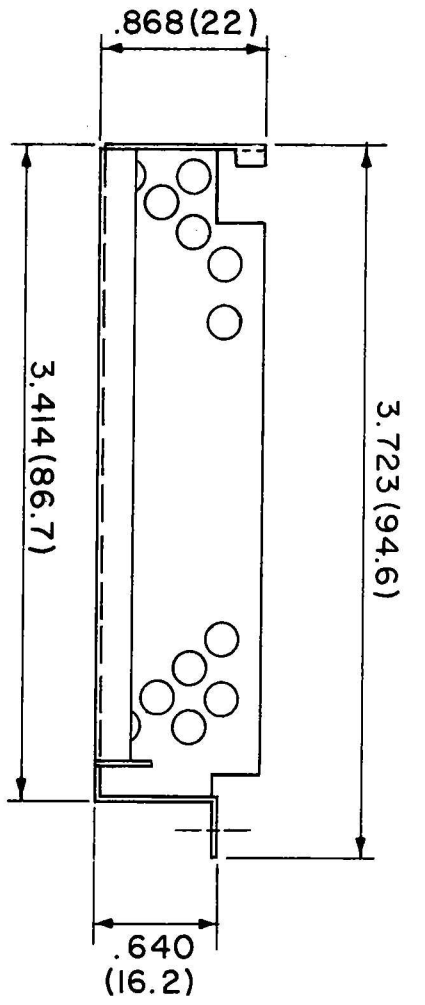

NOTES:

1. Material: 0.024 (0.6) Steel.
2. Finish: Galvanized.
3. Dimensions in parentheses are in millimeters, others in inches.
4. Tolerances: ± 0.04 " (± 1) unless otherwise specified.

MECHANICAL OUTLINE DRAWING

.125 (3.2) DIA. HOLE
FOR M3 SCREW