

INSTRUCTION MANUAL



KEPCO An ISO 9001 Company.

KT
ACCESSORY
EQUIPMENT

CURRENT CONTROL RHEOSTAT CURRENT SENSING RESISTORS

GENERAL DESCRIPTION (Refer to FIG's 1 and 2)

Kepeco Current Sensing and Control Resistors are precision, wire-wound components with low temperature coefficients. The 4-terminal current sensing resistor (R_S) and the 10-turn current control rheostat (R_{CC}) provide all the external circuitry needed to convert a d-c voltage stabilizer into a d-c source supplying stabilized output current. The sensing resistor (R_S), placed in series with the load, provides a voltage drop proportional to the output current. The control rheostat (R_{CC}) is connected to supply feedback from the sensing resistor to the NULL JUNCTION (INVERTING INPUT) of the power supply. In this manner, excellent current stabilization can be achieved over a minimum range of 2% to 100% of I_O max. where I_O max. is the selected maximum power supply output current. (Refer to FIG. 2). The current sensing resistors can also be used for measuring the output current delivered by the power supply.

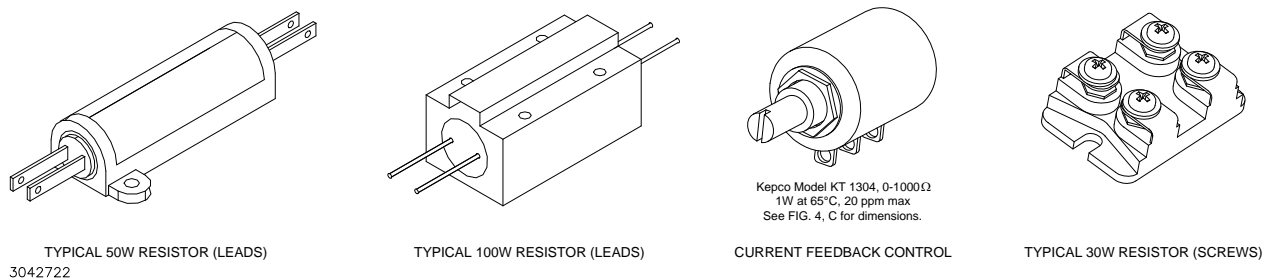

FIGURE 1. KEPCO CURRENT SENSING RESISTORS AND CONTROL RHEOSTAT

TABLE 1. KEPCO SENSING RESISTORS AND CONTROL RHEOSTAT

MODEL	RESISTANCE (OHMS)	TERMINATION	POWER RATING ⁽¹⁾	RECOMMENDED OUTPUT CURRENT RANGE BASED ON 1-VOLT SAMPLE		OUTLINE DIMENSIONS
				LOW	HIGH	
KT 1304	1000	TERMINALS	2W	N/A	N/A	SEE FIG. 4, C
KT 1915	1.0	LEADS	50W	0.02A	1A	SEE FIG. 4, A
KT 1385	0.667	LEADS	50W	0.03A	1.5A	SEE FIG. 4, A
KT 1399	0.5	LEADS	50W	0.04A	2A	SEE FIG. 4, A
KT 1386	0.333	LEADS	50W	0.06A	3A	SEE FIG. 4, A
KT 1598	0.2	LEADS	50W	0.01A	5A	SEE FIG. 4, A
KT 2356	0.1	LEADS	50W	0.2A	10A	SEE FIG. 4, A
KT 2713	0.01	LEADS	50W	N.A. ⁽²⁾	N.A. ⁽²⁾	SEE FIG. 4, A
KT 2537	0.0625	LEADS	100W	0.32A	16A	SEE FIG. 4, B
KT 2536	0.05	LEADS	100W	0.4A	20A	SEE FIG. 4, B
KT 2480	0.033	LEADS	100W	0.6A	30A	SEE FIG. 4, B
KT 2330	0.02	LEADS	100W	1A	50A	SEE FIG. 4, B
KT 2325	0.01	LEADS	100W	2A	100A	SEE FIG. 4, B
KT 2714	0.001	LEADS	100W	N.A. ⁽²⁾	N.A. ⁽²⁾	SEE FIG. 4, B
KT 3146	1	SCREW	30W	0.02A	1A	SEE FIG. 4, D
KT 3126	0.1	SCREW	30W	0.2A	10A	SEE FIG. 4, D
KT 3130	0.01	SCREW	30W	1A	50A	SEE FIG. 4, D
KT 3131	0.001	SCREW	30W	2A	100A	SEE FIG. 4, D

⁽¹⁾ A suitable heatsink must be provided, See "INSTALLATION" paragraph.
Power Rating based on 275 °C max. hot spot temperature in 25 °C ambient, derate to 80% power in 71 °C ambient.

⁽²⁾ These sensing resistors are designed to provide a 0-200mV sample voltage for currents of 20A (KT 2713) and 200A (KT 2714) respectively.

KEPCO, INC. ● 131-38 SANFORD AVENUE ● FLUSHING, NY. 11355 U.S.A. ● TEL (718) 461-7000 ● FAX (718) 767-1102
www.kepcopower.com ● email: hq@kepcopower.com

SENSING RESISTOR SELECTION

The value of the sensing resistor (R_S) is selected according to the desired output current range, such that a 1-volt sample is provided at the maximum output current ($I_O \text{ MAX}$):

$$R_S = \frac{1 \text{ Volt}}{I_O \text{ Max.}} \quad (\text{See Table 1 for values.})$$

INSTALLATION

The minimum required heat sink area for the listed power rating of the current sensing resistors is 144 square inch, 1/4 in. thick aluminum (950 square centimeters, 0.5 centimeters thick). **If the actual power dissipation (MAXIMUM OUTPUT CURRENT TIMES ONE VOLT) exceeds one-tenth of the power rating, additional cooling by means of an air stream or an oil-bath should be provided to keep the heat-rise in the sensing resistor to a minimum.** To minimize output ripple ("pick-up") mount the sensing resistor assembly as close to the power supply as practicable. Use shielded cable to connect the current control resistor to the null junction of the power supply and connect the shield (single-ended) to the common signal ground.

INTERCONNECTIONS

The simplified connecting diagram (refer to FIG. 2) shows the electrical connection of the Sensing and Control Resistors to a typical Kepco Power Supply. The nomenclature used in the diagram coincides with that used on all Kepco Power Supplies. Refer to your Kepco Instruction Manual when in doubt about interconnections or terminal designations.

NOTE: If the load must be protected from excessive compliance (output) voltage, a zener diode, rated to conduct at the desired voltage, should be connected as shown in FIG. 2.

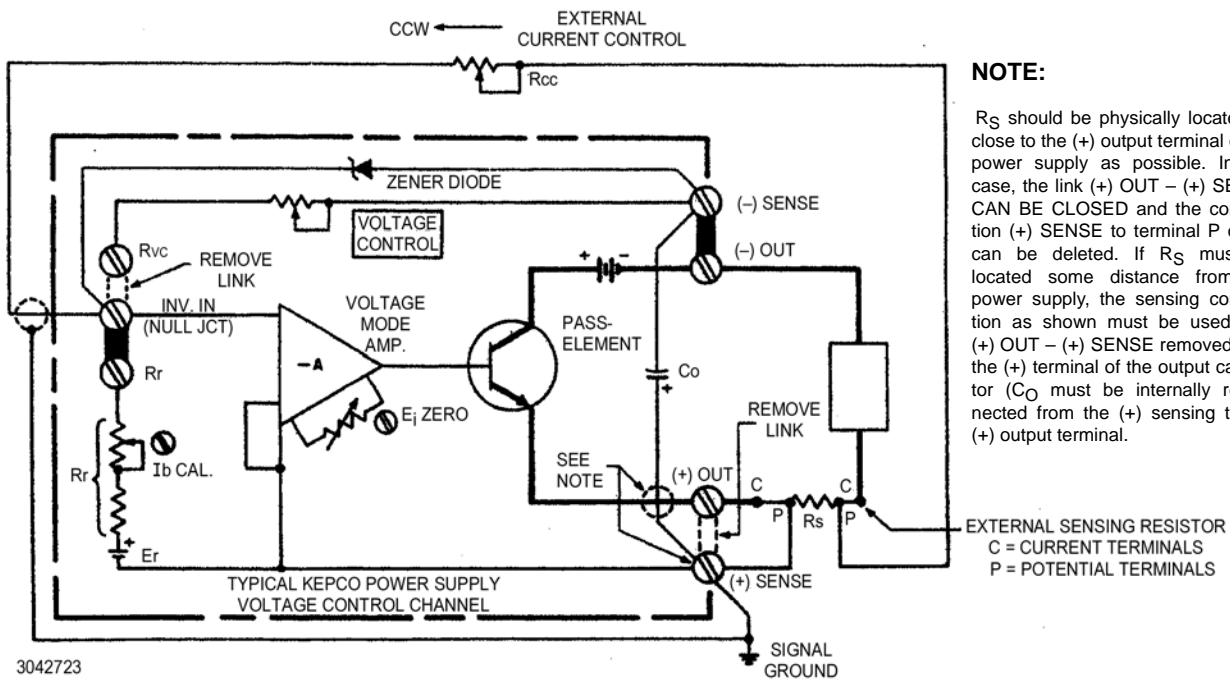

NOTE:

R_S should be physically located as close to the (+) output terminal of the power supply as possible. In this case, the link (+) OUT - (+) SENSE CAN BE CLOSED and the connection (+) SENSE to terminal P of R_S can be deleted. If R_S must be located some distance from the power supply, the sensing connection as shown must be used (link (+) OUT - (+) SENSE removed) and the (+) terminal of the output capacitor (C_O) must be internally reconnected from the (+) sensing to the (+) output terminal.

FIGURE 2. EXTERNAL CURRENT SENSING AND CONTROL USING THE VOLTAGE MODE AMPLIFIER

CALIBRATION PROCEDURE

The Kepco power supply, now converted to supply stabilized output current, can be calibrated by means of its built-in I_b CAL and E_{i0} ZERO controls and by adding a precision ammeter (or a voltmeter parallel to the sensing resistor) in series with the load. If the power supply lacks the calibration controls, they may be added externally to most Kepco power supplies. (Refer to your Kepco Instruction Manual). Connect the load, the calibrating instrument and the external components as shown in FIG. 3. Proceed as follows:

1. Turn calibration set-up "on" and allow for a sufficient warm-up period. (Warm-up time depends on the environmental temperature, the power supply output power and the effectiveness of the heat-sink on which the external sensing resistor is mounted.)
2. Turn the external current control resistor (R_{CC}) through its range to check for smooth operation over the selected range. Set (R_{CC}) to "zero ohms" (CCW).
3. Observe the calibrating meter (M1). Correct zero point by adjusting the built-in (or external) E_{i0} ZERO control.
4. Turn (R_{CC}) to its maximum resistance position (CW). Observe M1. Correct maximum output current point by adjusting the built-in (or external) I_b CAL control.
5. Recheck "zero" point by repeating procedure described in steps 2 and 3 above.

NOTE: The limitation imposed by using a single sensing resistor and by parallel leakage paths inside the power supply restrict the usable output current range, obtainable with the described method, to approximately 2% to 100% I_O max. If current control over a wider range is desired, two or more ranges can be implemented, each range requiring its own sensing resistor, calculated on the basis of a 1-volt sensing voltage at the maximum range current. For a power supply with a maximum rated output current of 50 amperes for example, two sensing resistors (Model KT 1915 and Model KT 2330) would cover the ranges from 0.02 Ampere to 1 Ampere and from 1 Ampere to 50 Amperes. (See Table 1.)

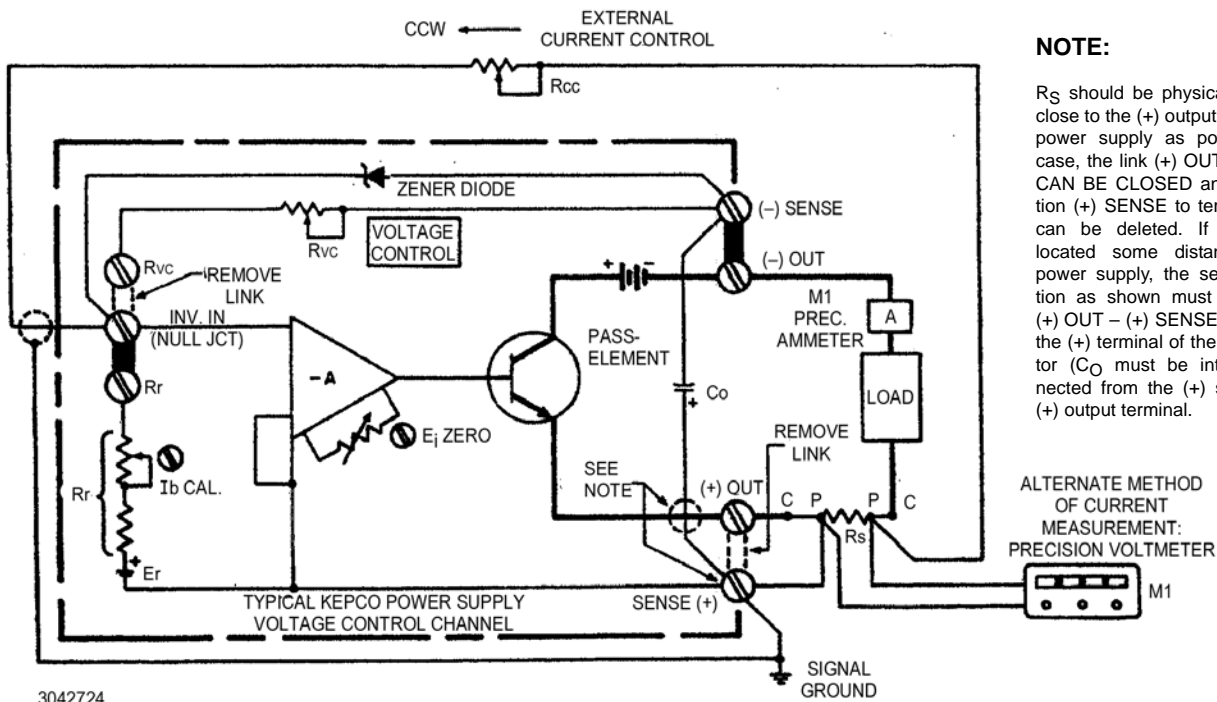
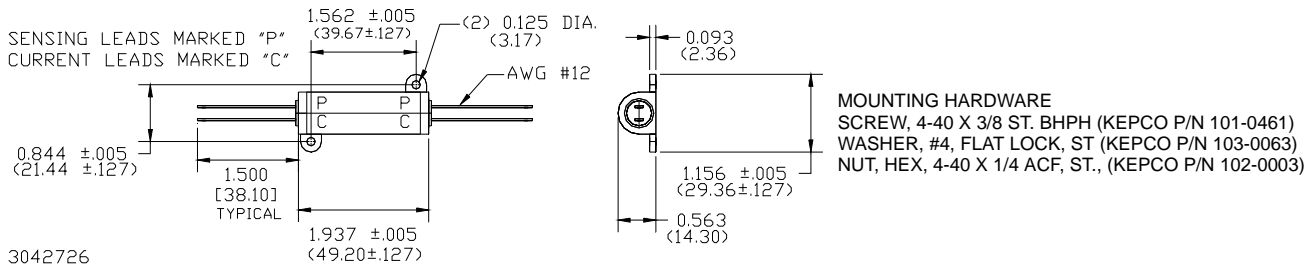

FIGURE 3. CALIBRATION SET-UP

NOTE: Dimensions shown in parentheses are in millimeters.

A. TYPICAL 50W RESISTOR (LEADS)



B. TYPICAL 100W RESISTOR (LEADS)

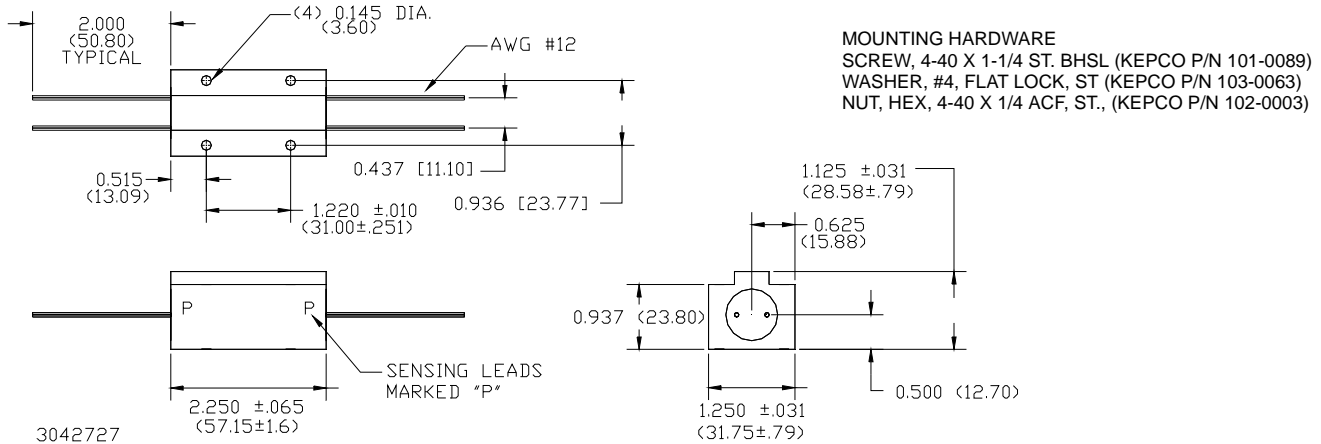

C. KT 1304 CURRENT CONTROL RHEOSTAT

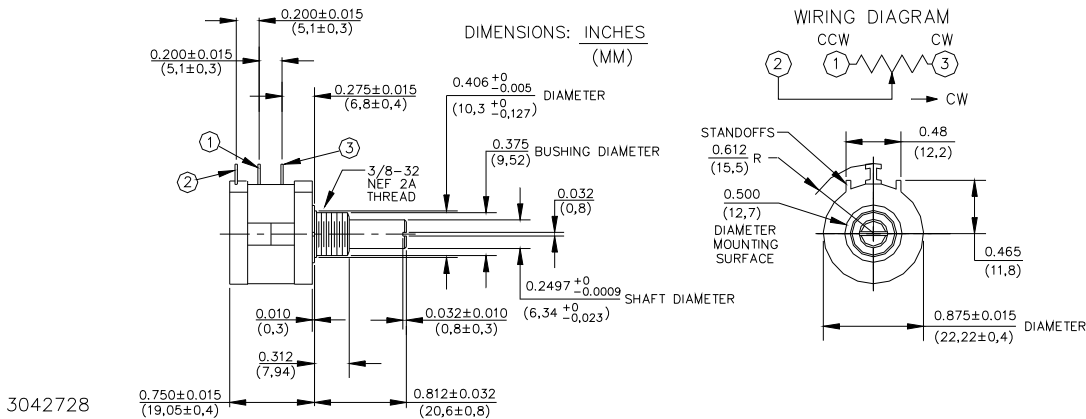

D. TYPICAL 30W RESISTOR (SCREWS)

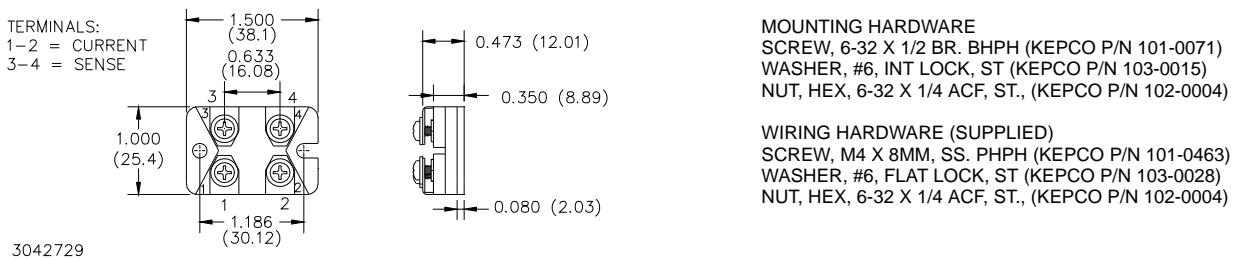

FIGURE 4. MECHANICAL OUTLINE DIMENSIONS