

MOUNT WITH (2) 6-32 x 3/8 PHILLIPS SCREW
#101-0244
(BLACK NICKEL) AND (2) BLACK NYLON WASHER
#103-0147

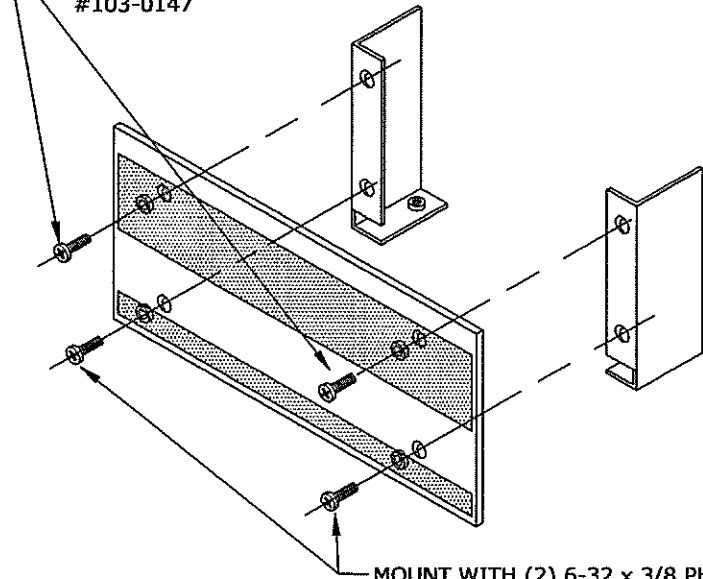

MOUNT WITH (2) 6-32 x 3/8 PHILLIPS SCREW #101-0156
(CADMIUM PLATED) AND (2) WHITE NYLON WASHER #103-0107

PANEL ASSEMBLY

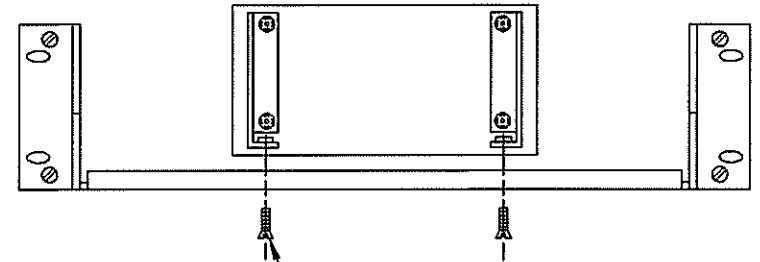

MOUNT WITH (2) 8-32 x 1/2 FLAT HEAD SCREW
#101-0027

RACK ADAPTER ASSEMBLY (REAR)

NOTE

1. PANELS: MAT'L. ALUMINUM ALLOY 1/8 THICK.
FINISH : LIGHT GRAY PER FEDERAL STD. 595
COLOR #26440. ONE SIDE IS ADDITIONALLY
TRIMMED DARK CHARCOAL GRAY SIMILAR
TO HARTIN 6406.
2. MOUNTING BRACKETS: MAT'L. 16 GA COLD ROLLED STEEL
FINISH: CADMIUM PLATED WITH A YELLOW
CHROMATE WASH



TITLE

INSTALLATION INSTRUCTIONS

MODEL NO. RFP 37-1,-2,-3	PART NO. 228-0769	SCALE: NA
DWG. NO. BM15094	SHEET:	REV.