



■ **Features :**

- Universal AC input 88 - 264Vac
- Installed on DIN rail TS35 / 7.5 or 15
- Brown-out protection
- Protections: Short circuit / Over load / Over voltage
- All using 105°C long life electrolytic capacitors
- High operation temperature up to 70°C
- True DC OK signal output
- Withstand 2G vibration test
- High efficiency , long life and high reliability
- 3 years warranty
- UL508 (Industrial control equipment) listed
- UL1310 Class 2 Power unit / LPS pass



MODEL		DN-100-12	DN-100-15	DN-100-24	DN-100-48
Output	DC Voltage Range	12V	15V	24V	48V
	Rated Current	7.5A	6.4A	4A	2A
	Current Range	0 ~ 7.5A	0 ~ 6.4A	0 ~ 4A	0 ~ 2A
	Rated Power	90W	96W	96W	96W
	Ripple & Noise (max.)	Note.2 180 mVp-p	180 mVp-p	180 mVp-p	250 mVp-p
	Voltage Adj. Range	10.8 ~ 13.2V	13.5 ~ 16.5V	21.6 ~ 26.4V	43.2 ~ 52.8V
	Voltage Tolerance	Note.3 ±1%	±1%	±1%	±1%
	Line Regulation	±1%	±1%	±1%	±1%
	Load Regulation	±2%	±2%	±2%	±2%
	Setup, Rise Time	<800ms, <40ms / 230VAC at full load			
Hold Up Time (Typ.)	> 32ms / 230VAC, >16ms / 115VAC at full load				
Input	Voltage Range	Note.4 88 ~ 264VAC	124 ~ 370VDC		
	Frequency Range	47Hz ~ 63Hz			
	Power Factor (Typ.)	<0.92 / 230VAC	<0.98 / 115VAC at full load		
	Efficiency (Typ.)	87%	87%	88%	87%
	AC Current (Typ.)	1.1 A / 115VAC	0.55A / 230VAC		
	Inrush Current (Typ.)	COLD START 30A / 115VAC 60A / 230VAC			
	Leakage Current	<1mA / 230VAC			
Protection	Over Load	> 102 % rated output power Protection type : constant current limiting, automatically after fault condition is removed			
	Over Voltage	115% ~ 150% rated output voltage Protection type : latch-off mode			
Environment	Working Temp.	-20°C ~ +70°C (Refer to output load de-rating curve)			
	Working Humidity	20 ~ 90% R.H non-condensing			
	Storage Temp., Humidity	-40 ~ +85°C 10 ~95% R.H			
	Temp.Coefficient	±0.03%/°C (0 ~ 50°C)			
Safety & EMC	Vibration	10 ~ 500Hz, 2G 10min./1cycle, period for 60 min. Each along X,Y,Z axes			
	Safety Standards	UL508, TUV EN60950-1 : 2006+A11, UL1310 NEC class 2 compliant			
	Withstand Voltage	I/P - O/P : 4242 DC I/P - FG : 2121 DC 1 minute			
	Isolation Resistance	I/P - O/P, I/P - FG, O/P - FG: 100M Ω / 500VDC			
	EMI Conduction & Radiation	EN55022 : 2006 Class B			
Others	Harmonic Current	EN61000-3-2: 2006 Class A, EN61000-3-3: 1995+A1: 2001+A2: 2005			
	EMS Immunity	EN61204-3: 2000, EN55024:1998+A1: 2001+A2: 2003 light industry level, criteria A			
	DC OK signal	Relay contact (24VDC / 1A, 120VAC / 1A)			
	Connection	I/P 3 poles, O/P : 6 poles screw DIN terminal			
	MTBF(MIL-HDBK-217F)	120.4K HRS			
	Cooling	Free Air convection			
Note	Dimension (W*H*D)(mm)	55x90x99			
	Packing	0.4kg ; 24Pcs / 10.8kg			
1. All parameters NOT specially mentioned are measured at 230VAC input, rated load and 25°C of ambient temperature. 2. Ripple & noise are measured at 20MHz of bandwidth by using a 12" twisted pair-wire terminated with a 0.1uf & 47 uf parallel capacitor. 3. Tolerance: includes set up tolerance, line regulation and load regulation. 4. De-rating may be needed under low input voltages. Please check the de-rating curve for more details. 5. The power supply is considered a component which will be installed into a final equipment. The final equipment must be re-confirmed that it still meets EMC directives.					



Mechanical Specification

Unit : mm

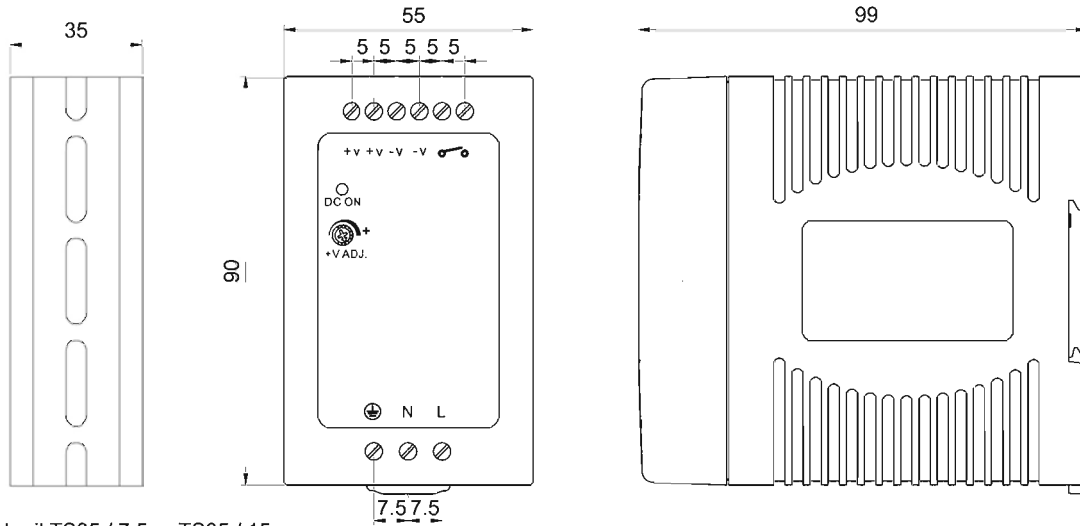

install DIN rail TS35 / 7.5 or TS35 / 15

Block Diagram

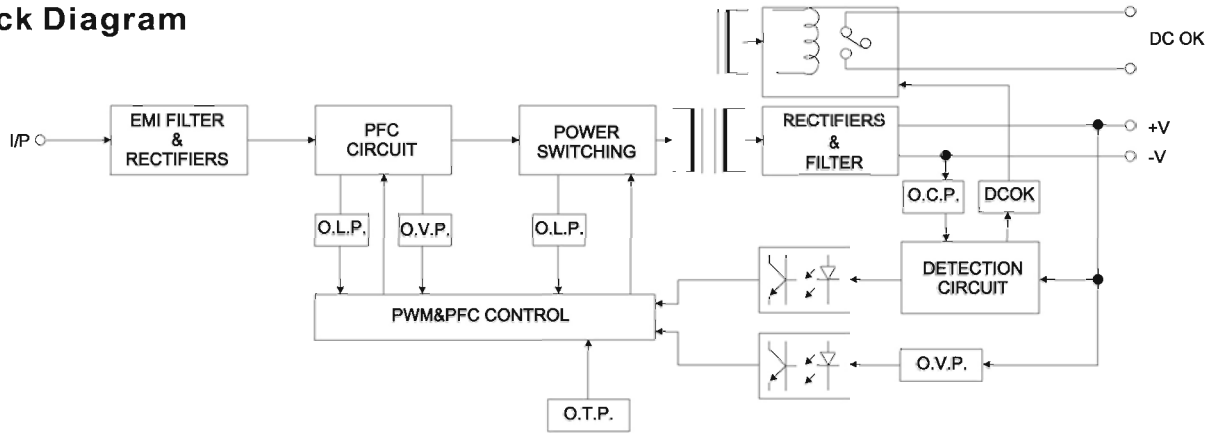

DC OK Relay Contact

Contact Close	When the output voltage reaches the adjusted output voltage
Contact Open	When the output voltage drop below 90% output voltage
Contact Ratings (max.)	30V / 1A resistive load

De-rating Curve

Load V.S Temp.

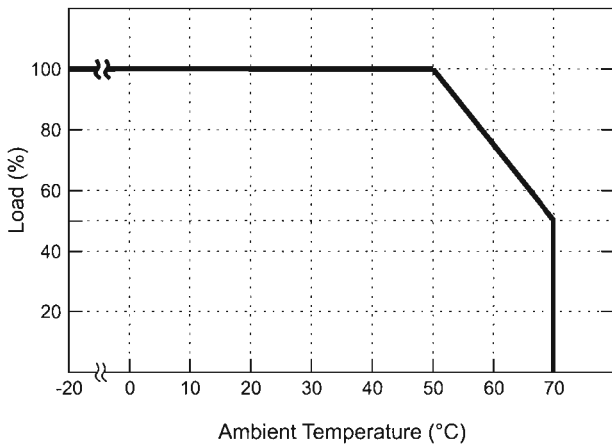

Load V.S I/P Voltage

