

**Features :**

- Universal AC input with active PFC
- Programmable output Voltage (30% ~ 105%)
- Programmable output Current (40% ~ 105%)
- High efficiency up to 91%
- +5V / 0.5A auxiliary output
- Intelligent LED indicators
- 1U profile, High power density
- Forced current sharing at parallel operation
- Power OK signal (Power good, Logic low)
- Remote ON-OFF, Remote sense function
- Protections : OVP, OLP, OTP, SCP, Fan failure
- 3 years warranty



MODEL		AK-650-05	AK-650-12	AK-650-15	AK-650-24	AK-650-27	AK-650-48	
Output	DC Voltage Range	5V	12V	15V	24V	27V	48V	
	Rated Current	100A	50A	40A	27A	24A	13.6A	
	Current Range	0~100A	0~50A	0~40A	0~27A	0~24A	0~13.6A	
	Rated Power	500W	600W	600W	648W	648W	652W	
	Ripple & Noise (Max.)	Note.2 150mVp-p	150mVp-p	150mVp-p	150mVp-p	150mVp-p	150mVp-p	
	Voltage Adj. Range	±5.0% Typical adjustment by potentiometer						
	Voltage Tolerance	Note.3 ±1.0%						
	Line Regulation	±0.5%						
	Load Regulation	±0.5%						
	Setup, Rise Time	800ms, 60ms at full load						
Hold Up Time (Typ.)	16ms / 230VAC at full load							
Input	Voltage Range	Note.4 90 ~ 264VAC	127 ~ 370VDC					
	Frequency Range	47 ~ 63Hz						
	Power Factor (Typ.)	0.98 / 230VAC, 0.99 / 115VAC at full load						
	Efficiency (Typ.)	83%	88%	88%	90%	90%	91%	
	AC Current (Typ.)	7.5A / 115VAC 3.5A / 230VAC						
	Inrush Current (Typ.)	27A / 115VAC 54A / 230VAC						
Leakage Current	<1.0mA / 240VAC							
Protection	Over Load	105 ~ 125% rated output power						
		Protection type : Total Power limiting, Latch-style (Recovery after reset AC power ON or inhibit)						
	Over Voltage	Variable OVP, 125% ± 10% Vout. Protection type: Latch-style (Recovery after reset AC power ON or inhibit)						
Over Temperature		By detecting primary and secondary heat sink.						
		Protection type: Shut down o/p voltage (Auto recovers automatically after temperature goes down)						
Function	Auxiliary Power	5V @ 0.5A (+/- 3%)						
	Remote ON/OFF Control	External switch or NPN Transistor to turn ON / OFF						
	Power OK Signal	Open drain signal low when PSU turns on, Max. sink current: 20mA, Max. drain voltage: 40V.						
	Output Voltage Trim	Adjustment of output voltage is between 30 ~ 105% of rated output						
	Output Current Trim	Adjustment of output current is between 40 ~ 105% of rated output						
Parallel (Current Sharing)	Note.5	Please refer to function						
Environment	Working Temp.	-25 ~ +60°C (Refer to output load de-rating curve)						
	Working Humidity	20 ~ 90% R.H non-condensing						
	Storage Temp., Humidity	-40~+85°C, 10 ~95% R.H						
	Temp. Coefficient	±0.02%/°C (0 ~ 50°C)						
	Vibration	10 ~ 500Hz, 5G 10min./1 cycle, period for 60 min each along X,Y,Z axes Compliance to IEC 68-2-6, IEC 68-2-64						
Safety & EMC	Safety Standards	UL 60950-1, 2 nd Edition, TUV EN60950-1 : 2006+A11 Approved						
	Withstand Voltage	I/P-O/P: 3KVAC I/P-FG: 1.5KVAC O/P-FG: 0.5KVAC						
	Isolation Resistance	I/P-O/P, I/P-FG, O/P-FG: 100MQ / 500VDC						
	EMI Conduction & Radiation	EN55022: 2006 Class B						
	Harmonic Current	EN61000-3-2: 2006 Class A, EN61000-3-3: 1995+A1: 2001+A2: 2005						
EMS Immunity	EN55024: 1998+A1: 2001+A2: 2003 light industry level, criteria A							
Other	MTBF	166.2K HRS MIL-HDBK-217F						
	Cooling	Controlled by power rating & temperature (Internal ball bearing fan)						
	Dimension (L*W*H)	249x127x41 mm / 9.80x5.00x1.61 inch						
	Packing	1.68 kg ; 6pcs / 11.085kg / 0.75 CUFT						
Note	<p>1. All parameters NOT specially mentioned are measured at 230VAC input, rated load and 25°C of ambient temperature.</p> <p>2. Ripple & noise are measured at 20MHz of bandwidth by using a 12" twisted pair-wire terminated with a 0.1uf & 47 uf parallel capacitor.</p> <p>3. Tolerance: includes set up tolerance, line regulation and load regulation.</p> <p>4. De-rating may be needed under low input voltages. Please check the de-rating curve for more details.</p> <p>5. In parallel connection, maybe only one unit operate if the total output load is less than 5% of rated load condition.</p> <p>6. The power supply is considered a component which will be installed into a final equipment. The final equipment must be re-confirmed that it still meets EMC directives.</p>							

Unit : mm / inch

Mechanical Specification

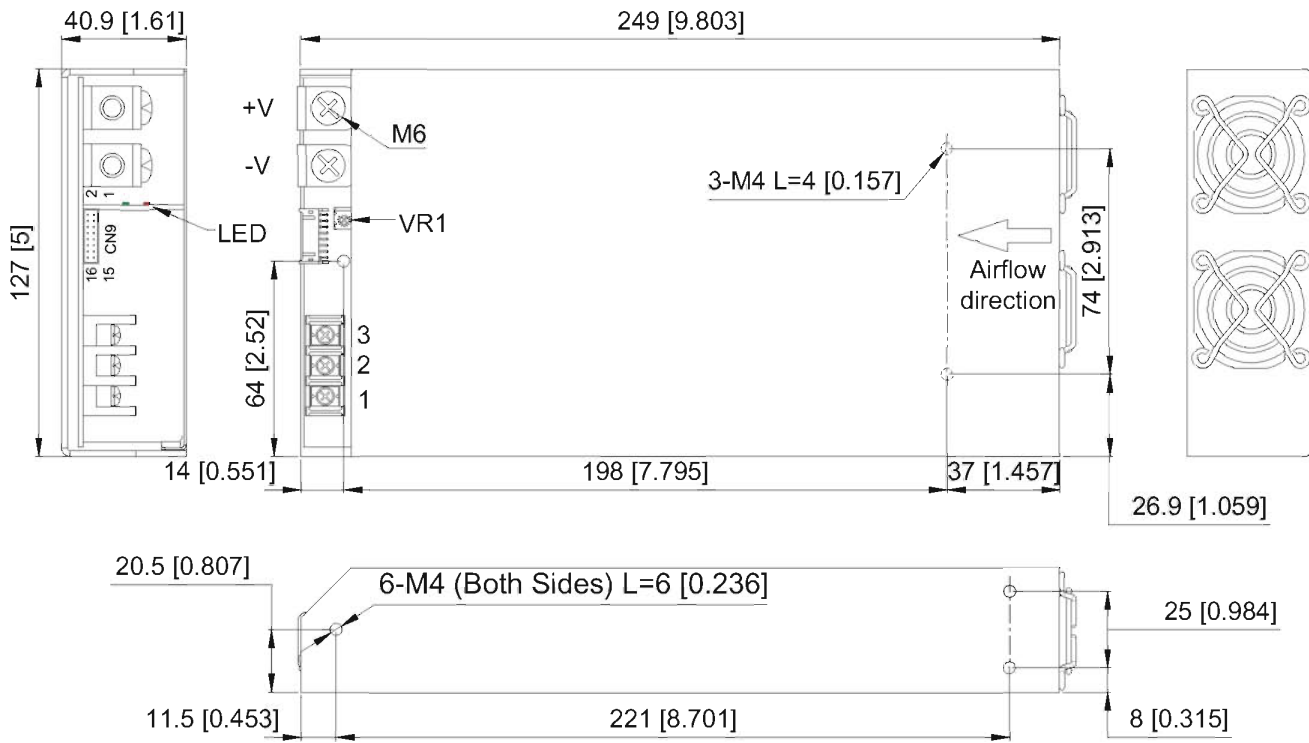

AC Input Terminal
Pin No. Assignment

Pin No.	Assignment
1	ACL
2	ACN
3	⏏

Control pin number assignment (CN9) : JST S16B-PHDSS or equivalent

Pin No.	Assignment	Pin No.	Assignment	Pin No.	Assignment	Pin No.	Assignment	Mating Housing	Terminal
1	VS+	5	AUX	9	EN-	13	VCI	PHDR-16VS	SPHD-002T-P05
2	VO+	6	AUX	10	GND	14	GND		
3	VS-	7	EN+	11	P.OK	15	PAR		
4	VO-	8	GND	12	GND	16	ACI		

Function Description of CN9

Pin No.	Function	Description
1	VS+	Remote voltage sense (+)
2	VO+	Local output voltage sense (+)
3	VS-	Remote voltage sense (-)
4	VO-	Local output voltage sense (-)
5,6	AUX	+5V / 0.5A Auxiliary power
7	EN+	Remote ON/OFF (+)
8,10,12,14	GND	Ground
9	EN-	Remote ON/OFF (-)
11	P.OK	Power OK
13	VCI	V Program
15	PAR	Parallel operation current share
16	ACI	I Program



LED Status

Green LED	LED Signal	Status
Solid		Power OK
Slow Blink		Power Standby
Red LED	LED Signal	Status
Fast Blink		Over Voltage Protection (OVP)
Solid		Over Load Protection (OLP)
		Output Shorted Circuit Protection (SCP)
		Under Voltage Protection (UVP)
Slow Blink		Over Temperature Protection (OTP)
Intermittent Blink		Fan Failure
Interlace Blink		Power Failure

De-rating Curve

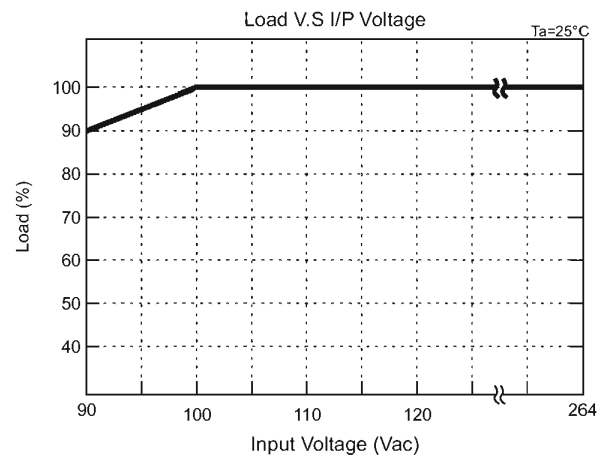
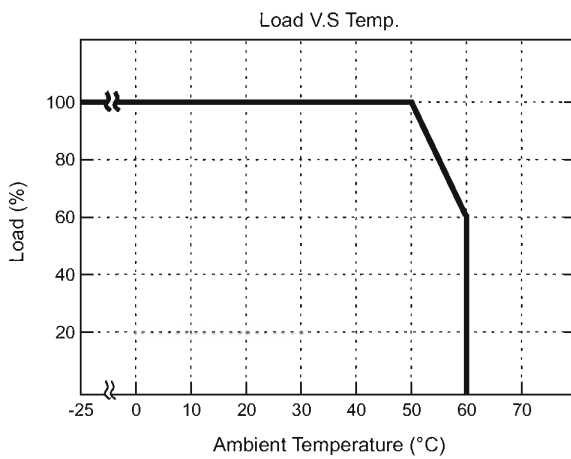

Function Manual

1. Output Voltage Trim

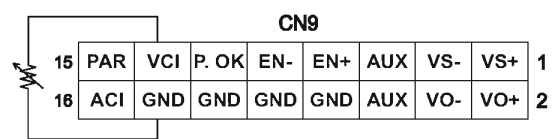
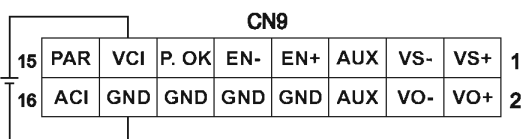
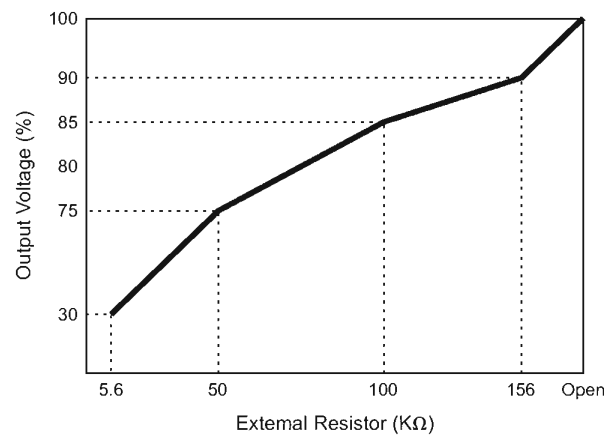
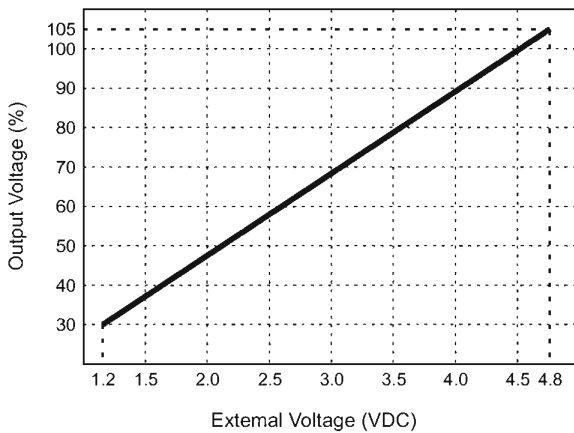

2. Output Current Trim (For Reference Only)

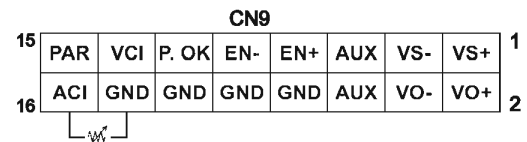
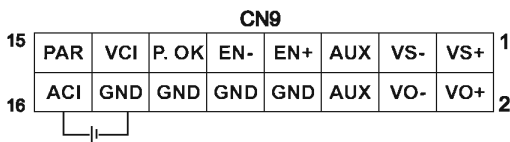
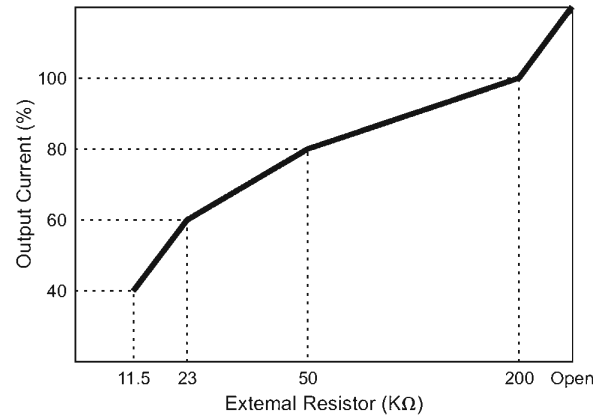
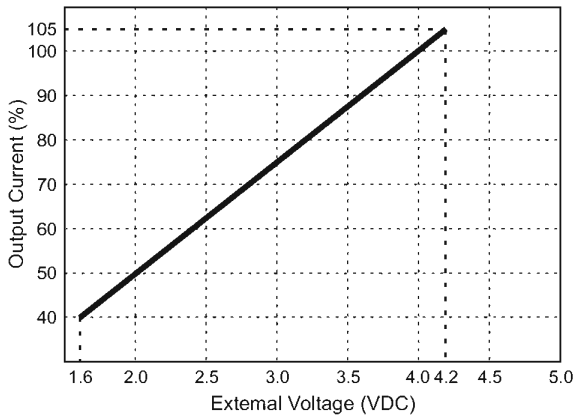

3. Remote ON/OFF

(A)

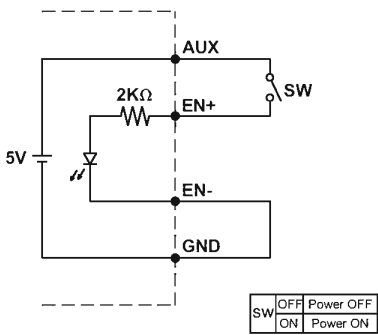

(A) Using internal 5V auxiliary source

(B)

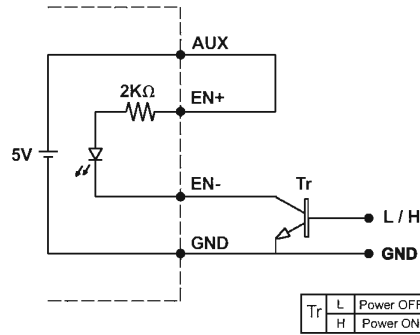

(B) ON / OFF Control by NPN transistor

(C)

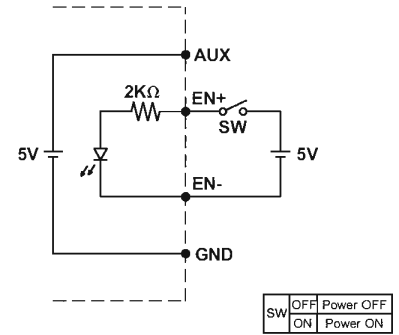

(C) Using external voltage source

4. Power OK Signal

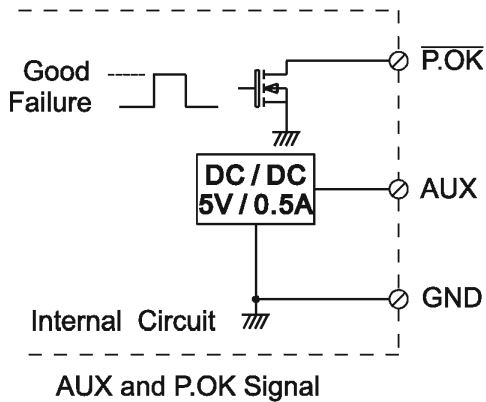

*Place an additional capacitor to have a better performance of auxiliary power operation.

*The grounding of "AUX" power should be connected to "GND" port. If "V-" is connected as Grounding, make sure to short the GND and V- ports.

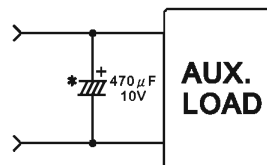



5. Remote Sense

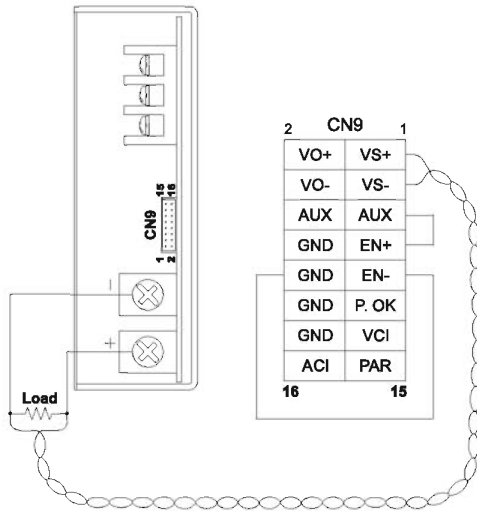

6. Local Sense

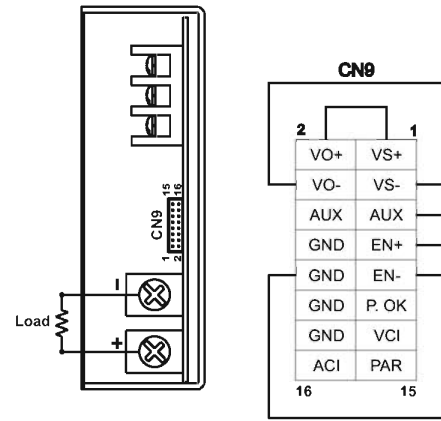

7. Current Sharing with Remote Sensing

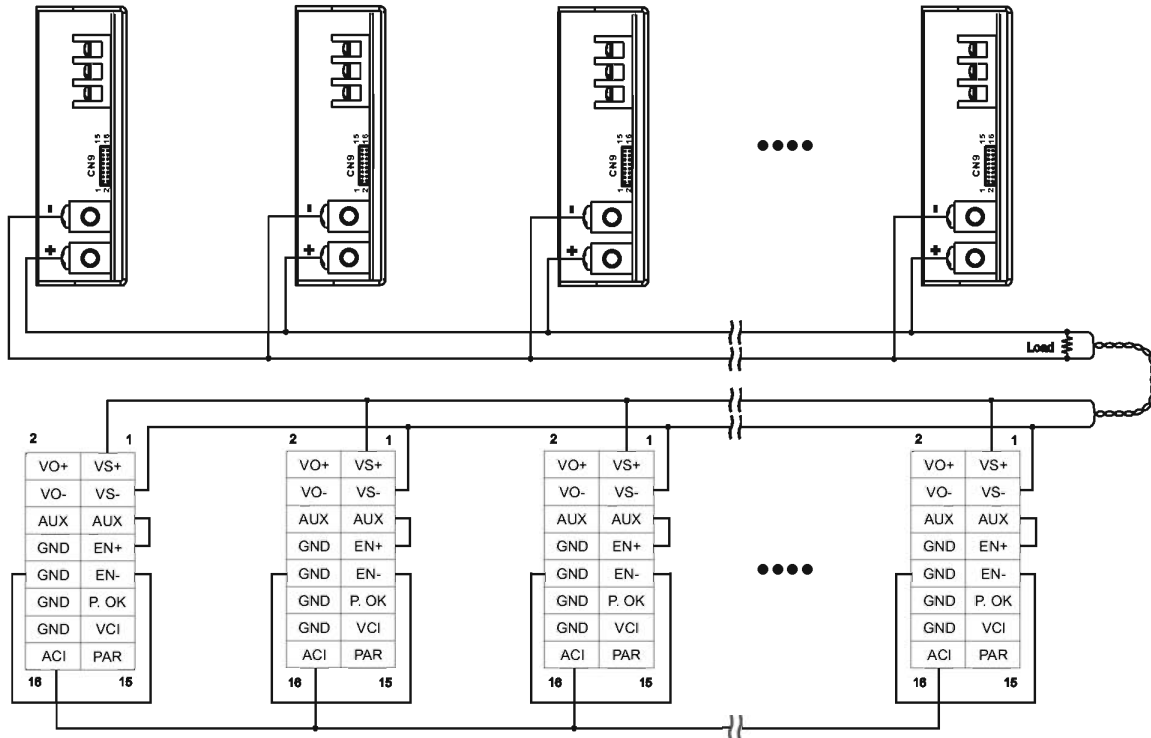

8. Current Sharing with Local Sensing

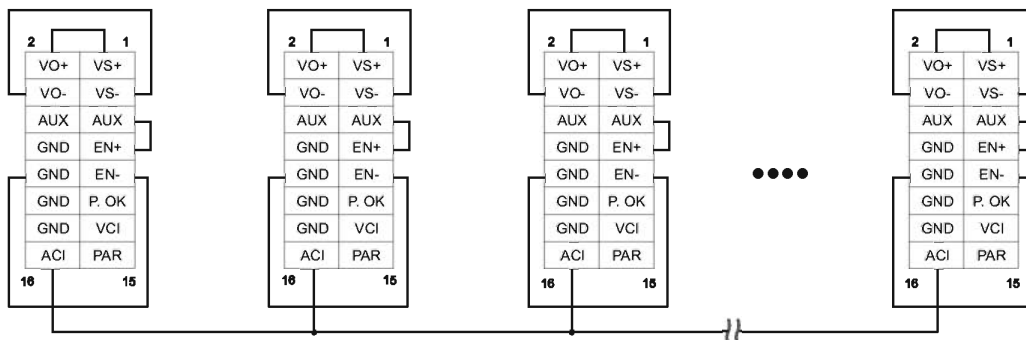

Installation Instruction

1. Mounting Directions

1-1 Recommended standard mounting methods:

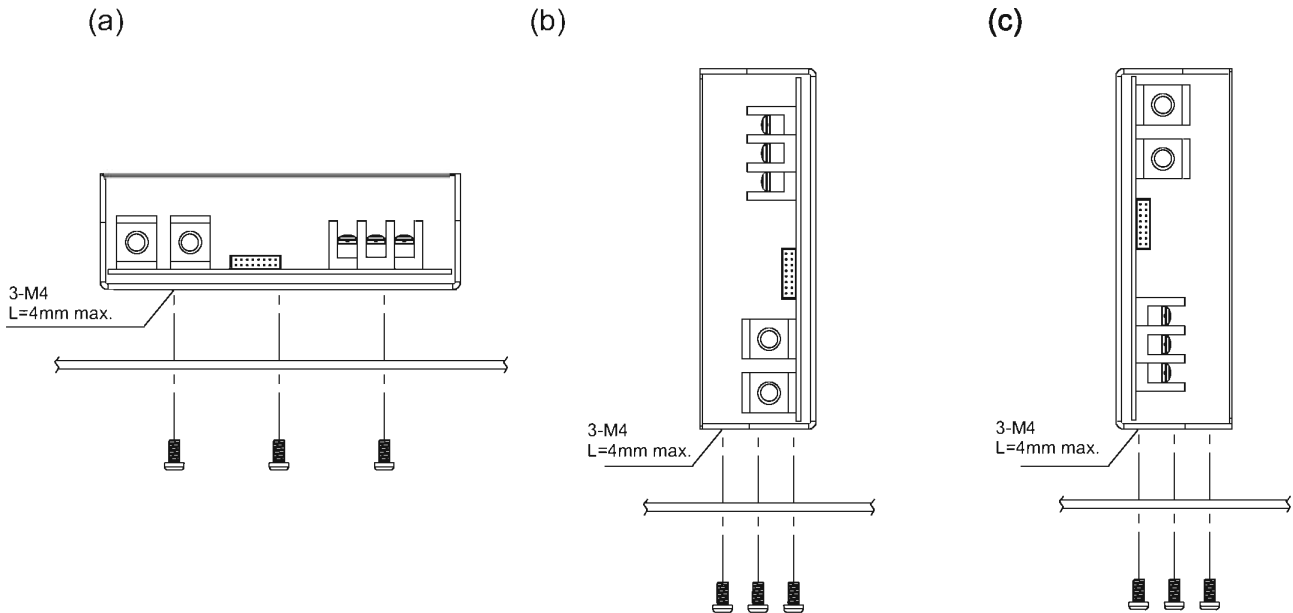

2. Mounting Method

2-1 There are ventilating holes on the front and back side panels, do not obstruct; allow 50mm at least for air flow.

2-2 The Maximum allowable penetration of screw is 4mm. Incomplete threading should not be penetrated.

2-3 Recommended the torque of mounting screw:
 M4 screw: 1.27N • m (13.0kgf • cm)

