



Features:

- Universal AC input / Full range
- Programmable output Voltage (30% ~ 105%)
- Programmable output Current (40% ~ 105%)
- +5V / 0.5A auxiliary output
- 1U profile, High power density 11.1W / in³
- Forced current sharing at parallel operation
- Power OK signal
- Remote ON / OFF, Remote sense function
- Protection: OVP, OLP, OTP, SCP, Fan failure
- 3 years warranty

MODEL		AK-1000-12	AK-1000-15	AK-1000-24	AK-1000-27	AK-1000-48
Output	DC Voltage Range	12V	15V	24V	27V	48V
	Rated Current	62A	50A	40A	37A	21A
	Current Range	0 ~ 62A	0 ~ 50A	0 ~ 40A	0 ~ 37A	0 ~ 21A
	Rated Power	744W	750W	960W	999W	1008W
	Ripple & Noise (Max.)	Note.2 150mVp-p	150mVp-p	150mVp-p	150mVp-p	150mVp-p
	Voltage Adj. Range	±5.0% Typical adjustment by potentiometer. (VR1)				
	Voltage Tolerance	Note.3 ±1.0%				
	Line Regulation	±0.5%				
	Load Regulation	±0.5%				
	Setup, Rise Time	800ms, 60ms at full load				
Hold Up Time (Typ.)	16ms / 230VAC at full load					
Input	Voltage Range	Note.4 90 ~ 264VAC, 127 ~ 370VDC				
	Frequency Range	47 ~ 63Hz				
	Power Factor (Typ.)	0.98 / 230VAC, 0.99 / 115VAC at full load				
	Efficiency (Typ.)	87%	88%	89%	89%	90%
	AC Current (Typ.)	12A / 115VAC, 5A / 230VAC				
	Inrush Current (Typ.)	27A / 115VAC, 54A / 230VAC				
Leakage Current	< 1.0mA / 240VAC					
Protection	Over Load	105% rated output power Protection type: Total Power limit, Latch-style (Recovery after reset AC power ON or inhibit)				
	Over Voltage	Variable OVP, 125 ± 10% Vout. Protection type: Latch-style (Recovery after reset AC power ON or inhibit)				
	Over Temperature	By detecting primary and secondary heat sink. Protection type: Shut down o/p voltage (Auto recovers automatically after temperature goes down)				
Function	Auxiliary Power	5V / 0.5A (±3%)				
	Remote ON / OFF Control	External switch or NPN Transistor to turn ON / OFF				
	Power OK Signal	Open drain signal low when PSU turns on, Max. sink current: 20mA, Max. drain voltage: 40V.				
	Output Voltage Trim	Adjustment of output voltage is between 30 ~ 100% of rated output				
	Output Current Trim	Adjustment of output current is between 40 ~ 105% of rated output				
	Parallel (Current Sharing)	Note.5	Please refer to function			
Environment	Working Temp.	-25 ~ +60°C (Refer to output load de-rating curve)				
	Working Humidity	20 ~ 90% RH non-condensing				
	Storage Temp. & Humidity	-40 ~ +85°C, 10 ~ 95% RH				
	Temp. Coefficient	±0.02% / °C (0 ~ 50°C)				
	Vibration	10 ~ 500Hz, 5G 10min. / 1cycle, period for 60min. each along X, Y, Z axes Compliance to IEC 68-2-6, IEC 68-2-64				
Safety & EMC	Safety Standards	Certified UL 60950-1; EN 60950-1				
	Withstand Voltage	Note.7	I/P-O/P: 3KVAC (4242VDC), I/P-FG: 1.5KVAC (2121VDC), O/P-FG: 0.5KVAC (707VDC), 1min			
	Isolation Resistance	I/P-O/P, I/P-FG, O/P-FG: 100M Ohms / 500VDC				
	EMI Conduction & Radiation	Certified EN 55022; EN 61000-6-3				
	Harmonic Current	Certified EN 61000-3-2; EN 61000-3-3				
	EMS Immunity	Note.6	Certified EN 55024; EN 61204-3, EN 61000-6-1, IEC 61000-4-2, 3, 4, 5, 6, 8, 11			
Others	MTBF	142.8K HRS Certified MIL-HDBK-217F				
	Cooling	Load and temperature control fan				
	Dimension (WxHxD)	127x40.9x283 mm / 5.000x1.610x11.142 inch				
	Packing	2.1kg; 9pcs / 19.9kg / 1.86CUFT				

Note

1. All parameters NOT specially mentioned are measured at 230VAC input, rated load and 25°C of ambient temperature.
2. Ripple & noise are measured at 20MHz of bandwidth by using a 12" twisted pair-wire terminated with a 0.1uF & 47uF parallel capacitor.
3. Tolerance: includes set up tolerance, line regulation and load regulation.
4. De-rating may apply in low input voltage. Please check the de-rating curve for more details.
5. In parallel connection, only one unit will operate if the total output load is less than 5% of the rated load condition.
6. The power supply is considered a component which will be installed into a final equipment. The final equipment must be re-confirmed that it still meets EMC directives.
7. Conduct this test without enclosure.



■ Mechanical Specification:

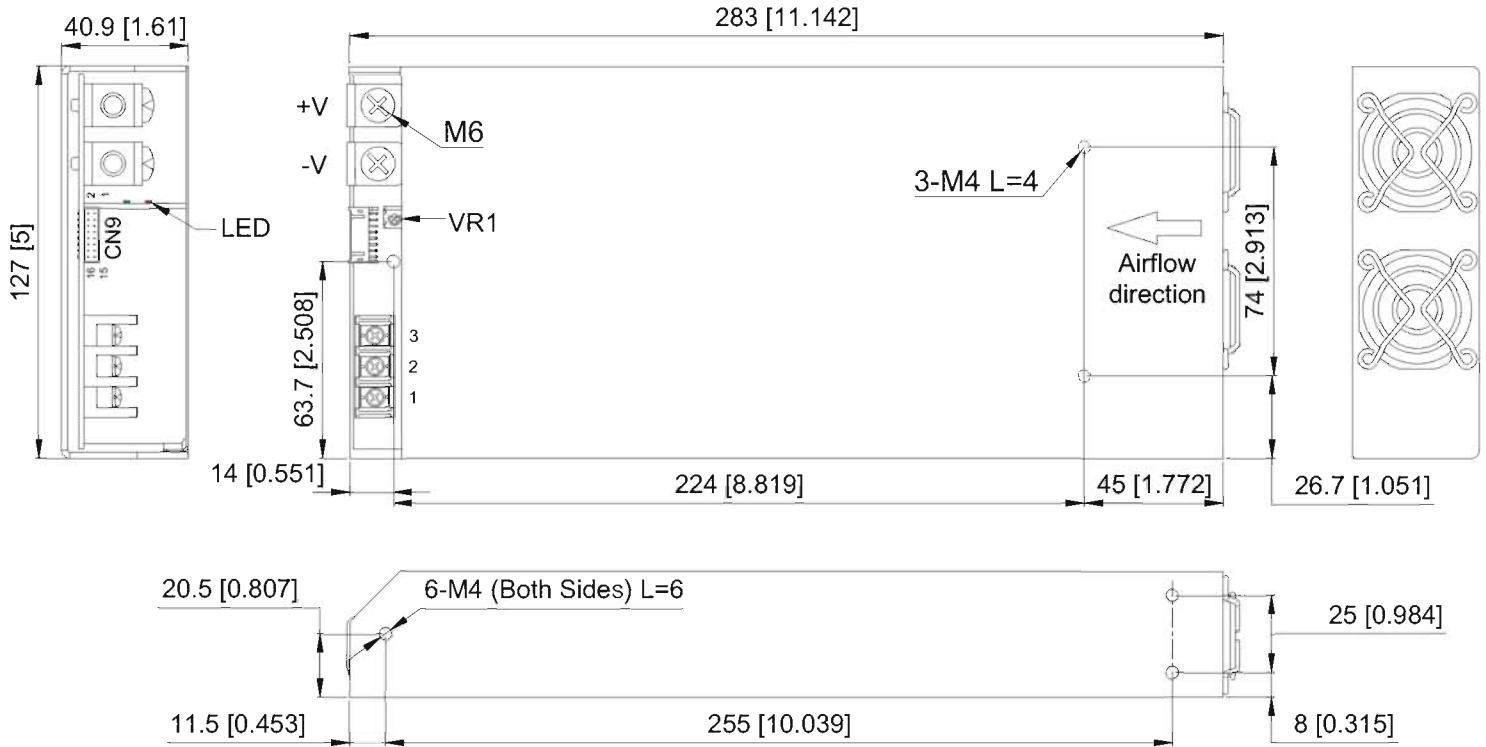

AC Input Terminal Pin No. Assignment

Pin No.	Assignment
1	ACL
2	ACN
3	⏏

Control pin number assignment (CN9): JST S16B-PHDSS or equivalent

Pin No.	Assignment	Pin No.	Assignment	Pin No.	Assignment	Pin No.	Assignment	Mating Housing	Terminal
1	VS+	5	AUX	9	EN-	13	VCI	PHDR-16VS	SPHD-002T-P05
2	VO+	6	AUX	10	GND	14	GND		
3	VS-	7	EN+	11	P.OK	15	PAR		
4	VO-	8	GND	12	GND	16	ACI		

■ Function Description of CN9:

Pin No.	Function	Description
1	VS+	Remote voltage sense (+)
2	VO+	Local output voltage sense (+)
3	VS-	Remote voltage sense (-)
4	VO-	Local output voltage sense (-)
5,6	AUX	+5V / 0.5A Auxiliary power
7	EN+	Remote ON/OFF (+)
8,10,12,14	GND	Ground
9	EN-	Remote ON/OFF (-)
11	P.OK	Power OK
13	VCI	V Program
15	PAR	Parallel operation current share
16	ACI	I Program



■ **LED Status:**

Green LED	LED Signal	Status
Solid		Power OK
Slow Blink		Power Standby
Red LED	LED Signal	Status
Fast Blink		Over Voltage Protection (OVP)
Solid		Over Load Protection (OLP)
		Output Shorted Circuit Protection (SCP)
		Under Voltage Protection (UVP)
Slow Blink		Over Temperature Protection (OTP)
Intermittent Blink		Fan Failure
Interlace Blink		Power Failure

■ **De-rating Curve:**

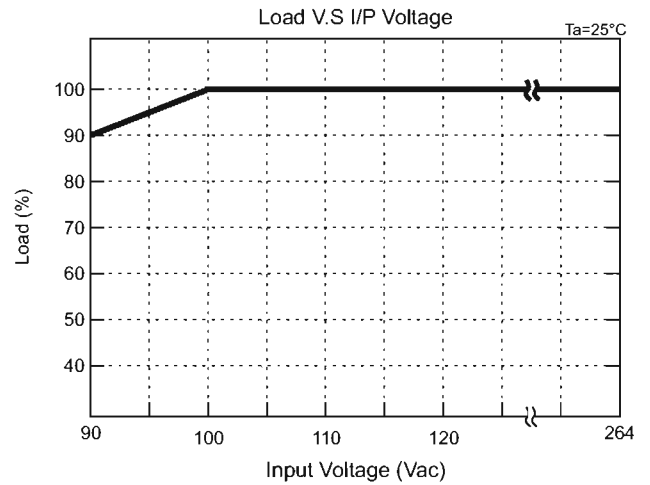
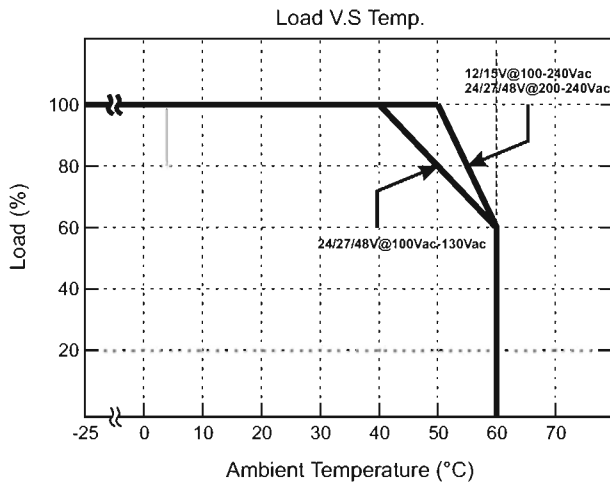

■ **Function Manual:**

1. Output Voltage Trim

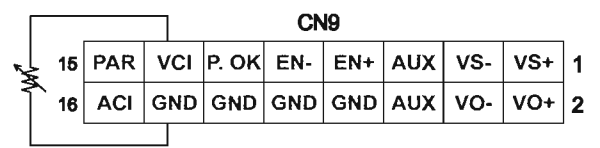
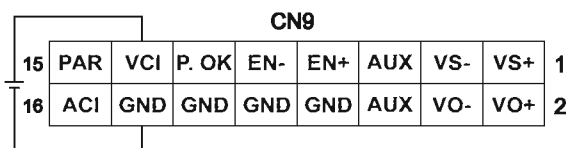
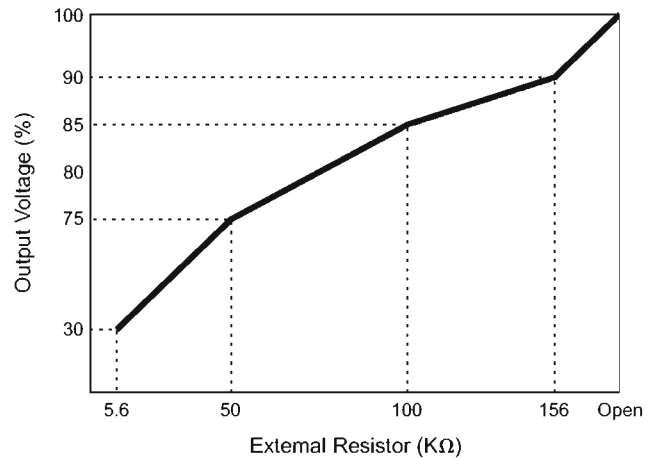
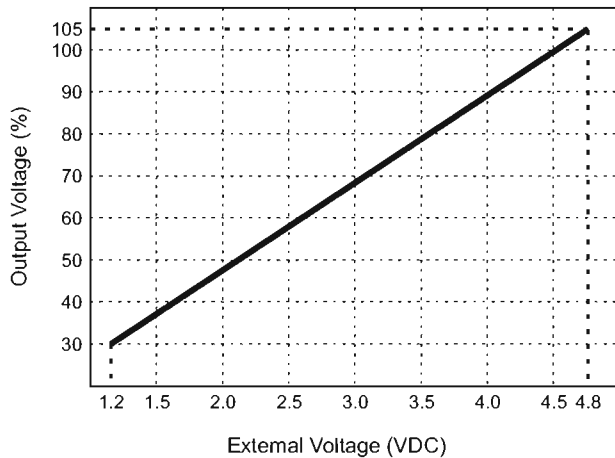

2. Output Current Trim (For Reference Only)

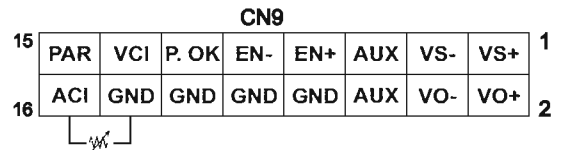
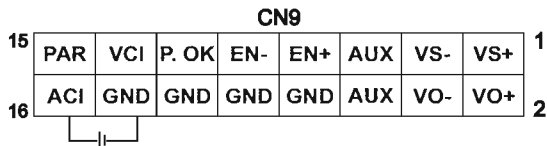
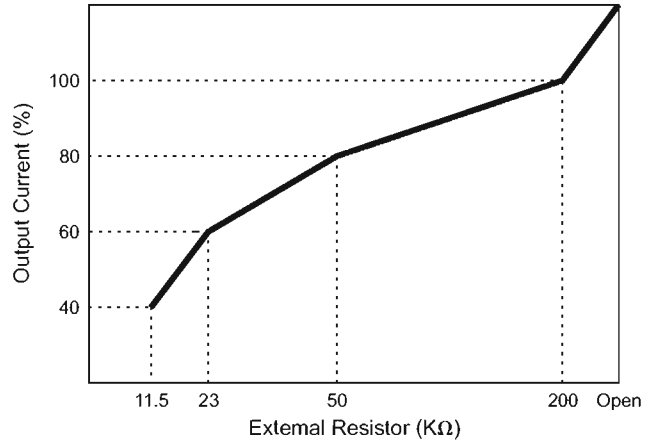
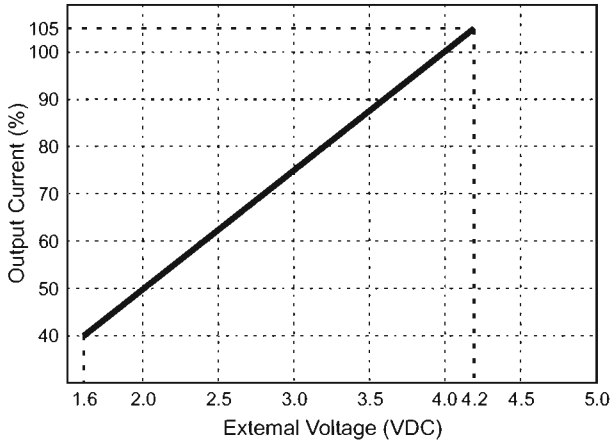

3. Remote ON/OFF

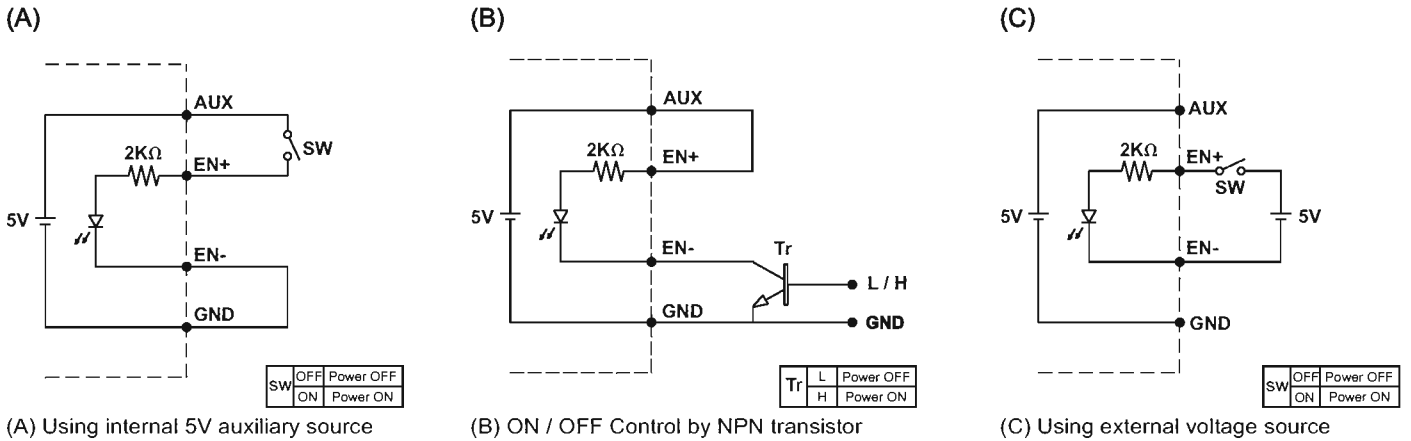

4. Power OK Signal

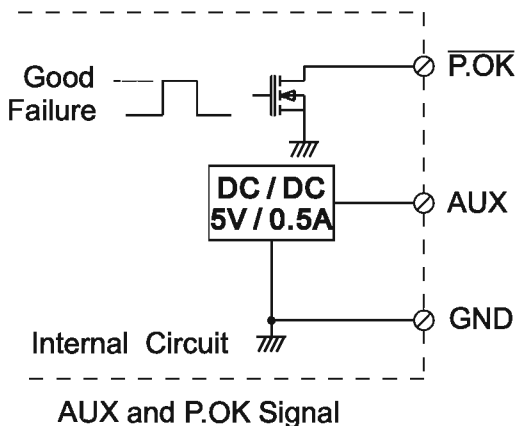

*Place an additional capacitor to have a better performance of auxiliary power operation.
 *The grounding of "AUX" power should be connected to "GND" port. If "V-" is connected as Grounding, make sure to short the GND and V- ports.

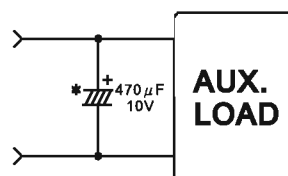



5. Remote Sense

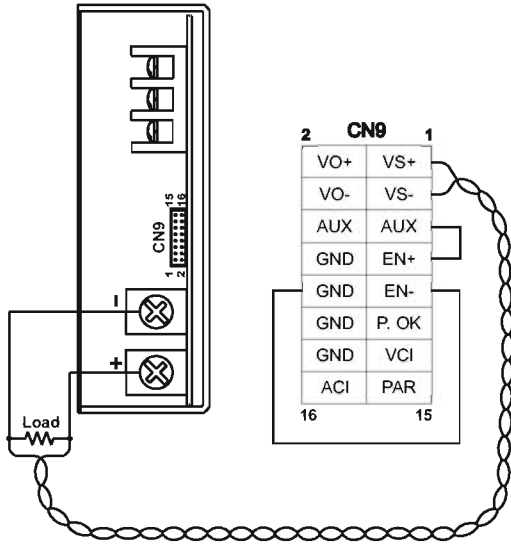

6. Local Sense

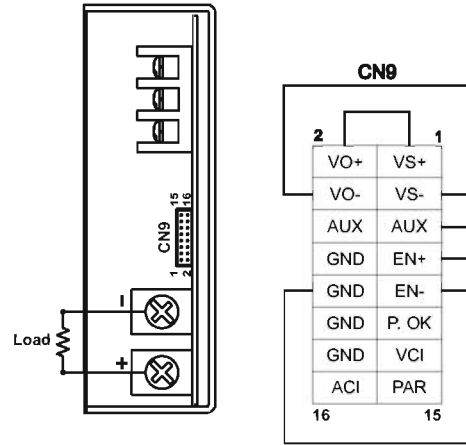

7. Current Sharing with Remote Sensing

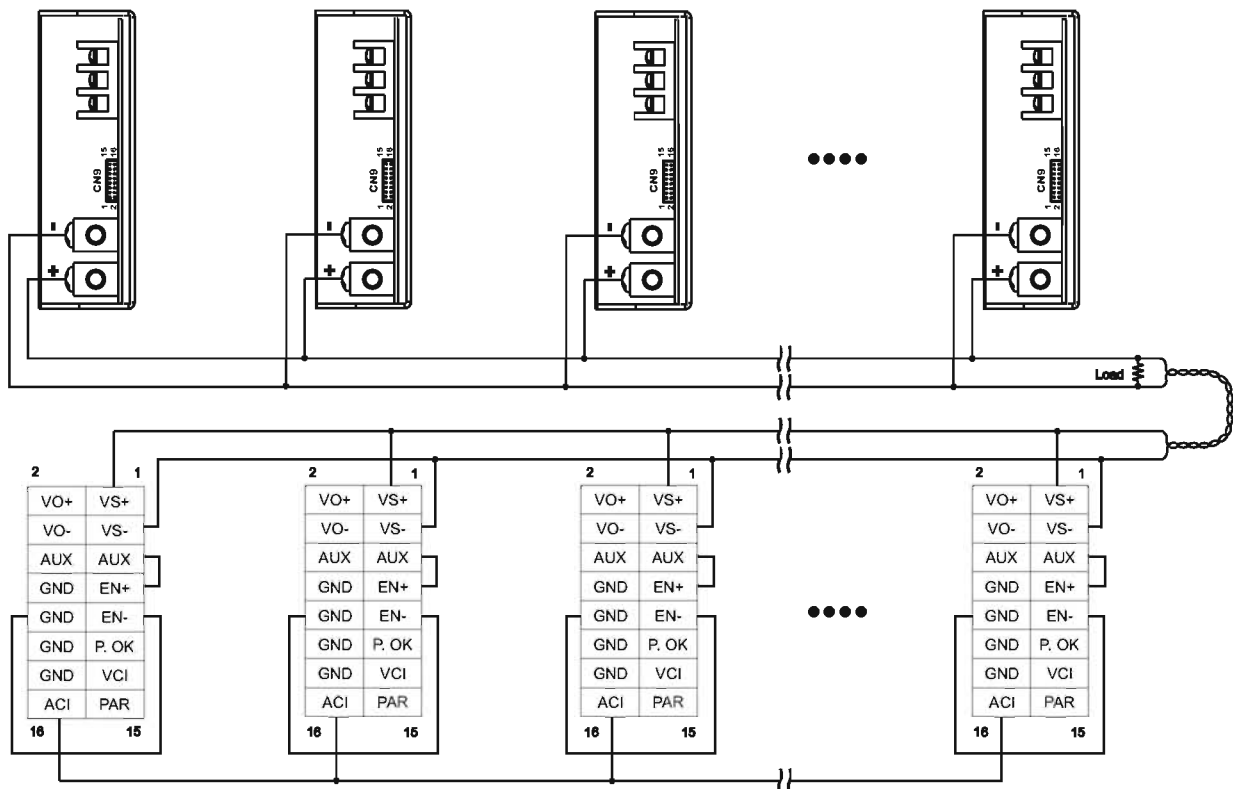

8. Current Sharing with Local Sensing

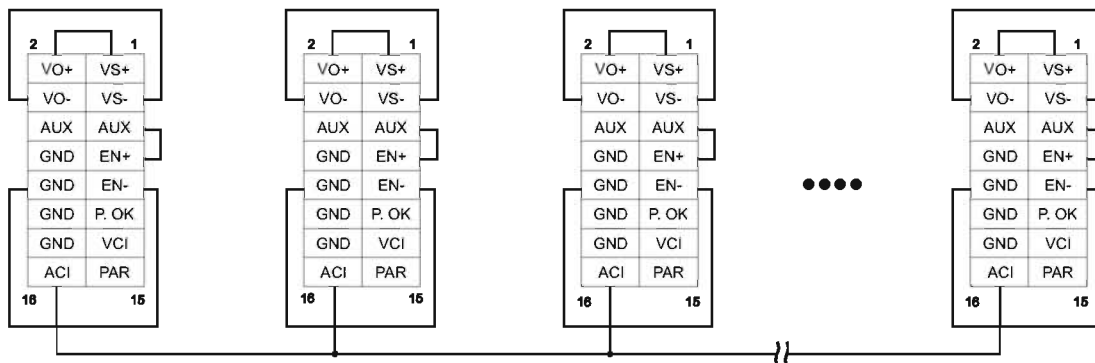



■ **Installation Instruction:**

1. Mounting Directions

1-1 Recommended standard mounting methods:

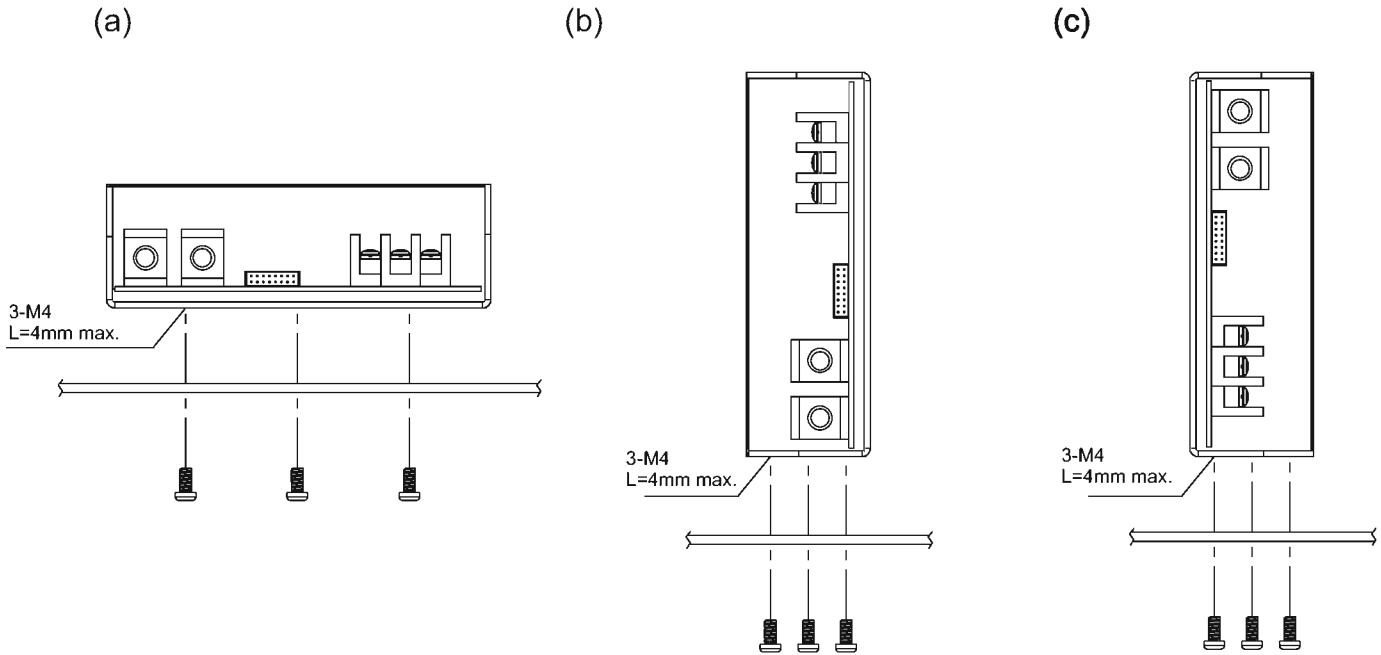

2. Mounting Method

2-1 There are ventilating holes on the front and back side panels, do not obstruct; allow 50mm at least for air flow.

2-2 The Maximum allowable penetration of screw is 4mm. Incomplete threading should not be penetrated.

2-3 Recommended the torque of mounting screw:
M4 screw: 1.27N • m (13.0kgf • cm)

