

## AD-1500

1500W Programmable Digital Power Supply



### ■ Features:

- Universal AC input / Full range (90~264Vac)
- Programmable output voltage and current (0~105%)
- Current sharing at parallel operation
- Constant current limit
- AUX POWER : +5.0V/1.0A
- Built-in OR'ing FETs
- Power OK signal (built –in isolation circuit)
- Remote on/off function
- Intelligent GUI to set and monitoring parameter
- Protection: OVP,OCP,OLP,OTP, Fan failure
- Support Parallel operation via CANBUS (built –in isolation circuit, A23, A24 Version)

### ■ Model Naming Rule: AD-1500-XX-①②③

AD : Product Series      1500 : Wattage      XX : Output voltage      ①②③ : can be A23, A24, C11 or D11

#### Hardware (Interface changeable):

**A23 & A24** : RS-485 Support parallel connection with built-in communication isolation circuit

**C11** : Single unit only

**D11** : Ethernet

#### Communication protocol :

**A23** : Cotek STD protocol (RS-485), and Meet PMBus

**A24** : MODBUS & Meet PMBUS

**C11** : Cotek STD protocol (RS-485)

**D11** : ARP, Device Search Utility (DSU), DHCP Client, IPv4, SNMP, TCP, UDP, ICMP

		AD-1500-120	AD-1500-150	AD-1500-250	AD-1500-400
<b>Output</b>	DC Voltage Rated	120V	150V	250V	400V
	Rated Current	12.5A	10.0A	6.0A	3.75A
	Current Range	0 ~ 12.5A	0 ~ 10.0A	0 ~ 6.0A	0 ~ 3.75A
	Voltage Range	0~105% vs. rated			
	Rated Power	1500W	1500W	1500W	1500W
	Ripple & Noise (Max.)	1200mVp-p	1500mVp-p	2500mVp-p	4000mVp-p
	Voltage Adj. Range	±5.0% Typical adjustment			
	Voltage Tolerance	±2.0% (rate output voltage of single unit)			
	Current Tolerance	±3.0% (rate output current of single unit)			
	Line Regulation	±1.0%			
	Load Regulation	±1.0%			
	Setup, Rise Time	1300ms, 200ms at full load (230V ac)			
	Hold Up Time (Typ.)	14ms / 230VAC at full load			
	<b>Input</b>	Voltage Range (Note. 4)	90 ~ 264VAC, 250~370VDC *		
Frequency Range		47 ~ 63Hz			
Power Factor (Typ.)		0.95 / 230VAC, 0.99 / 115VAC at full load			
Efficiency (Typ.)		92%			
AC Current (Typ.)		18A / 115VAC, 9A / 230VAC			
Inrush Current (Typ.)		30A / 115VAC, 45A / 230VAC (cold start)			
Leakage Current		< 3.5mA / 240VAC			

		AD-1500-120	AD-1500-150	AD-1500-250	AD-1500-400
<b>Protection</b>	Over Load	105% rated output power	Protection type: Constant current limit		
	Over Voltage	Programmable OVP, 120 ± 7% Vout.	Protection type: Latch-style (Recovery after reset AC power ON or inhibit)		
	Over Temperature	Detect on NTC, Protection type: Auto recovery after temperature goes down			
<b>Function</b>	Auxiliary Power	+5.0V / 1.0A			
	Remote ON / OFF Control	By external switch / communication			
	Power OK Signal	Open drain signal low when PSU turns on, Max. sink current: 20mA, Max. drain voltage: 40V			
	Output Voltage Trim	Adjustment of output voltage is between 0% ~ 105% of rated output			
	Output Current Trim	Adjustment of output current is between 0% ~ 105% of rated output			
	Parallel	Current sharing via CANBUS			
<b>Environment</b>	Working Temp.	-25 ~ +60°C (Refer to load de-rating curve)			
	Working Humidity	20 ~ 90% RH non-condensing			
	Storage Temp. & Humidity	-40 ~ +85°C, 10 ~ 95% RH			
	Temp. Coefficient	±0.02% / °C (0 ~ 50°C)			
	Vibration	10 ~ 500Hz, 2G 10min. / 1cycle, period for 60min. each along X, Y, Z axes Compliance to IEC 68-2-6, IEC 68-2-64			
<b>Safety &amp; EMC</b>	Safety Standards	UL 62368-1; EN 62368-1			
	Withstand Voltage (Note. 7)	I/P-O/P: 3KVAC (4242VDC), I/P-FG: 1.5KVAC (2121VDC), O/P-FG: 0.5KVAC (707VDC)			
	Isolation Resistance	I/P-O/P, I/P-FG, O/P-FG: 100M Ohms / 500VDC			
	EMI Conduction & Radiation	EN 55032; EN 61204-3; EN 61000-6-3			
	Power Harmonic & Voltage Fluctuation and Flicker	EN 61000-3-2; EN 61000-3-3			
	EMS Immunity (Note. 6)	EN55035: 2017 / A11: 2020 ; IEC 61000-4-2,3,4,5,6,8,11			
	<b>Others</b>	Cooling	Load and temperature control fan		
Dimension (WxHxD)		127.8 x 63.9 x 296.3 mm / 5.03 x 2.52 x 11.67 inch			
Packing		2.6kg; 6pcs / 16.6kg / 1.86 CUFT			

\*Note:

- All parameters NOT specially mentioned are measured at 230VAC input, rated load and 25°C of ambient temperature.
- Ripple & noise are measured at 20MHz of bandwidth by using a 12" twisted pair-wire terminated with a 0.1uF & 47uF parallel capacitor.
- Tolerance: includes setup time tolerance, line regulation and load regulation.
- De-rating may apply in low input voltage. Please check the de-rating curve for more details.
- In parallel connection, only one unit will operate if the total output load is less than 10% of the rated power.
- The power supply is considered a component which will be installed into a final equipment. The final equipment must be re-confirmed that it still meets EMC directives.
- This test is done without enclosure: I/P-O/P 4242VDC. If with enclosure: I/P-O/P 2121VDC, I/P-FG: 2121VDC, O/P-FG: 707VDC

## ■ De-rating Curve

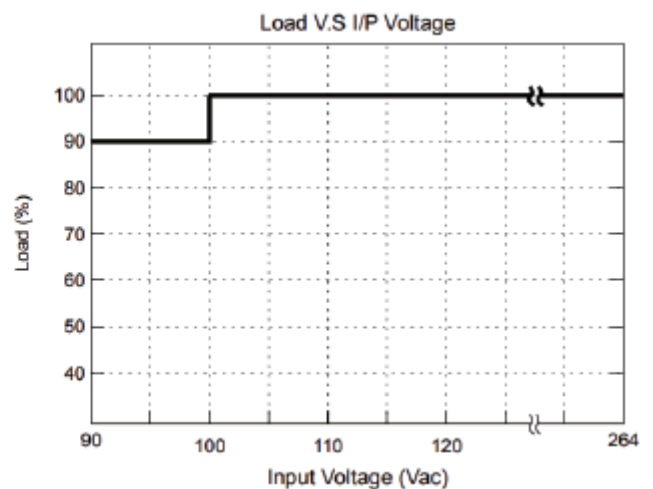
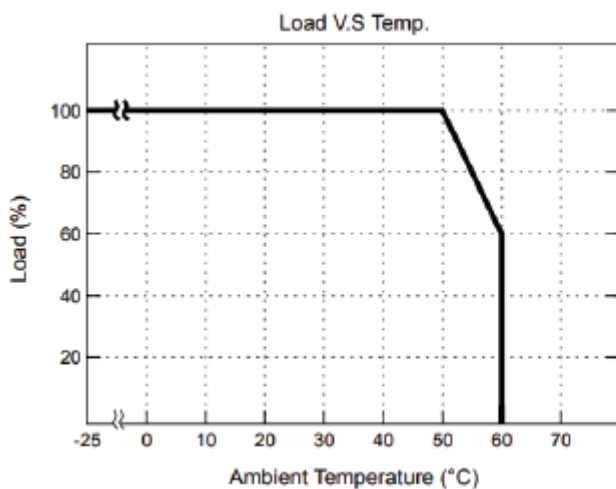

■ **REMOTE ON/OFF**

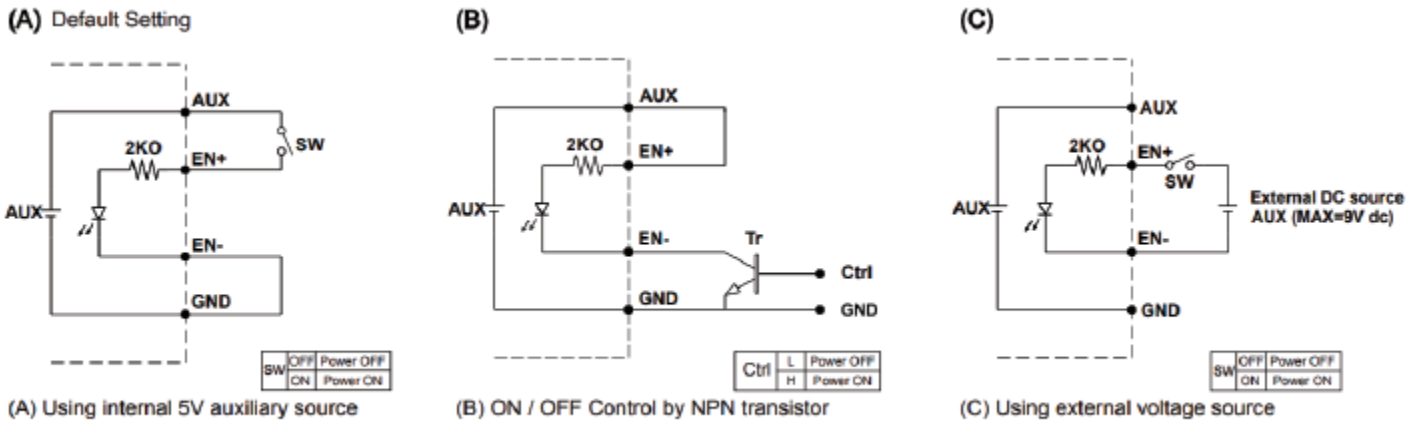

\*GND shown in above diagram is referring to the GND of the interchangeable interface card, not the Grounding from main power(NEG-).\*

■ **Power OK Signal & Auxiliary Power Setting**

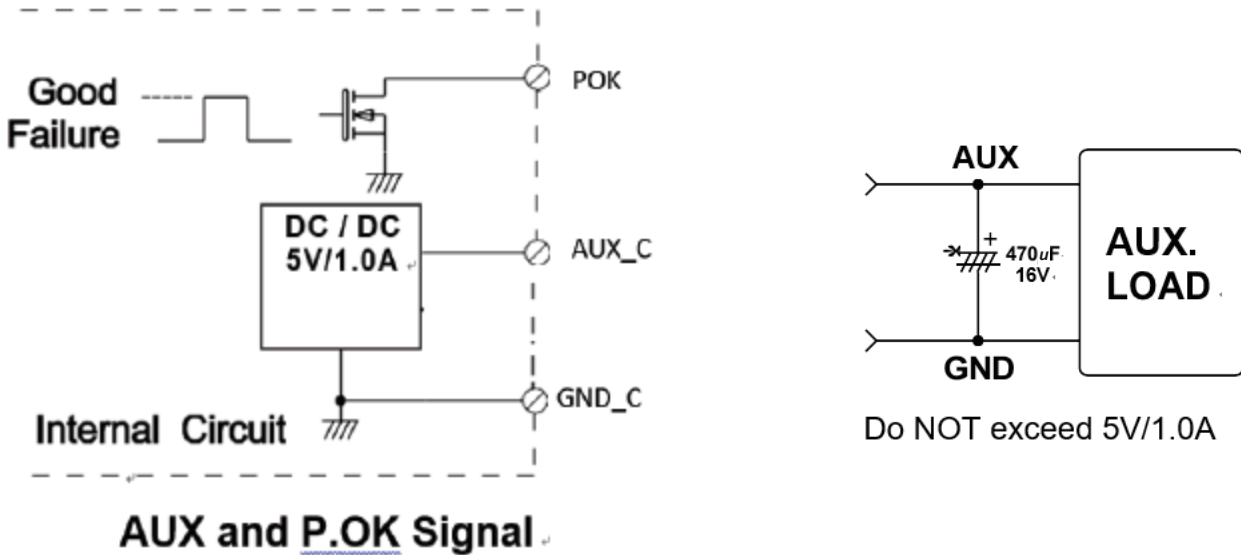

Open drain signal low when PSU turns on, Max. P.OK sink current: 20mA, Max. drain voltage: 40V

To ensure better auxiliary power operation performance, make sure to install an additional capacitor per diag. as shown above

**A23 and A24**

\*The grounding of "AUX" power and P.OK signal should be connected to GND\_C port. GND\_C & VO- are used for isolation with different voltage level.\*

**C-11**

\*GND shown in above diagram is referring to the GND of the AD-1500 Chassis, not the Grounding from the main power(NEG-)\*

## ■ Function LED

LED	LED Signal	Status
Solid(Green)		Power OK (Local mode)
Solid(Orange)		Power OK (Remote mode)
Slow Blink(Green)		Power Standby (Local mode)
Slow Blink(Orange)		Power Standby (Remote mode)
Fast Blink(Red)		Over Voltage Protection ( OVP)
Solid(Red)		Over Load Protection ( OLP)
Slow Blink(Red)		Over Temperature Protection ( OTP)
Intermittent Blink(Red)		Fan Failure
Interlace Blink (Red)		Power Failure
Slow Blink (Red)		AC Failure

## ■ Interface card (Changeable)

1. A23&A24 (Support Parallel Connection)

2. C11 (Single unit)

3. D11 (Ethernet)

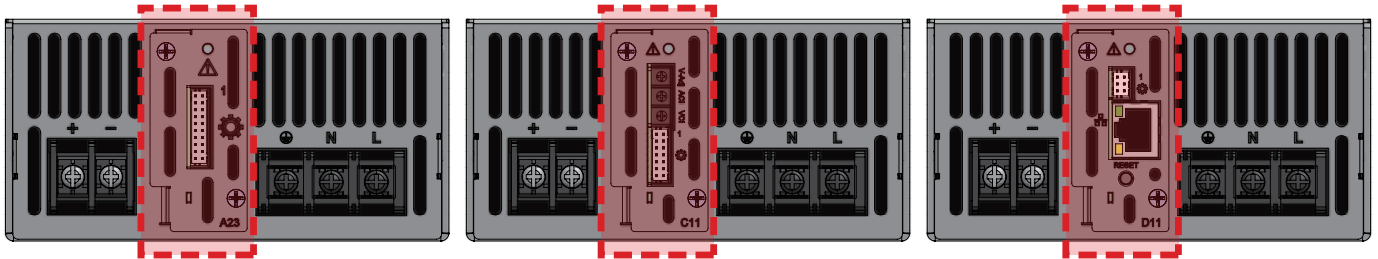

### PIN Function Description:

1. A23 & A24 (Support Parallel Connection)

Pin No.	Function	Description	Pin No.	Function	Description	Mating Housing / Contact	
1	X	Reserve	2	X	Reserve	JST PHDR-20VS or equivalent	JST SPHD-002T-P0.5 or equivalent
3	X	Reserve	4	X	Reserve		
5	EN+	Inhibit ON/OFF (+)	6	AUX	5V / 1A Auxiliary power		
7	EN-	Inhibit ON/OFF (-)	8	GND_C	Communication Ground		
9	H_TERM	CAN Termination	10	L_TERM	CAN Termination		
11	CANH	Dedicated in parallel (CAN BUS High-level)	12	CANL	Dedicated in parallel (CAN BUS Low-level)		
13	SCL	Serial Clock used in the I <sup>2</sup> C interface	14	SDA	Serial Data used in the I <sup>2</sup> C interface		
15	POK	Power OK (40V / 20mA / <0.5W Open collector)	16	GND_C	Communication Ground		
17	RS485-A	Driver Output / Receiver Input Non-inverting	18	RS485-B	Driver Output / Receiver Input Inverting		
19	AUX_C	5V / 1A Auxiliary power	20	GND_C	Communication Ground		

### 2. C11 (Single Unit)

Pin No.	Function	Description	Pin No.	Function	Description	Mating Housing / Contact	
1	X	Reserve	2	X	Reserve	JST PHDR-14VS or equivalent	JST SPHD-002T-P0.5 or equivalent
3	ENB+	Inhibit ON/OFF (+)	4	AUX	5V / 1A Auxiliary power		
5	ENB-	Inhibit ON/OFF (-)	6	GND	Communication Ground		
7	A_TERM	RS-485 Termination	8	B_TERM	RS-485 Termination		
9	485_A	Driver Output / Receiver Input Non-inverting	10	485_B	Driver Output/Receiver Input Inverting		
11	POK	Power OK (40V / 20mA / <0.5W Open collector)	12	GND	Communication Ground		
13	AUX	5V / 1A Auxiliary power	14	GND	Communication Ground		

### 3. Ethernet (Coming soon!)

Pin No.	Function	Description	Pin No.	Function	Description	Mating Housing / Contact	
1	H_TERM +	Remote sense (+)	2	L_TERM	CAN Termination	JST PHDR-6VS or equivalent	JST SPHD-002T-P0.5 or equivalent
3	CANH	Dedicated in parallel (CAN BUS High-level)	4	CANL	Dedicated in parallel (CAN BUS Low-level)		
5	GND_C	Communication Ground	6	GND_C	Communication Ground		

### ■ Mechanical Drawings : Unit: mm [inch]

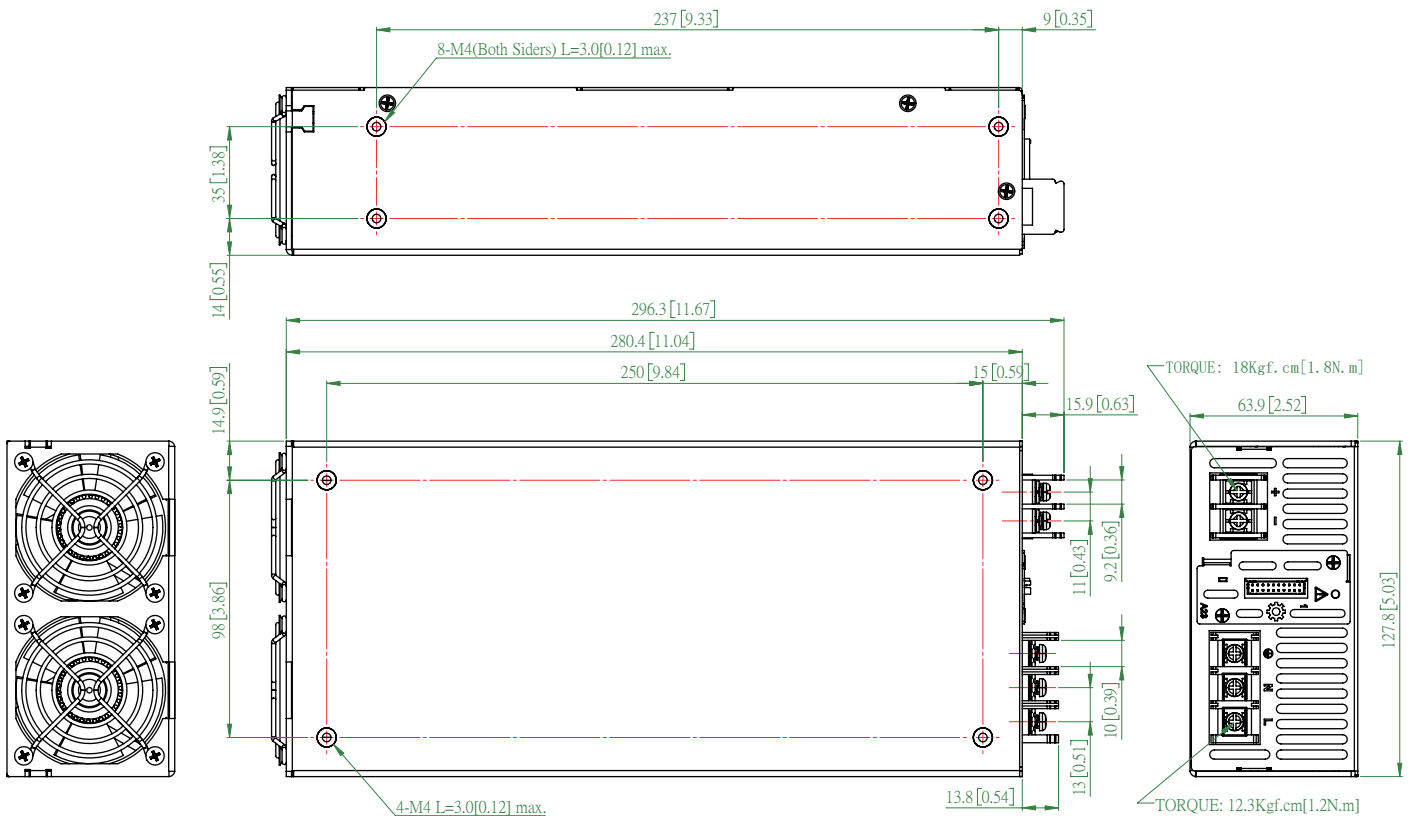

## Installation Instruction

### 1. Mounting Directions

1-1 Recommended standard mounting methods:

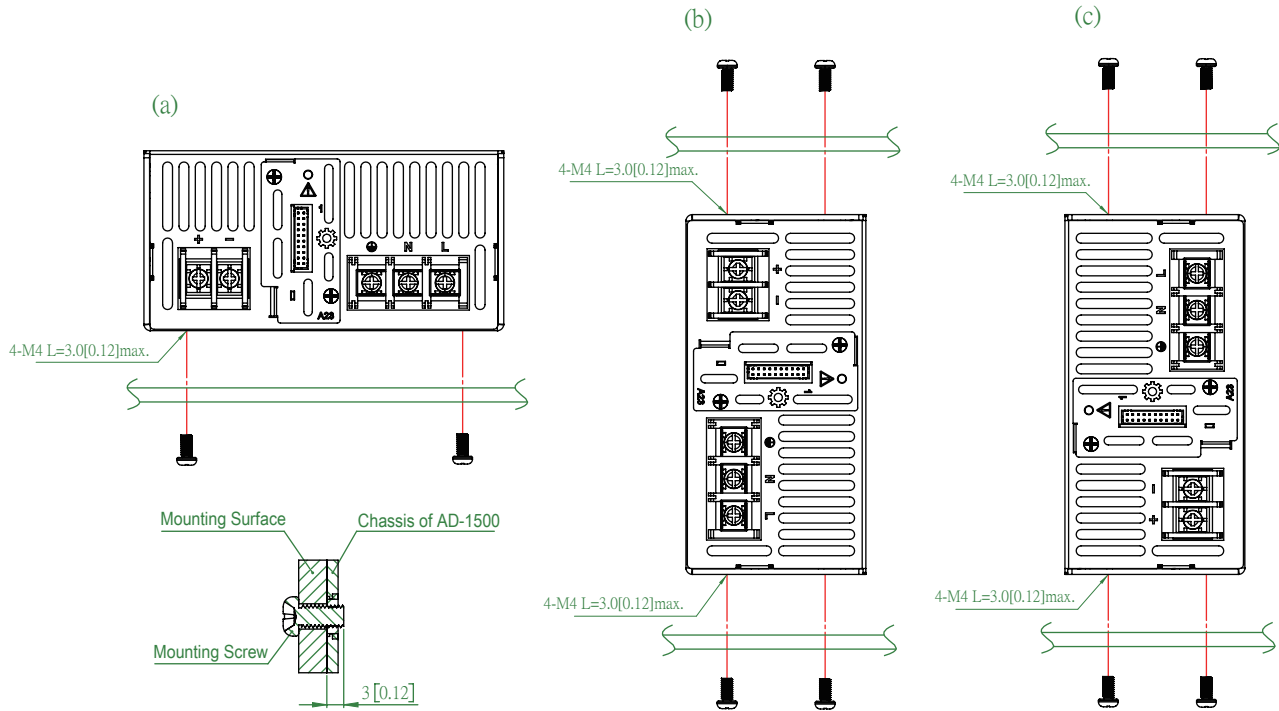

Recommended screw length is measured from the power supply surface

### 2. Mounting Method

2-1 There are ventilating holes on the front and back side panels, do not obstruct; allow 50mm at least for air flow.

2-2 Recommended the torque of mounting screw: M4 screw: 1.27Nm (13.0kgf cm)

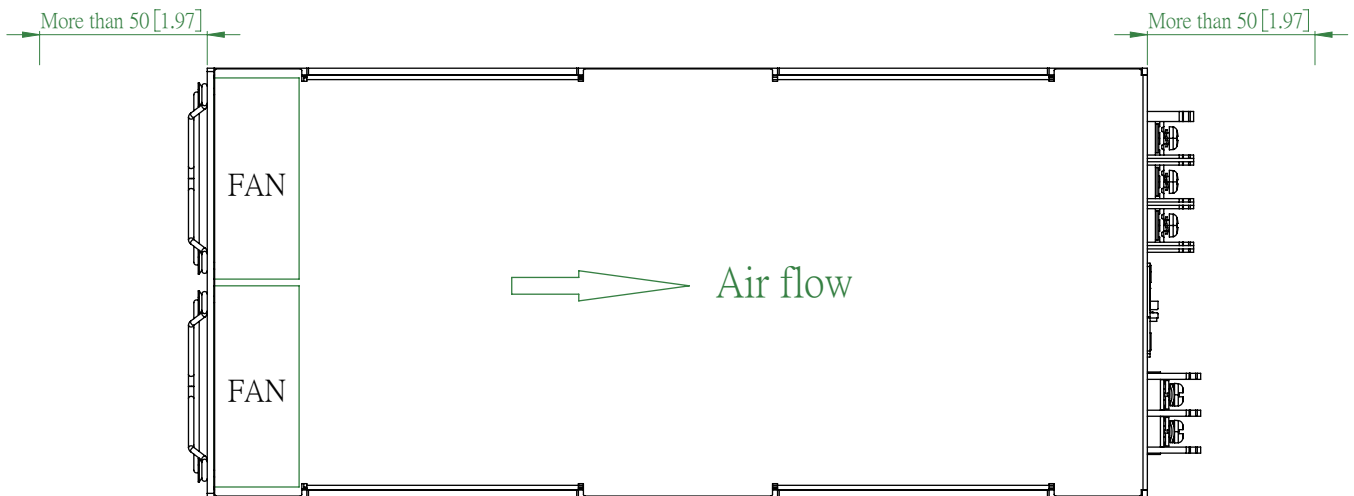

Distributed by: KEPCO, INC. • 131-38 Sanford Ave. • Flushing NY 11355 • Tel: (718) 461-7000 • FAX: (718) 767-1102  
 Email: [hq@kepcopower.com](mailto:hq@kepcopower.com) • [www.kepcopower.com](http://www.kepcopower.com)