

# INSTRUCTION MANUAL

## PTR SERIES

### POWER SUPPLY

#### AUTOMATIC CROSSOVER

KEPCO INC.  
An ISO 9001 Company.

 <b>MODEL PTR SERIES POWER SUPPLY</b>	
ORDER NO.	REV. NO.

**NOTE:** This on-line version of the Technical Manual includes only installation and operating instructions. For the complete manual, please contact Kepco.

©2000, KEPCO, INC.



**KEPCO®**

**THE POWER SUPPLIER™**

KEPCO, INC. 1 131-38 SANFORD AVENUE 1 FLUSHING, NY. 11352 U.S.A. 1 TEL (718) 461-7000 1 FAX (718) 767-1102  
email: [hq@kepcopower.com](mailto:hq@kepcopower.com) 1 World Wide Web: <http://www.kepcopower.com>



## TABLE OF CONTENTS

PARAGRAPH		PAGE
<b>SECTION I – INTRODUCTION</b>		
1-1	Scope of Manual . . . . .	1-1
1-3	General Description . . . . .	1-1
1-8	Specifications, General . . . . .	1-1
1-9	Features . . . . .	1-2
1-10	Specifications, Performance . . . . .	1-2
1-11	Dynamic Specifications . . . . .	1-4
1-12	Specifications for Optional Overvoltage Crowbar . . . . .	1-4
1-13	Mechanical Specifications . . . . .	1-4
1-14	Accessories . . . . .	1-4
<b>SECTION II – INSTALLATION</b>		
2-1	Unpacking and Inspection . . . . .	2-1
2-3	Terminations . . . . .	2-1
2-6	A-C Power Requirements . . . . .	2-2
2-8	Grounding . . . . .	2-2
2-10	Operational Check . . . . .	2-3
<b>SECTION III – OPERATION</b>		
3-1	General . . . . .	3-1
3-3	A-C (Safety) Grounding . . . . .	3-1
3-6	D-C (Signal) Grounding . . . . .	3-1
3-12	Power Supply/Load Interface . . . . .	3-2
3-16	Load Connection, General . . . . .	3-3
3-19	Load Connection, Method I (Local, Noncritical Loads) . . . . .	3-3
3-21	Load Connection, Method II (Remote Error Sensing) . . . . .	3-4
3-24	Load Connection, Method III (External Load Capacitor) . . . . .	3-4
3-27	<b>STANDARD POWER SUPPLY OPERATION, STABILIZED OUTPUT VOLTAGE</b> . . . . .	3-5
3-31	The PTR Power Supply as a Current Stabilizer . . . . .	3-5
3-36	<b>STANDARD POWER SUPPLY OPERATION, STABILIZED OUTPUT CURRENT</b> . . . . .	3-6
3-40	<b>THE CONTROL OF SMALL OUTPUT CURRENTS WITH THE PTR</b> . . . . .	3-8
3-42	External Current Sensing and Resistance Control . . . . .	3-8
3-50	External Current Sensing and Voltage Control . . . . .	3-11
3-58	Current Control by Voltage (Without Sensing Resistor) . . . . .	3-12
3-64	<b>PRECISION OUTPUT VOLTAGE PROGRAMMING</b> . . . . .	3-14
3-70	Precision Resistance Programming . . . . .	3-15
3-74	Conductance Programming . . . . .	3-16
3-79	Voltage Programming . . . . .	3-17
3-85	<b>SERIES CONNECTION WITH PTR POWER SUPPLIES</b> . . . . .	3-19
3-92	<b>PARALLEL OPERATION OF PTR POWER SUPPLIES</b> . . . . .	3-21
3-98	Voltage Programming With the Noninverting Input . . . . .	3-24
3-102	Flag Signal . . . . .	3-25/3-26
<b>SECTION IV – THEORY OF OPERATION</b>		
4-1	Simplified Diagram Discussion . . . . .	4-1
4-4	Circuit Description . . . . .	4-1

**TABLE OF CONTENTS**  
(continued)

<b>PARAGRAPH</b>		<b>PAGE</b>
 <b>SECTION V – MAINTENANCE</b>		
5-1	General . . . . .	5-1
5-3	Disassembly and Reassembly . . . . .	5-1
5-5	Internal Adjustment Procedures . . . . .	5-1
5-9	<b>INSTALLATION OF OPTIONAL CONTROLS</b> . . . . .	5-1
5-13	<b>TROUBLE SHOOTING</b> . . . . .	5-3
5-17	Power Supply Measurements . . . . .	5-4
 <b>SECTION VI – PARTS LIST AND DIAGRAMS</b>		
6-1	General . . . . .	6-1/6-2
6-3	Ordering Information . . . . .	6-1/6-2

**LIST OF TABLES**

<b>TABLE</b>		<b>PAGE</b>
1-1	Output Specifications and A-C Input Current Requirements . . . . .	1-2
1-2	Electrical Performance Specifications . . . . .	1-3
2-1	Rear Terminal Functions . . . . .	2-1
2-2	Internal Controls and their Functions . . . . .	2-2
3-1	Values for External Sensing and Control Circuits . . . . .	3-9

## LIST OF ILLUSTRATIONS

FIGURE		PAGE
1-1	Kepeco "PTR" Automatic Crossover Power Supply Module . . . . .	iv
1-2	Mechanical Outline Drawing . . . . .	1-5/1-6
2-1	Rear Terminations . . . . .	2-1
2-2	Conversion to 230V A-C Operation and Location of Internal Signal Ground . . . . .	2-2
2-3	Connections for Operation Checkout . . . . .	2-3
2-4	Overvoltage Crowbar Setup Circuit . . . . .	2-4
3-1	Illustration of "Safety" and "Signal" Grounding . . . . .	3-1
3-2	Typical Output Impedance versus Frequency Plot . . . . .	3-2
3-3	Load Connection, Method I . . . . .	3-3
3-4	Load Connection, Method II . . . . .	3-4
3-5	Load Connection, Method III . . . . .	3-5
3-6	Operating Characteristic, Voltage versus Current Stabilizer . . . . .	3-6
3-7	Connections for Internal Current Mode Operation, External Resistance Control . . . . .	3-7
3-8	Connections for Internal Current Mode Operation, External Voltage Control . . . . .	3-7
3-9	Equivalent Diagram, PTR With External Sensing and Resistance Control . . . . .	3-8
3-10	Connections for External Sensing and Resistance Control . . . . .	3-10
3-11	Equivalent Diagram, PTR With External Sensing and Voltage Control . . . . .	3-11
3-12	Connections for External Sensing and Voltage Control . . . . .	3-12
3-13	Equivalent Diagram, PTR Current Control Without Sensing Resistor . . . . .	3-12
3-14	Connections for Current Control by Voltage (without "R <sub>S</sub> ") . . . . .	3-13
3-15	Equivalent Diagram, PTR as a Power Amplifier . . . . .	3-14
3-16	Connections for Programming Ratio Calibration . . . . .	3-15
3-17	Programming Ratio, Graph . . . . .	3-16
3-18	Connections for Conductance Programming . . . . .	3-17
3-19	Connections for Programming in the Voltage Mode . . . . .	3-18
3-20	"Automatic" Series Connection . . . . .	3-19
3-21	"Master/Slave" Series Connection . . . . .	3-20
3-22	E <sub>O</sub> /I <sub>O</sub> Characteristics of Two Parallel Power Supplies . . . . .	3-22
3-23	"Automatic" Parallel Connection . . . . .	3-22
3-24	"Master/Slave" Parallel Connection . . . . .	3-23
3-25	Connections for "Noninverting" Programming . . . . .	3-24
3-26	Simplified Diagram, Kepeco PTR Models . . . . .	3-27/3-28
4-1	Simplified Diagram, PTR Power Supplies . . . . .	4-1
5-1	Installation of Optional Components . . . . .	5-2
5-2	Output Effect Measurements, Voltage Mode . . . . .	5-5/5-6
5-3	Output Effect Measurements, Current Mode . . . . .	5-5/5-6
5-4	Disassembly/Re-assembly of PTR Module . . . . .	5-7/5-8
6-1	Component Location, Main Chassis . . . . .	6-11/6-12
6-2	Component Location, Assembly A3 . . . . .	6-13/6-14
6-3	Component Location, Assembly A1 . . . . .	6-15/6-16
6-4	Component Location, Assembly A4 (Models With Option "VP" Only) . . . . .	6-15/6-16
6-5	Main Schematic Diagram . . . . .	6-17/6-18

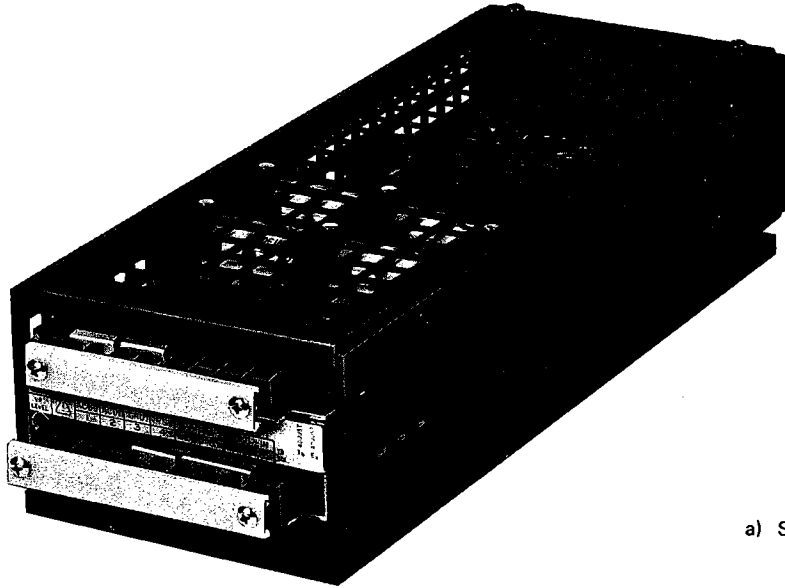

a) SINGLE PTR MODULE.

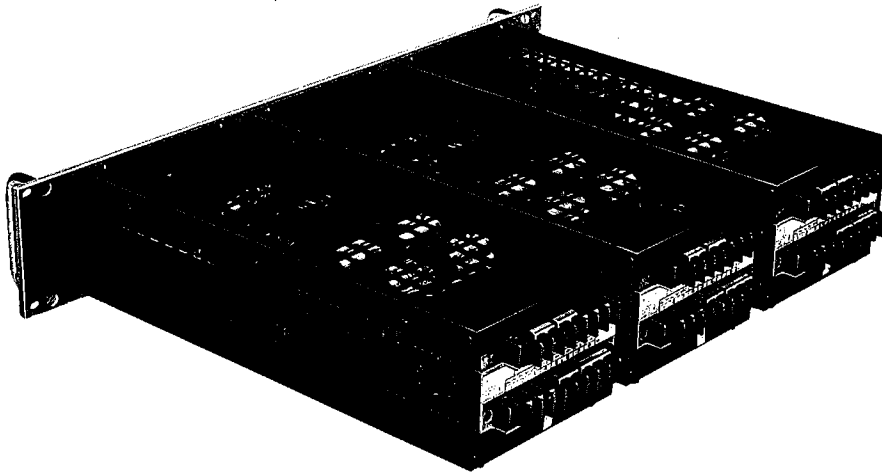

b) THREE PTR MODULES MOUNTED ON  
RA 33-3 RACK ADAPTER.

FIG. 1-1 KEPCO "PTR" AUTOMATIC CROSSOVER  
POWER SUPPLY MODULE.

## SECTION I – INTRODUCTION

### 1-1 SCOPE OF MANUAL

- 1-2 This manual contains instructions for the installation, operation and maintenance of the "PTR" group of modular power supplies manufactured by Kepco, Inc., Flushing, New York.

### 1-3 GENERAL DESCRIPTION (Refer to FIG. 1-1)

- 1-4 The Kepco PTR group consists of a series of modular d-c power supplies with identical outside dimensions and electrical specifications, except for the output ratings (refer to Table 1-1). PTR Power Supply modules can be directly installed by Original Equipment Manufacturers (OEM's), or they can be used in a rack installation with Kepco's mounting hardware as described in par. 1-14 below.
- 1-5 The PTR Power Supply can deliver stabilized *output voltage* or stabilized *output current*, with *automatic crossover* between the two operating modes. The crossover is indicated by a "*flag signal*," available at the barrier-strip terminals. The PTR Power Supply is completely *short-circuit proof* and can be *fully programmed* by external resistance, or by voltage or current signals. Barrier-strip terminals are provided for the following functions:
- A-C Source Input.
  - D-C Output.
  - Voltage Control.
  - Remote Current Control.
  - Error Sensing.
  - Input for Inverting or Noninverting Voltage Programming.
  - Flag Signal Output.
- 1-6 The PTR Power Supply utilizes a fully dissipative NPN silicon power transistor as the series regulator. The series regulator is driven by monolithic, integrated circuit amplifiers. Together with extremely stable voltage and current reference sources, they provide the basis for the exceptional performance of the PTR in the voltage as well as in the current mode of operation.
- 1-7 Built-in options for the PTR are designated by an alphabetical or numerical suffix to their model number and include the following:
- MODELS WITH SUFFIX "20000." Contain internal voltage control rheostat or other special modifications.
  - MODELS WITH SUFFIX "E." Contain "zero" calibrating control.
  - MODELS WITH SUFFIX "R." Contain control current ("I<sub>b</sub> CAL") calibrating control.
  - MODELS WITH SUFFIX "T." Supplied with test report, certifying the following temperature coefficients: 0.005% per °C VOLTAGE MODE, 0.02% per °C CURRENT MODE (internal sensing), 0.01% per °C CURRENT MODE (external sensing).
  - MODELS WITH SUFFIX "VP." Contain factory-installed overvoltage crowbar.

**NOTE:** Options (except "VP" and "T") may be installed by the user. Installation instructions are given in Section V of this manual.

### 1-8 SPECIFICATIONS, GENERAL

- A-C INPUT:** 105 to 125V a-c *or* 210 to 250V a-c, selectable (refer to Section II par. 2-6), 50 to 65 Hz, single phase. Refer to Table 1-1 for the a-c input current requirements. Power factor approx. 0.9.
- AMBIENT OPERATING TEMPERATURE:** (-)20°C to (+)71°C.
- STORAGE TEMPERATURE:** (-)40°C to (+)85°C.
- COOLING:** Convection.
- ISOLATION VOLTAGE:** A maximum of 500 volts (d-c or p-p) can be connected between chassis and either output terminal. The common mode current from output to ground is less than 5 μA rms, 50 μA peak-to-peak at 115V a-c, 60 Hz.

## 1-9 FEATURES

- a) OUTPUT RANGES (See Table 1-1)
  - 1) VOLTAGE MODE: 0–100% of rated voltage. (See option "E.")
  - 2) CURRENT MODE (internally sensed):  
Setting range: 2%  $I_O$  max. to 110%  $I_O$  max.  
Control range (that part of setting range for which the current meets its stabilization specification): 10%  $I_O$  to 100%  $I_O$  max.
  - 3) CURRENT MODE (externally sensed, 1-volt sample, with current feedback to the *voltage* amplifier): 1 mA to 100%  $I_O$  max. Models equipped with option "E" can be controlled from approximately 1 microampere to maximum output current.
- b) MODE FLAG (a d-c signal referred to [+] sense):  
Voltage mode: Flag is  $\leq 0V$  d-c.  
Current mode: Flag is  $\geq 5V$  d-c; source impedance 5 K ohms.
- c) CONTROL/PROGRAMMING
  - 1) Voltage channel: Output voltage is operationally controlled by resistance ratios functioning with either the internal or an external reference, or by a control voltage in the feedback loop, or in the noninverting input. A fixed 6.2V  $\pm 5\%$  reference and 5700-ohm resistor is built-in, giving approximately 1.1 mA control current. A simple external rheostat, therefore, controls the resistance ratio at approximately 900 ohms per volt. Option "R" offers a means for trimming the control current to exactly 1.0 mA to calibrate the control rheostat at 1000 ohms per volt. External signals can be substituted for—or summed with—the internal reference for additional control.
  - 2) Current channel: The current is sampled by an internal resistance. An internal current setting potentiometer is provided. External control can be exercised by an adjustable voltage or by external potentiometer.
- d) OPEN LOOP d-c GAIN (voltage channel):  $\geq 10^6$  volts per volt.
- e) SHORT CIRCUIT PROTECTION: The "crossover" circuit of the PTR permits continuous operation into a short circuit without the aid of fuses, circuit breakers, or relays. Output returns to the operating voltage when the overload is removed.
- f) REMOTE ERROR SENSING: Error sensing terminals enable the PTR to stabilize the output voltage directly at the load by compensating for voltage drops (up to 0.5 volt) across each load supply lead.
- g) SERIES/PARALLEL OPERATION: Series connection of identical units is possible up to the specified isolation voltage limit, provided the necessary precautions are taken (see par. 3-85). PTR supplies can be parallel connected and will share the load by means of their current limiting feature (see par. 3-92).
- h) OVERSHOOT: No output voltage overshoot from turn-on, turn-off or power failure for output settings above 25% maximum rated output voltage. Below 25%, output voltage overshoot is a function of load current and is negligible for loads in excess of 10% of the maximum rated load current.

## 1-10 SPECIFICATIONS, ELECTRICAL PERFORMANCE

- a) Refer to TABLES 1-1 and 1-2.

MODEL	D-C OUTPUT RANGE		OUTPUT IMPEDANCE		MAX. A-C INPUT CURRENT AT 125V A-C
	VOLTS	AMPS	VOLTAGE MODE D-C OHMS + SERIES L	CURRENT MODE <sup>(1)</sup> D-C OHMS + SHUNT C	
PTR 7–5.5	0–7	0–5.5	64 $\mu\Omega$ + 0.5 $\mu H$	90 K $\Omega$ + 1250 $\mu F$	1.4A
PTR 15–3.3	0–15	0–3.3	225 $\mu\Omega$ + 0.5 $\mu H$	150 K $\Omega$ + 800 $\mu F$	1.4A
PTR 21–2.5	0–21	0–2.5	420 $\mu\Omega$ + 0.5 $\mu H$	200 K $\Omega$ + 500 $\mu F$	1.4A
PTR 40–1.4	0–40	0–1.4	1.4 m $\Omega$ + 0.5 $\mu H$	350 K $\Omega$ + 350 $\mu F$	1.4A
PTR 72–0.8	0–72	0–0.8	4.5 m $\Omega$ + 0.5 $\mu H$	625 K $\Omega$ + 300 $\mu F$	1.4A
PTR 100–0.6	0–100	0–0.6	10 m $\Omega$ + 0.5 $\mu H$	840 K $\Omega$ + 100 $\mu F$	1.4A

<sup>(1)</sup>D-C value is for external sensing and feedback; d-c value for internal-sensing mode is  $E_O/5$  mA.

TABLE 1-1 OUTPUT SPECIFICATIONS AND A-C INPUT CURRENT REQUIREMENTS.



NOTE: In this instruction manual Kepco discontinues the use of the specifications entitled "line regulation" and "load regulation" because of the long standing (and misleading) connotation that a power supply regulates the line or the load. Instead, Kepco will follow the NEMA standards for D-C Power Supplies and speak of the "Output Effects, caused by changes in the Influence Quantities." The "Output Effects" are specified either as a percentage change referred to the maximum specified output voltage ( $E_o$ ) or current ( $I_o$ ) or as an absolute change ( $\Delta E_o$ ,  $\Delta I_o$ ) directly in millivolts or milliamperes or both. The "Influence Quantities" are the "Source Variations" (formerly a-c line variations), the changes in load, temperature or time as previously specified. The illustration below will clarify the use of the new terminology.

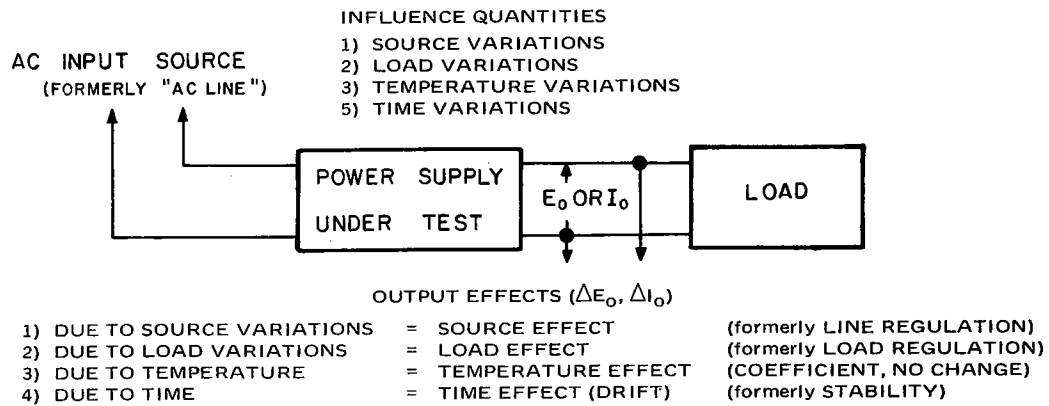

INFLUENCE QUANTITY	OUTPUT EFFECTS VOLTAGE MODE <sup>(2)</sup>	OUTPUT EFFECTS CURRENT MODE		AMPLIFIER OFFSETS <sup>(4)</sup>		VOLTAGE REFERENCE (INTERNAL)
		INTERNAL	EXT. <sup>(3)</sup>	$\Delta E_{io}$	$\Delta I_{io}$	
SOURCE: 105-125/210-250V a-c	<0.001%	<0.005% or 25 $\mu A$ <sup>(1)</sup>	<0.005%	<5 $\mu A$	<1 nA	Fixed
LOAD: No load - full load	<0.005% or 0.1 mV <sup>(1)</sup>	<3.0 mA <sup>(5)</sup>	<0.01%	<100 $\mu V$	<5 nA	6.2V $\pm 5\%$
TIME: 8-hour [drift]	<0.01% or 0.2 mV <sup>(1)</sup>	<0.05% or 0.1 mA <sup>(1)</sup>	<0.02%	<20 $\mu V$	<1 nA	0.0001%
TEMPERATURE: Per $^{\circ}C$	<0.01%	<0.05% or 0.1 mA <sup>(1)</sup>	<0.02%	<20 $\mu V$	<2 nA	0.005%
UNPROGRAMMED OUTPUT DEVIATION: <sup>(6)</sup> (Ripple and noise)	rms	<0.1 mV	<0.5 mA	<0.5 mA	-	-
	p-p <sup>(7)</sup>	<2.0 mV	<2.0 mA	<2.0 mA	-	-

(1) Whichever is greater.

(2) VOLTAGE MODE OUTPUT EFFECTS ( $\Delta E_o$ ) are measured across the ( $\pm$ ) error-sensing terminals, using an external voltage control resistor with a temperature coefficient of 20 parts per million (1000 ohms per volt) and a 1 milliampere control current derived from the internal voltage reference.

(3) Current mode output effects ( $\Delta I_o$ ) are measured across an external measuring resistor. This resistor must be a high quality, wirewound unit, with a wattage at least 10 times the actual power dissipated, have a temperature coefficient of 20 parts per million or better, and drop a sample voltage of 1.0 volt at the measuring current. A resistor built as a 4-terminal network is recommended. In the EXTERNAL CURRENT MODE, current control is exercised with an external 20 ppm feedback resistor. See Section V of this manual for appropriate test circuits.

(4) For special programming applications, the internal reference voltage source may be disconnected and replaced by external input or reference signals.

In these cases, the total (worst case) output variations ( $\Delta E_o$ ) may be calculated, summing the contributions of the voltage amplifier offsets, the external feedback components and the reference or input source errors. The error equation expressing the total output change is given by:

$$\Delta E_o = \pm \Delta E_i \text{ (or } \Delta E_r) (R_f/R_i) \pm \Delta E_{io} (1 + R_f/R_i) \pm \Delta I_{io} R_f.$$

Where:

- $\Delta E_i$  = Variations of the input (programming) voltage source.
- $\Delta E_o$  = Total (worst case) output voltage change.
- $\Delta E_{io}$ ,  $\Delta I_{io}$  = Voltage amplifier offset variations as tabulated.
- $\Delta E_r$  = Variations of the internal reference source as tabulated.
- $R_f$  = External feedback resistance.
- $R_i$  = External input resistance.

(5) 5 mA on models with suffix "VP".

(6) One output terminal grounded, or connected so that the common mode current does not flow through the load (Voltage Mode) or through the sensing resistor (Current Mode).

(7) 20 Hz to 10 MHz.

TABLE 1-2 ELECTRICAL PERFORMANCE SPECIFICATIONS

### 1-11 DYNAMIC SPECIFICATIONS

- a) VOLTAGE RECOVERY: Following a step in load current, the time required for the stabilized output voltage to recover to within the load effect band (or 2 mV whichever is greater): <50 microseconds.
- b) CURRENT RECOVERY: Following a step in load voltage, the time constant (RC) given by the load resistance (R) and the value for "C" as listed in Table 1-1).
- c) PROGRAMMING SPEED: PTR models slew at approximately 250 volts per second (depending on load conditions).

### 1-12 SPECIFICATIONS FOR OPTIONAL OVERVOLTAGE CROWBAR (PTR MODELS WITH SUFFIX "VP" ONLY)

- a) SETTING RANGE: 4.8 volts (minimum) to 110% of the rated maximum output voltage. Adjustment by means of built-in rheostat control ("VP LEVEL").
- b) THRESHOLD (difference voltage between value set by "VP LEVEL" control and output voltage): 5% of rated maximum output voltage or 0.5 volt, whichever is greater. Note: Setting should account for (-)4% warm-up setting effect.
- c) TEMPERATURE COEFFICIENT: 0.03% per °C.
- d) TRIGGERING TIME: <50  $\mu$ sec.

### 1-13 MECHANICAL SPECIFICATIONS AND MOUNTING

- a) See Mechanical Outline Drawing, FIG. 1-2.

### 1-14 ACCESSORIES

- a) One-unit rack adapter, Kepco Model RA 35-1.
- b) Three-unit rack adapter, Kepco Model RA 33-3.
- c) Four-unit rack adapter, Kepco Model RA 34-4.

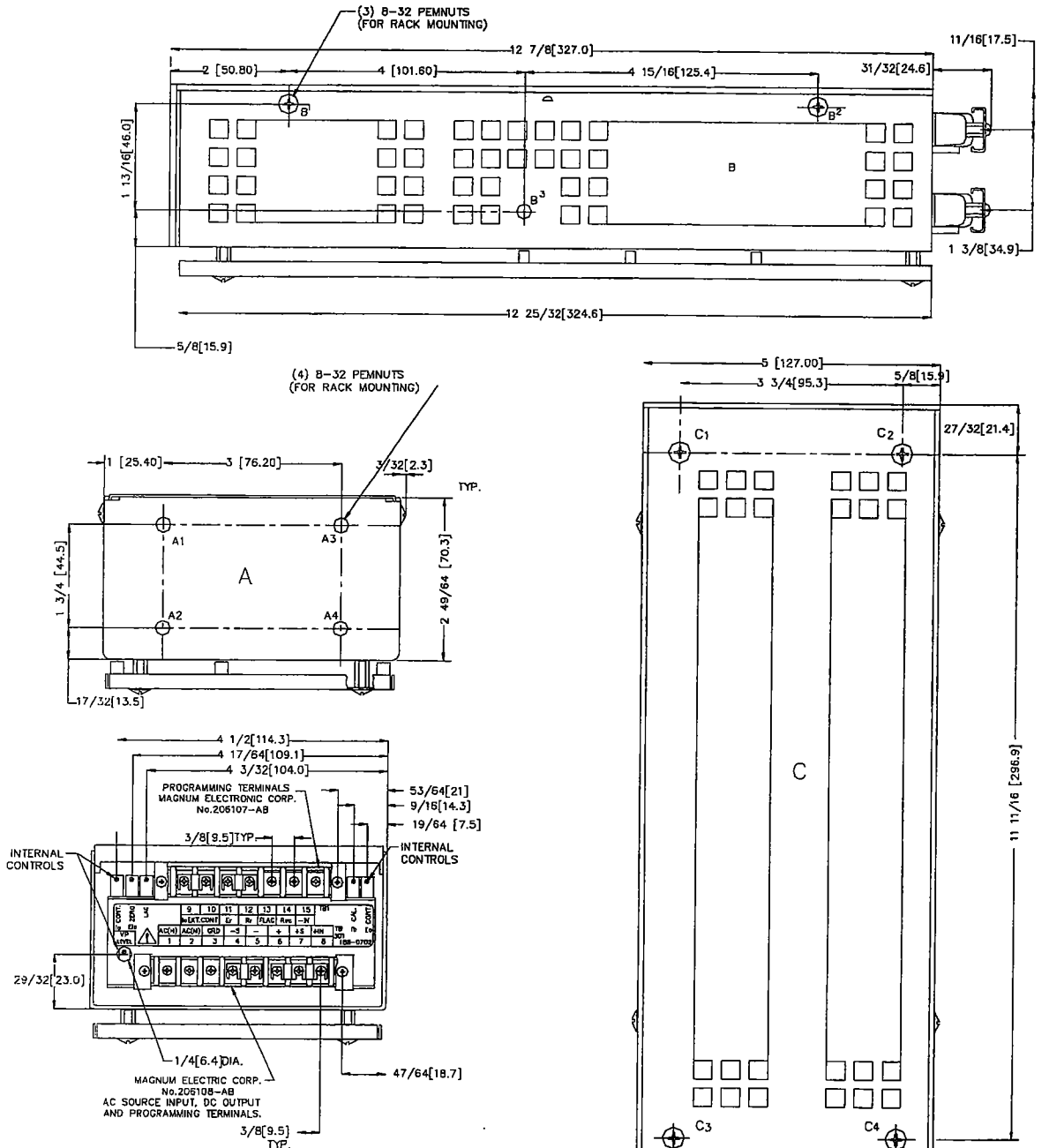

**NOTES:**

1. MATERIAL: CHASSIS-11 GAUGE (.090) ALUMINUM.  
TOP COVER } 16 GAUGE (.050) ALUMINUM  
BOTTOM COVER }
2. FINISH: BLACK ANODIZED.
3. UNIT CAN BE MOUNTED EITHER ON SURFACE "A",  
USING FOUR (4) 8/32x1/2 MACHINE SCREWS, OR ON SURFACE "C",  
USING FOUR (4) 8-32x1/2" MACH. SCREWS OR ON SURFACE "B",  
USING THREE (3) 8/32x1/2 MACHINE SCREWS. IF SURFACE "B" OR  
"C" IS USED.  
FOR MOUNTING, COVER HOLDING SCREWS "B<sup>1</sup>" AND "B<sup>2</sup>", OR C &  
THROUGH C MUST FIRST BE REMOVED. SCREWS LENGTHS GIVEN  
FOR 1/8" THICK MOUNTING SURFACES.
4. DIMENSIONS IN PARENTHESES ARE IN MILLIMETERS.
5. TOLERANCES: A) BETWEEN MOUNTING HOLES: ±1/64 INCH (±0.4 MILLIMETER).  
B) ALL FRONT PANEL DIMENSIONS: SEE MIL-STD-189.  
C) ALL OTHER DIMENSIONS: ±1/32 INCH (±0.8 MILLIMETER).

dm1663

**FIGURE 1-4. MECHANICAL OUTLINE DRAWING**



## SECTION II – INSTALLATION

### 2-1 UNPACKING AND INSPECTION

2-2 This power supply has been inspected and tested at the factory prior to packing and is shipped ready for operation. After careful unpacking, inspect the instrument for shipping damage before attempting to operate it. Perform an operational check as described below (see par. 2-10). If there is any indication of damage, file a claim immediately with the responsible transport service.

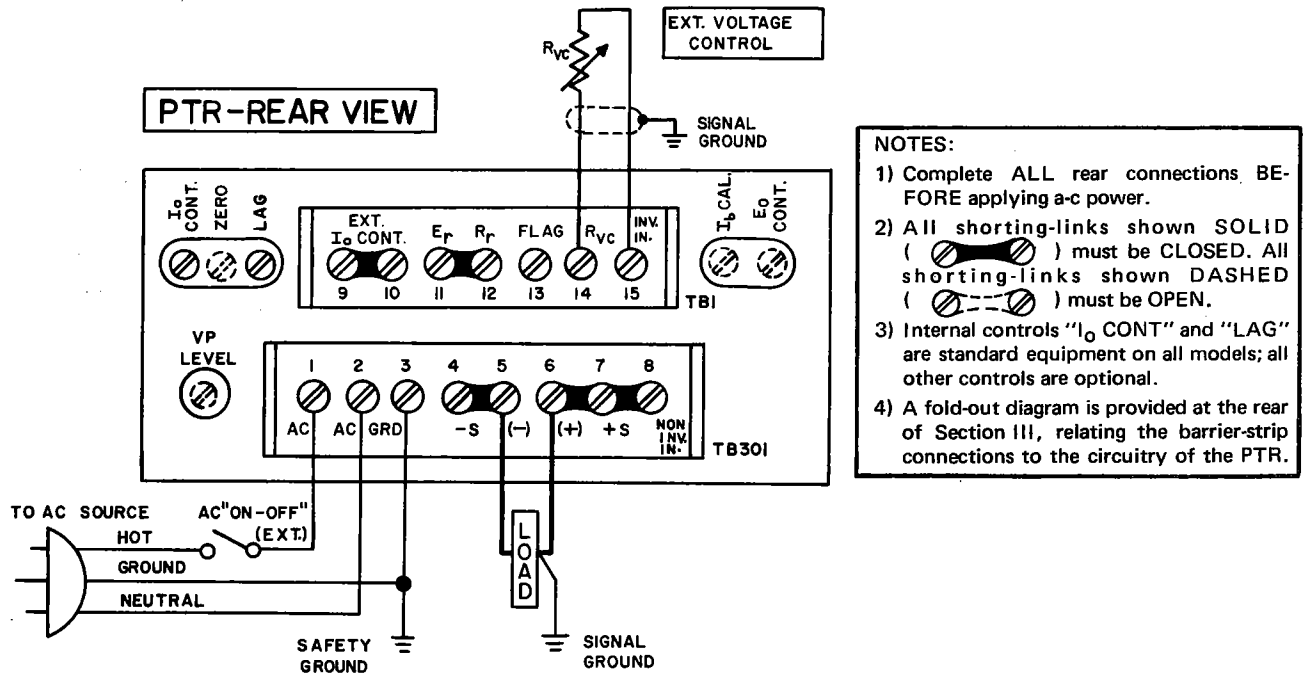

FIG. 2-1 REAR TERMINATIONS WITH JUMPER LINK CONNECTIONS FOR STANDARD POWER SUPPLY OPERATION, PTR GROUP.

### 2-3 TERMINATIONS

2-4 Two barrier-strips (TB1 and TB301) with a total of (15) screw-type terminals are provided. All a-c input, d-c output and programming connections are available here. A table of terminal functions (Table 2-1) and an illustration of the power supply rear (FIG. 2-1) is provided below:

TERMINAL NO.	FUNCTION
1,2,3	<b>A-C power and chassis ground terminals.</b> External a-c power switching should be performed either with a double pole switch or with a single pole switch in series with terminal No. 1 (a-c hot). Terminal (3) should always be returned to a reliable, low impedance a-c ground.
4,5,6,7	<b>Negative and positive d-c output and sensing terminals.</b> Output and sensing terminals are connected by removable links which must be removed for error sensing at the load.
8	<b>Noninverting, amplifier input.</b> Normally connected to the (+) sensing terminal. Link (7)–(8) is removed for noninverting programming.
9,10	<b>External current control.</b> Normally linked together. For external current control by either a remote potentiometer or a control voltage. (Internal Sensing Mode.)
11,12	<b>E<sub>r</sub>, R<sub>r</sub>.</b> Normally linked together. For disconnecting the internal reference source (E <sub>r</sub> ) from the internal reference resistor (R <sub>r</sub> ) when programming with external reference or control voltages.
13	<b>Flag Signal Output (with reference to terminal 7).</b> Indicates "I mode" or "V mode."
14,15	<b>Inverting input and R<sub>vc</sub>.</b> For connection of the external voltage control resistance. Terminal (15) is the inverting amplifier input (null junction) while terminal (14) is internally connected to terminal (4).

TABLE 2-1 REAR TERMINAL FUNCTIONS.

**NOTE:** All terminal functions, briefly listed in Table 2-1 are discussed in detail in the "Operation" section (Section III) of this manual.

2-5 **INTERNAL CONTROLS** All internal controls are accessible from the rear of the power supply and labeled consistent with the nomenclature used in the schematic diagram and in the text. Table 2-2 presents a listing of all controls and their functions, while FIG. 2-1 (and all illustrations in Section III) shows their physical location.

NAME OF CONTROL	REFERENCE DESIGNATION	FUNCTION
"I <sub>o</sub> CONT"	R9	STANDARD (ALL MODELS). Current control (internal sensing mode) also used for current limit adjustment in the voltage mode of operation.
"ZERO"	R12	OPTION (MODELS WITH SUFFIX "E" ONLY). Amplifier offset voltage control sets "zero" power supply output (with R <sub>VC</sub> = 0).
"LAG"	R15	STANDARD (ALL MODELS). Dynamic stability adjustment. Stabilizes power supply for a limited range of reactive load conditions.
"E <sub>o</sub> CONT"	R18	OPTION (MODELS WITH NUMERICAL SUFFIX ONLY). Built-in output voltage control rheostat.
"I <sub>b</sub> CAL"	R20	OPTION (MODELS WITH SUFFIX "R" ONLY). Control current calibration. Sets control current to exactly 1 mA in precision programming applications.

TABLE 2-2 INTERNAL CONTROLS AND THEIR FUNCTIONS.

## 2-6 A-C POWER REQUIREMENTS

2-7 This power supply is normally shipped for operation from a nominal 115V a-c source, 60 Hz single phase. The power supply can be quickly converted for 230V a-c source operation by changing the provided selector switch (S201) is located directly on the power transformer (T201) (refer to FIG. 2-2). For 230V a-c operation, the fuse for 115V a-c operation (F201) must be replaced by one with half the 115V rating. (See FIG. 2-2 for fuse values).

## 2-8 GROUNDING

- 2-9 a) **SAFETY GROUND.** For safety reasons, it is important that the metal chassis of the PTR Power Supply be connected to an a-c ground. If a 3-wire line cord and a properly grounded outlet are used, the grounding is automatically accomplished. If only a 2-wire line cord is used, the metal chassis of the power supply must be grounded separately by returning barrier-strip terminal (3) to an a-c ground.
- b) **SYSTEM GROUND.** The d-c output terminals of the PTR Power Supplies are isolated from the a-c power line and from the chassis, except for a capacitor/resistor series connection from the negative (-) output to chassis. Since no d-c connection exists to the chassis, either side of the power supply may be grounded. A maximum of 500V (d-c or p-p) can be connected between chassis and either output terminal. If the provided internal capacitor/resistor connection from (-) output to chassis is not desired, and the positive side of the PTR is to be grounded, the system ground may be established outside the power supply by removing the jumper (A)-(B) as shown in FIG. 2-2.

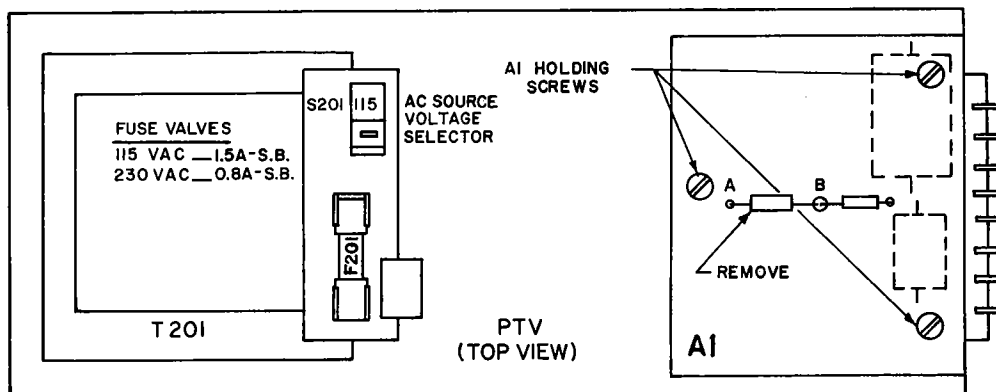

FIG. 2-2 CONVERSION TO 230V a-c OPERATION AND LOCATION OF INTERNAL SIGNAL GROUND.

## WARNING

REMOVE A-C POWER FROM POWER SUPPLY.

To remove the jumper, proceed as follows:

- 1) Remove the top cover holding screws as shown in Section "V" ("Disassembly").
- 2) Refer to FIG. 2-2. Remove (3) holding screws for assembly (A1) and lift assembly to the side.
- 3) Clip or unsolder wire jumper between terminals (A) and (B). Remount assembly (A1) and fasten. Remount PTR cover.

The output of the PTR Power Supply is now completely "floating." Either the positive *or* the negative output side may be grounded elsewhere in the system or at the load.

**NOTE:** Under these conditions the ripple specifications as given in Section I are no longer applicable. The ripple magnitude will be a function of circuit impedance to ground.

### 2-10 OPERATIONAL CHECK

2-11 After a-c power source selection has been made as described in par. 2-6, a functional check may be performed as follows:

Connect an external voltmeter (M1) to terminals (5)–(6) as shown in FIG. 2-3. Connect a line cord to terminals (1)–(2) with the ground wire to terminal (3).

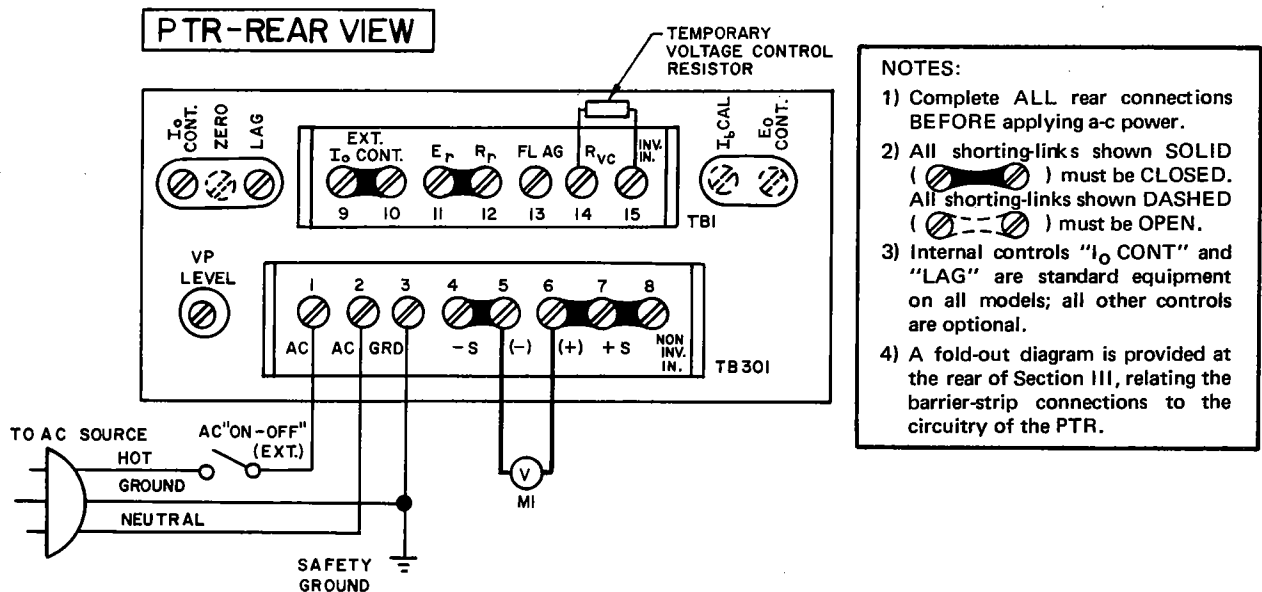

FIG. 2-3 OPERATIONAL CHECKOUT.

2-12 The resistor which is connected to terminals (14)–(15) serves as the voltage control resistor ( $R_{VC}$ ). It is intended for preliminary checkout purposes only. *Regulation and stability measurements require metal film or wirewound resistors with temperature coefficients of 20 ppm or better.* The output voltage measured on M1 should be proportional to the resistance of  $R_{VC}$ . Since a nominal 1000 ohms per volt control ratio is used in the PTR Power Supplies, the output voltage will be approximately equal to 1 mA times the kilohms across terminals (14)–(15). A variable resistor of appropriate value may be used to check the supply over its full output range.

2-13 MODELS WITH SUFFIX "VP" ONLY. The overvoltage crowbar circuit is factory adjusted to an output voltage level slightly higher than the maximum rated value of the model at hand. The "crowbar point" may be adjusted to any other output voltage level within the range of the output voltage (approximately 5% or 3 volts, w.i.g. to 110%). Adjust and check the "crowbar point" to any desired level as follows:

- Connect PTR supply and external components as shown in FIG. 2-4.
- Locate "VP LEVEL" control (R314) to the left of the lower barrier-strip in the rear (refer to FIG. 2-4). Turn completely clockwise.
- Adjust the desired output voltage *at which the overvoltage crowbar is to trigger* (NOT your operating voltage) by means of the "EXT. VOLTAGE CONTROL." Refer to FIG. 2-4. Make certain, this control is connected *exactly* as shown; i.e., *clockwise* rotation should cause an *increase* in output voltage.
- Slowly* turn the "VP LEVEL" control counterclockwise until the output voltage goes suddenly to "zero" as observed on the "OUTPUT VOLTMETER."
- Turn the "EXT. VOLTAGE CONTROL" counterclockwise (to *reduce* the output voltage). *Reset the crowbar circuit by momentarily removing and reapplying the a-c input power.*
- Recheck the crowbar point by *slowly* bringing the output voltage level to the previously adjusted "crowbar point" by means of the "EXT. VOLTAGE CONTROL." Readjust "crowbar point" if necessary by means of the "VP LEVEL" adjustment. Turn "EXT. VOLTAGE CONTROL" counterclockwise.
- Reset crowbar circuit and set your *operating output voltage* by means of the "EXT. VOLTAGE CONTROL." This operating voltage must be at least 5% or 0.5 volt, whichever is greater, *lower* than the set "crowbar point" on the "VP LEVEL" control, to avoid spurious triggering. This concludes the "VP" adjustment.

**NOTE:** The PTR Power Supply should be allowed to come to thermal equilibrium at its normal full load before final adjustment is made.

**CAUTION**

FOR PROPER OPERATION OF THE OVERVOLTAGE CROWBAR CIRCUIT A *MINIMUM* OUTPUT CURRENT SETTING OF ABOUT 20 mA (SCR HOLDING CURRENT REQUIREMENT) IS REQUIRED.

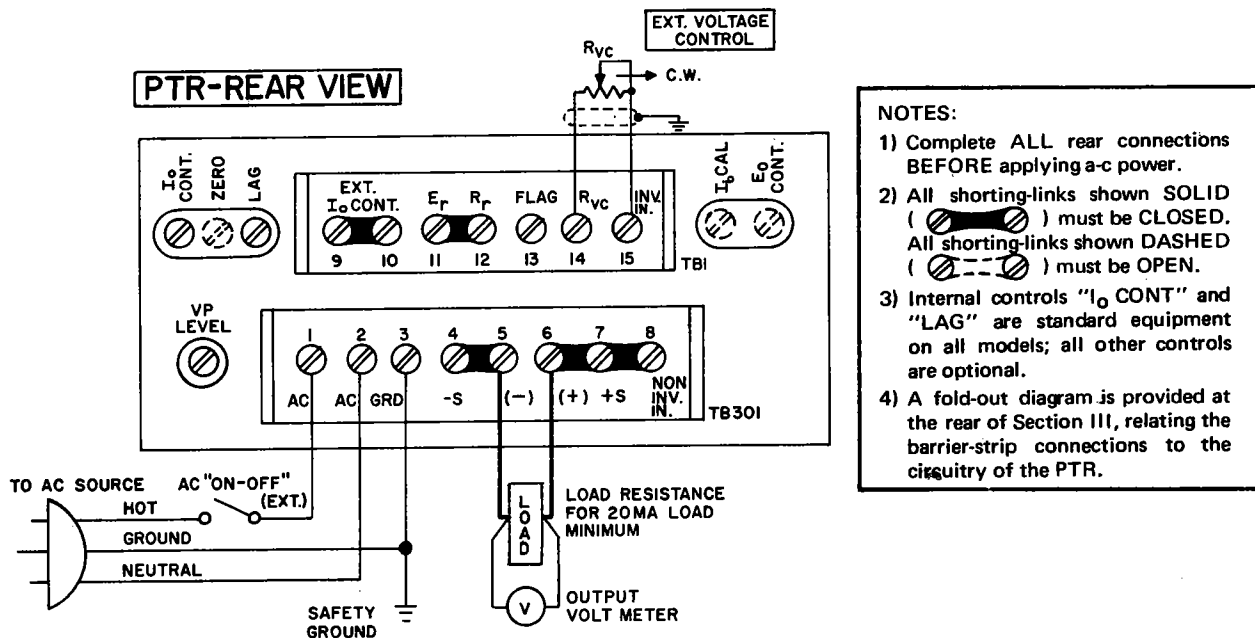

FIG. 2-4 OVERVOLTAGE CROWBAR SETUP CIRCUIT.



## SECTION III – OPERATION

### 3-1 GENERAL

3-2 The interconnections between the a-c power source, the stabilized power supply and the load are important to operator safety and to optimum power supply performance at the load. The following paragraphs should assist the user in the safe and efficient operation of the a-c power source/power supply/load system.

### 3-3 A-C (SAFETY) GROUNDING

#### WARNING

3-4 *National and international safety rules dictate the grounding of the metal cover and case of any instrument connected to the a-c power source.*

3-5 Kepco PTR Power Supplies have a 3-terminal, a-c power input at the rear barrier-strip to which a 3-wire connection (HOT, NEUTRAL, GROUND) to the a-c power line wiring must be made. These terminals are marked clearly and must not be interchanged during installation. If single pole a-c input switching is planned, the switch must be installed in series with the terminal marked "H" (hot or phase terminal).

### 3-6 D-C (SIGNAL GROUNDING)

3-7 Connections between the power supply and the load (load and sensing connections), as well as connections to the power supply amplifier (programming connections) will invariably, despite all precautions such as shielding, twisting of wire-pairs, etc., "pick-up" radiating noise and line frequency signals. To minimize this unwanted output, a d-c ground (SIGNAL GROUND) is needed.

3-8 Successful d-c (signal) grounding depends on careful analysis of the particular power supply/load application and only general guide lines can be provided here:

- 1) Avoid GROUND LOOPS at all costs. Ground loops are created by indiscriminate multiple grounding of the power supply load circuit. The load current flows through the existing impedance of the multiple ground points and gives rise to large noise voltages which are added to the power supply output.
- 2) GROUND LOOPS can be avoided only by the selection of a SINGLE GROUND POINT. Once the load circuit is connected, the output circuit (including the connected load) should be investigated (by means of an ohmmeter) for *complete isolation to ground*. *Only then* should a *single ground point* be selected.
- 3) The exact location of this *single ground point* can be established experimentally. For single, isolated loads, it may be located directly at *either* one of the power supply's output terminals by returning one of these terminals to the provided ground terminal (power supply case, common to a-c or safety ground). Often, the signal ground point may be located at the remote load. If the load has a "built-in" ground which cannot be disconnected, the single ground point must, of course, be established there.

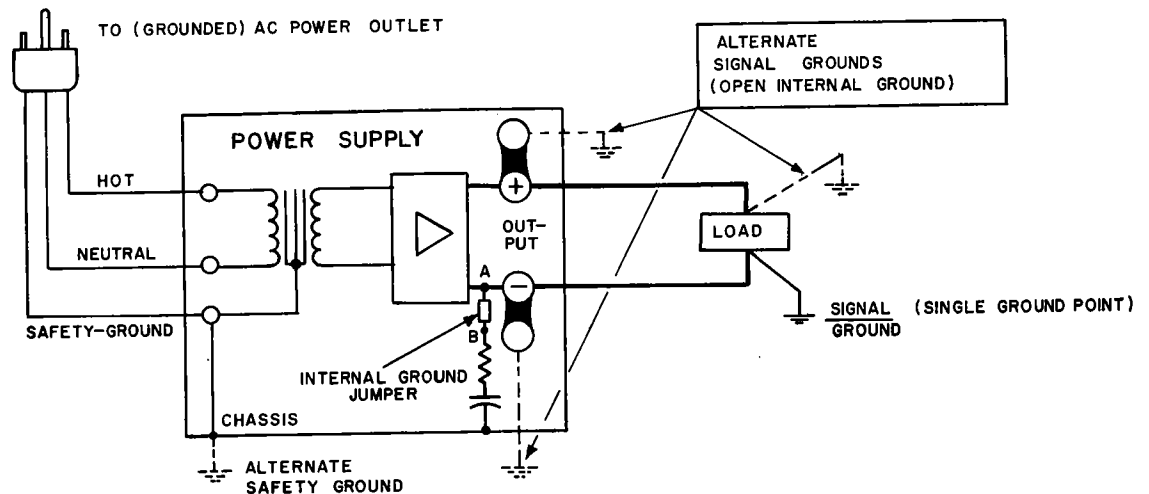

FIG. 3-1 ILLUSTRATION OF SAFETY AND SIGNAL GROUNDING.

- 3-9 In the PTR Power Supply, the negative side of the output is returned to the case via a resistor/capacitor combination (refer to the Main Schematic of the power supply), thus providing for an "internal" signal ground. If the signal ground must be established elsewhere (because of a grounded load, for example), the resistor/capacitor signal ground path must be opened in order to avoid ground loop problems. This step is also required if the positive output side of the power supply output must be used for d-c ground. The Installation Section (Section II) of this manual gives directions for the opening of the internal signal ground. If output polarity is not important, *either* the positive or the negative output of the power supply can be selected for the d-c ground point. Both sides should be tried and preference given to the ground point producing the least output noise. Output ripple specifications (as measured at the output) are however equally valid for either output side grounded.
- 3-10 In the case where the load must be kept completely "off ground" (d-c isolated) and the internal signal ground is not satisfactory, or the load must be operated "above ground," signal grounding can be accomplished by means of an external capacitor, connected from either side of the power supply output to the signal ground. The size of the capacitor should be carefully selected from the safety point of view (leakage current) and the desired noise-free output. A value between 0.1 and 1 microfarad has been found to be successful in many cases.
- 3-11 Additional signal grounding precautions are required while remote programming. Even simple remote control tasks, such as error sensing or resistance programming, a shielded, twisted wire pair with the shield (single ended) returned to the single d-c ground point. In cases where external programming sources are used, additional precautions are required. If all other grounding problems have been solved and a single ground point has been assigned to the system, the programming source must *be evaluated for system compatibility*. Some of the older signal generators, for example, cannot be successfully used for programming, since their cases are connected permanently to one of the output leads (and may, therefore, be improperly grounded). Many signal sources do not lend themselves to voltage programming, due to their tight coupling to the a-c line. In these cases, a completely isolated (battery driven) signal source is the only answer. Aside from these initial problems, however, the first step after a suitable signal source has been selected, the power supply/load system must have the correct polarity for voltage programming; e.g., the signal source "common" must be connected to the previously grounded output. If it is not, three choices are open: Either the programming source must be "floated;" i.e., it must operate above ground by an amount given by the output voltage of the power supply, or the selected d-c ground point must be changed to the polarity coinciding with that of the programming source, or a battery operated (nongrounded) source must be chosen.

### 3-12 POWER SUPPLY/LOAD INTERFACE

- 3-13 The basic function of a voltage or current stabilized power supply is to deliver the rated output quantities to the connected load. The load (or loads) may have any conceivable characteristic: It may be fixed or variable; it may have predominantly resistive, capacitive, or inductive parameters; it may be located very close to the power supply; or it may be a considerable distance away. Since the power supply designer cannot anticipate every conceivable application, location, or nature of the load, he must design his product for the widest possible application range and he must specify the performance at the *sensing terminals* of the power supply. The aim of the following paragraphs is to aid the user in the final use of the product: The interface of the power supply and the load.
- 3-14 The perfect interface between a power source and its load would mean that the specified performance at the output terminals would be transferred without impairment to any load, regardless of its characteristics, distance from the power supply or environment. To approach this ideal, not only must the power supply satisfy certain requirements, but interconnecting rules must be closely followed and Ohm's Law, as well as basic a-c theory, must be considered in selecting the interface wiring.
- 3-15 **LOAD WIRE SELECTION.** The feedback-stabilized d-c power supply is definitely not an ideal voltage source with zero output impedance at all frequencies. All power supplies of this type exhibit a rising output impedance with increasing frequency (refer to FIG. 3-2).

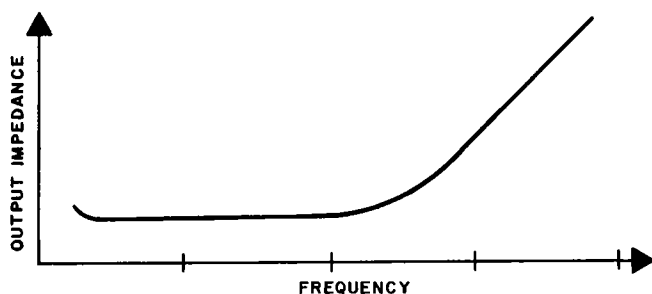

FIG. 3-2 TYPICAL OUTPUT IMPEDANCE VS. FREQUENCY FOR STABILIZED VOLTAGE SOURCES.

A realistic model for a voltage stabilized power supply must, therefore, include a series resistance representing the small d-c and low frequency source impedance in series with an inductance, representing the source impedance at higher frequencies. Load wire selection should, therefore, proceed with those facts in mind. The load-wire size should not only be selected for minimum voltage drop (Error Sensing, as discussed below, will take care of that) but also the series inductance of the load wire must be kept as small as possible compared to the source inductance of the power supply. (Error Sensing *cannot* compensate for this.) These dynamic considerations are especially important if:

- 1) The load is constantly changing in value.
- 2) The load is switched "on" and "off."
- 3) The supply is "step" programmed.
- 4) The load has a primarily reactive characteristic.
- 5) All other cases where the dynamic output response of the power supply is considered important.

As a general rule, the maximum practicable wire gauge should be selected for both, error sensing and load wires. NOTE: Maximum wire gauge capacity for PTR terminals is AWG 14.

### 3-16 LOAD CONNECTION, GENERAL

3-17 Kepco has provided sensing and output terminals at the barrier-strip (TB301) of the PTR Power Supply which permit maximum flexibility in power supply/load interface techniques. Although all applications tend to exhibit their own problems, the basic interconnections described may be used as a general guide in the interconnection between power supply and load.

3-18 The Kepco PTR Power Supply is shipped from the factory with (5) jumper links connected to the barrier-strips. These links may be removed and replaced at will, depending on the operating mode and application of the power supply. Links remaining on the barrier-strip must be tightly secure. LOOSE WIRES OR LINKS AT THE BARRIER-STRIP WILL CAUSE MALFUNCTION OF THE POWER SUPPLY.

### 3-19 LOAD CONNECTION, METHOD I (LOCAL, NONCRITICAL LOADS)

3-20 (Refer to FIG. 3-3.) The simplest power supply interconnection to primarily resistive, relatively constant loads, located close to the power supply, consists of a 2-wire connection from the output terminals [terminals (5) and (6)]. Load wire is selected as described previously (refer to par. 3-15). The load leads should be tightly twisted to reduce "pick-up" from stray magnetic fields. After the grounding rules have been applied (refer to par. 3-3 to 3-11), and the voltage control resistor has been selected (refer to par. 3-27), the power supply can be connected to the a-c source and operation may commence. This load connection is recommended only for applications where the voltage drop in the resistance of the load wires is of minor consequence, as for example for noncritical loads, operating in the Voltage Mode, or for Current Mode operation.

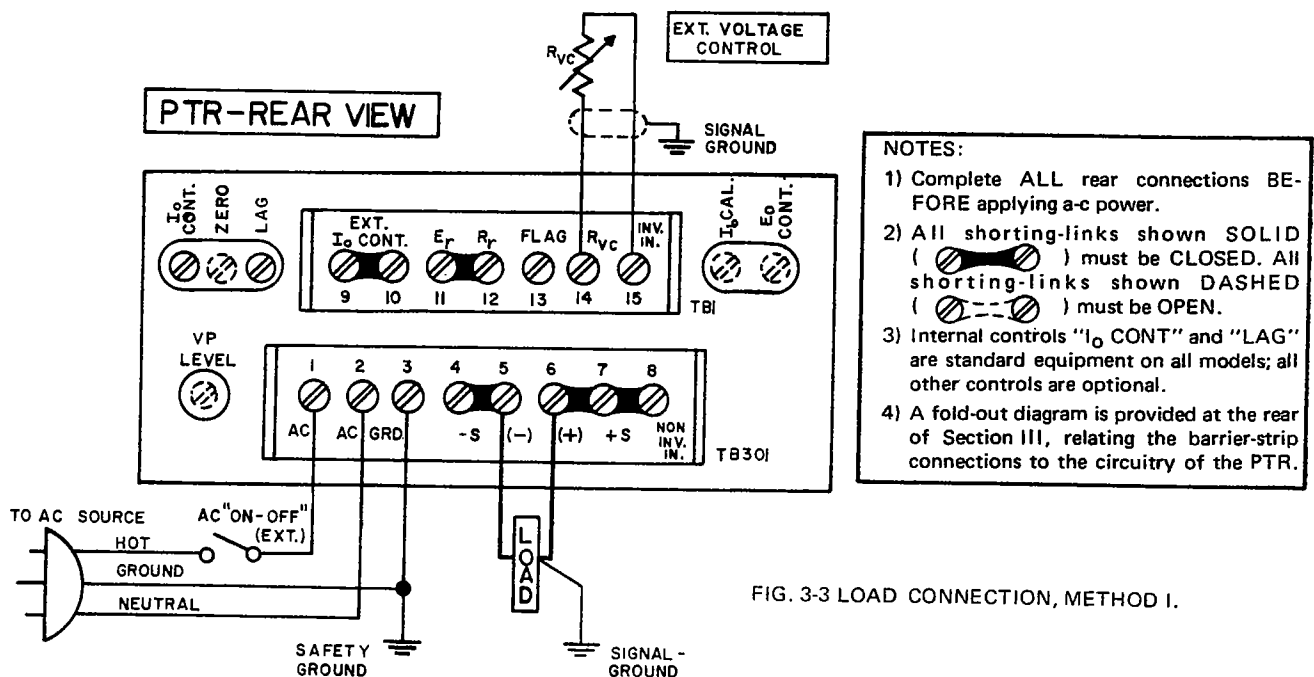

FIG. 3-3 LOAD CONNECTION, METHOD I.

### 3-21 LOAD CONNECTION, METHOD II (REMOTE ERROR SENSING)

3-22 Specified voltage stabilization performance *directly at the load* requires the use of remote error sensing. A twisted, shielded pair of wires from the sensing terminals to the load will compensate for load wire voltage drops up to 0.5 volt per wire (refer to FIG. 3-4). Observe polarities: The *negative sensing wire* (from terminal 4) must go to the *negative load wire*, and the *positive sensing wire* (from terminal 7) goes to the *positive load wire*.

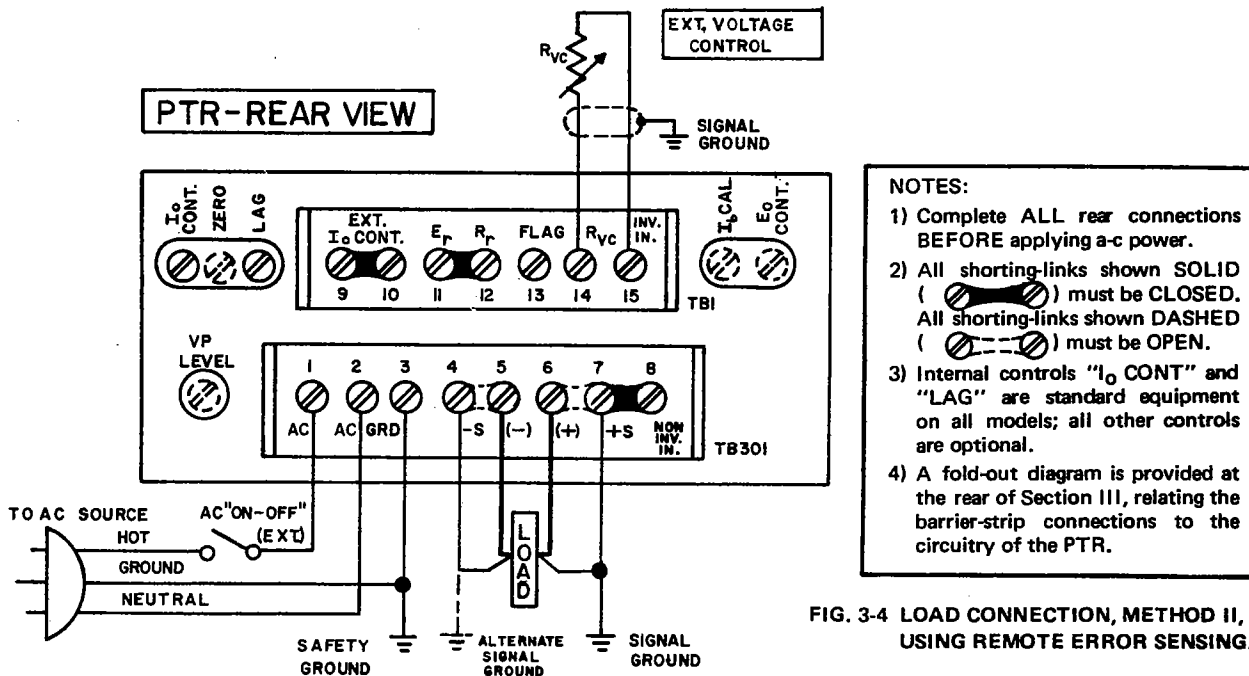



FIG. 3-4 LOAD CONNECTION, METHOD II, USING REMOTE ERROR SENSING.

- NOTES:
- 1) Complete ALL rear connections BEFORE applying a-c power.
  - 2) All shorting-links shown SOLID (  ) must be CLOSED. All shorting-links shown DASHED (  ) must be OPEN.
  - 3) Internal controls "I<sub>o</sub> CONT" and "LAG" are standard equipment on all models; all other controls are optional.
  - 4) A fold-out diagram is provided at the rear of Section III, relating the barrier-strip connections to the circuitry of the PTR.

**CAUTION!** IN ALL VOLTAGE MODE APPLICATIONS, THE "I<sub>o</sub> CONT" CONTROL FUNCTIONS AS A "CURRENT LIMIT" ADJUSTMENT. THE "I<sub>o</sub> CONT" CONTROL IS FACTORY-SET FOR THE *MAXIMUM RATED OUTPUT CURRENT*. RESET FOR *YOUR* LOAD REQUIREMENTS AS DESCRIBED IN SECTION V, PAR. 5-6. DO NOT ADJUST "I<sub>o</sub> CONT" CONTROL TO HIGHER THAN FACTORY-SET VALUE.

3-23 This method of load interconnection (Method II) can be used for loads *not* requiring rapid changes of the power supply output and for programming with gradually changing input signals (sine or triangular signals).

### 3-24 LOAD CONNECTION, METHOD III (EXTERNAL LOAD CAPACITOR)

3-25 This method is recommended if step changes in the load are expected (if, for example, the load is partially or completely disconnected or shorted) or if the power supply is programmed with step functions (square wave, pulse operation, etc.). To obtain low dynamic impedance at the remote load, an external capacitor should be connected *directly across the load terminals* (refer to FIG. 3-5). The value of the external capacitor should be at least as large or larger than the internal output capacitor of the PTR Power Supply (C305, see Main Schematic or Parts List). This external capacitor is a supplement to the internal output capacitor (C305), bypassing the wire inductance between the power supply and the load.

3-26 If instability (oscillation) is observed at the output or at the load, the power supply's amplifier should be restabilized by adjusting the provided lag network ("Lag," R15, see FIG. 3-5 et.al.) until stable operation is resumed.

**NOTE:** There is, unfortunately, no "best" method for interconnecting the load and the power supply. Individual applications, location and nature of the load require careful analysis in each case. Signal grounding a single point in the output circuit is of great importance.

It is hoped that the preceding paragraphs will prove helpful in most cases. For help in special applications or difficult problems, consult directly with Kepco's Application Engineering Department.

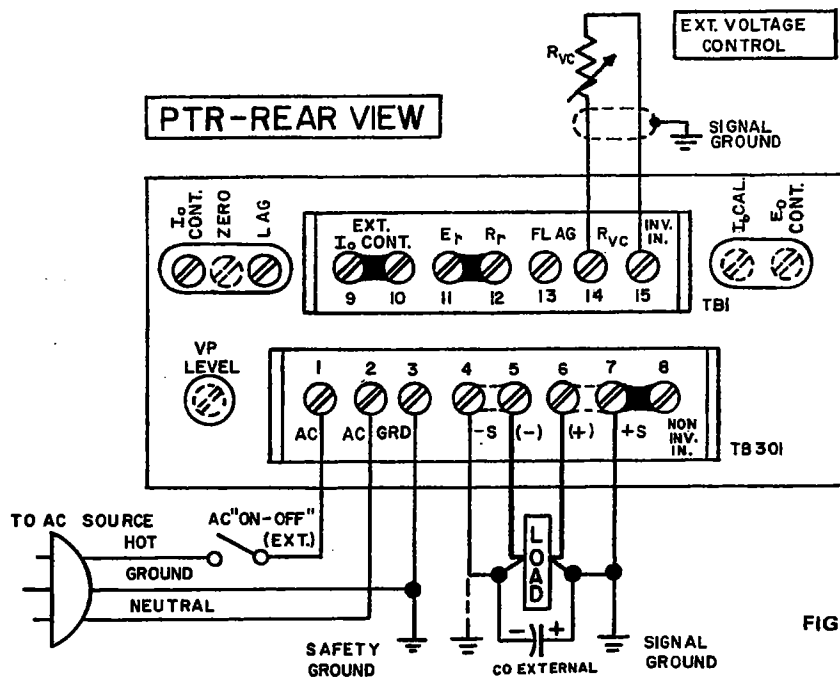



- NOTES:**
- 1) Complete ALL rear connections BEFORE applying a-c power.
  - 2) All shorting-links shown SOLID (  ) must be CLOSED. All shorting-links shown DASHED (  ) must be OPEN.
  - 3) Internal controls "I<sub>o</sub> CONT" and "LAG" are standard equipment on all models; all other controls are optional.
  - 4) A fold-out diagram is provided at the rear of Section III, relating the barrier-strip connections to the circuitry of the PTR.

FIG. 3-5 LOAD CONNECTION, METHOD III, USING EXTERNAL CAPACITOR.

**CAUTION!** IN ALL VOLTAGE MODE APPLICATIONS, THE "I<sub>o</sub> CONT" CONTROL FUNCTIONS AS A "CURRENT LIMIT" ADJUSTMENT. THE "I<sub>o</sub> CONT" CONTROL IS FACTORY-SET FOR THE MAXIMUM RATED OUTPUT CURRENT. RESET FOR YOUR LOAD REQUIREMENTS AS DESCRIBED IN SECTION V, PAR. 5-6. DO NOT ADJUST "I<sub>o</sub> CONT" CONTROL TO HIGHER THAN FACTORY-SET VALUE.

### 3-27 STANDARD POWER SUPPLY OPERATION (STABILIZED OUTPUT VOLTAGE)

3-28 GENERAL. The PTR Power Supply is shipped from the factory with (5) removable jumper links and a small resistor in place at the rear barrier-strips (refer to FIG. 2-3). The resistor is a temporary voltage control resistance which provides (approximately) rated output voltage. This resistor is provided for preliminary check-out purposes and should be replaced by a high quality component having a temperature coefficient of 20 parts per million or better (approximately 1000 ohms for each volt of output required, see par. 3-29), before stability measurements or actual operation of the power supply. *All terminal screws on the barrier-strips must be secured tightly*, since loose connections may cause malfunction of the power supply.

3-29 FIXED OUTPUT VOLTAGE. After the proper interconnections between a-c power source, the power supply and the load have been made (refer to par. 3-1 to 3-26 for the selection of grounding and load connection methods) a-c input power can be applied and operation can commence. The PTR Power Supply will deliver fixed output voltage, proportional to the resistance across terminals (14) and (15):  $E_o \approx R_{vc} \times 1 \text{ mA}$ , where  $E_o$  designates the output voltage and  $R_{vc}$  the resistance across the barrier-strip terminals.\*

3-30 VARIABLE OUTPUT VOLTAGE. The output voltage of the PTR Power Supply may be varied from approximately zero to its maximum rated value by replacing the supplied fixed voltage control resistor by a suitable rheostat. The control ratio (ohms per volt) is approximately\* 1000 ohms per volt in all PTR Power Supplies, so that for each 1 kilohm of control resistance, 1 volt of output voltage will be available. A good quality, wirewound or metal film potentiometer (rheostat connected) should be used as the voltage control resistance. Shielding of the leads going to the voltage control is recommended to reduce ripple "pickup." Return the shield (single ended) to the chosen "signal ground."

\*For exact calibration of the programming ratio, see par. 3-70.

### 3-31 THE PTR POWER SUPPLY AS A CURRENT STABILIZER

3-32 PTR Power Supplies can be conveniently operated as a stabilized CURRENT SOURCE. Two basic methods may be used: For less critical applications, stabilized current output (stabilization:  $\Delta I_o < 5 \text{ mA}$ ) can be achieved by operating in the "Current Mode." For more demanding applications, stabilized current output (stabilization  $\approx \pm 0.01\%$  of rated output current) can be produced by the use of external sensing and control components. Both methods are described in this section.

3-33 For users not thoroughly familiar with current stabilized sources, a few general remarks about these devices may be in order. The properties which typify a current stabilizer can perhaps best be shown by an analogy with an equivalent voltage stabilizer. For any given range of load resistances, the latter keeps its output voltage constant while its load current changes. The current stabilizer, on the other hand, keeps its output current constant while its output voltage "complies" with the demands of the load resistance and changes accordingly. (For this reason the output voltage of a current stabilizer is termed the "Compliance Voltage.")

3-34 Each power source has a load range which is determined by the setting of its output controls. If these controls are set to the maximum output voltage ( $E_O \text{ MAX}$ ) and to the maximum output current ( $I_O \text{ MAX}$ ), then:

a) In the case of a voltage stabilizer, the *minimum* load resistance is given by:

$$E_O \text{ max}/I_O \text{ max} = R_L \text{ min}$$

Load resistances *lower* than  $R_L \text{ min}$ . will result in transfer to the "current limit" mode, while higher load resistance (as for example  $R_L^1$ ,  $R_L^2$  in FIG. 3-6A) will result in reduced output current until at  $R_L = \infty$ ,  $I_O = 0$ .

b) In the case of a current stabilizer, the *maximum* load resistance is given by:

$$E_O \text{ max}/I_O \text{ max} = R_L \text{ max}$$

Load resistances higher than  $R_L \text{ max}$  will result in transfer to the "voltage limit" mode, while lower load resistances (as for example  $R_L^1$ ,  $R_L^2$  in FIG. 3-6B) will result in reduced output or compliance voltage ( $E_O$ ) until at  $R_L = 0$ ,  $E_O = 0$ .

3-35 We see then that while voltage and current sources are both limited in their load range, their limitations go in exactly opposite directions, the "Crossover Resistance" for both voltage and current stabilizers being given by  $E_O \text{ max}/I_O \text{ max}$ . A comparison of both sources and an illustration of the previous paragraphs are shown in FIG. 3-6. While the load range for the voltage stabilizer is from infinity ohms to  $R_L \text{ min} = E_O \text{ max}/I_O \text{ max}$ , that for the current stabilizer is from  $R_L \text{ max} = E_O \text{ max}/I_O \text{ max}$  to zero ohms.

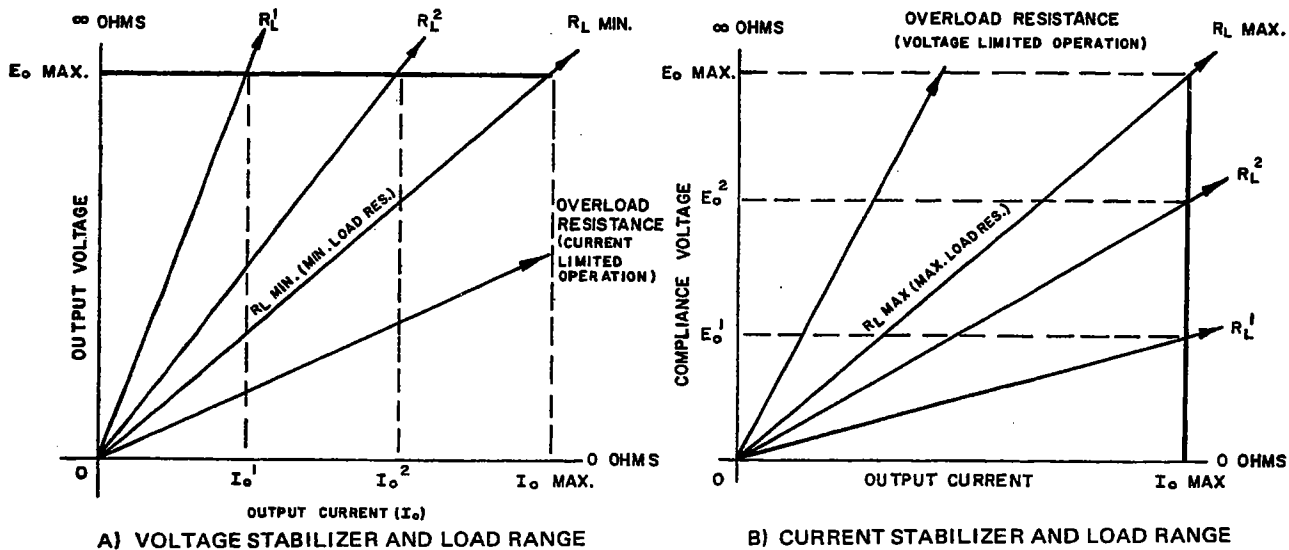

FIG. 3-6 OPERATING CHARACTERISTIC, VOLTAGE VS. CURRENT STABILIZER.

### 3-36 STANDARD POWER SUPPLY OPERATION (STABILIZED OUTPUT CURRENT)

3-37 For loads requiring relatively *high* stabilized output currents which can tolerate moderate current variations (approximately 5 mA max.), the PTR Power Supply can be operated as a current stabilized source in the *internal current mode*. For loads requiring relatively *low* output current, external current control and sensing must be used (refer to par. 3-40). In the *external current mode* "voltage limiting" is fixed (approximately 150% of the maximum output voltage) and is *not* adjustable.

**NOTE:** If, for example, an output current of 5 amperes is required, a variation of 5 mA represents an output change of 0.1% and the internal current stabilizing mode might be applicable. If, however, only 0.1 ampere load current is required, the 5 mA variation represents an output change of 5%, and the external stabilizing mode should be considered.

3-38 For operation in the *internal current mode*, the PTR Power Supply can be connected exactly as for "Voltage Mode" operation (refer to FIG. 3-5). The setting of the voltage control resistor ( $R_{VC}$ ) will determine the maximum load range and the "crossover" point between stabilized voltage/stabilized current operating modes. (Example: A Model PTR 21-2.5, with its external  $R_{VC}$  set to deliver 20 volts, and the " $I_O \text{ CONT.}$ " current control set to 2.5 amperes, has a maximum load range from zero ohms to  $20V/2.5A = 8$  ohms, For loads in this resistance range, it will deliver stabilized current, adjustable from approximately zero to 2.5 amperes. For loads higher than 8 ohms, the power supply will transfer into the voltage stabilizing mode.) The output

current is adjusted by means of the internal output current control ( $I_O$  CONT-R9. Note: Link (9)-(10) on TB1 must be *closed*). The output current can also be controlled remotely, as illustrated in FIG. 3-7, by means of an externally located potentiometer (EXTERNAL CURRENT CONTROL, 1 K ohms, Note: Link (9)-(10) on TB1 must be *open*, in series with a 12 K ohm fixed resistor).

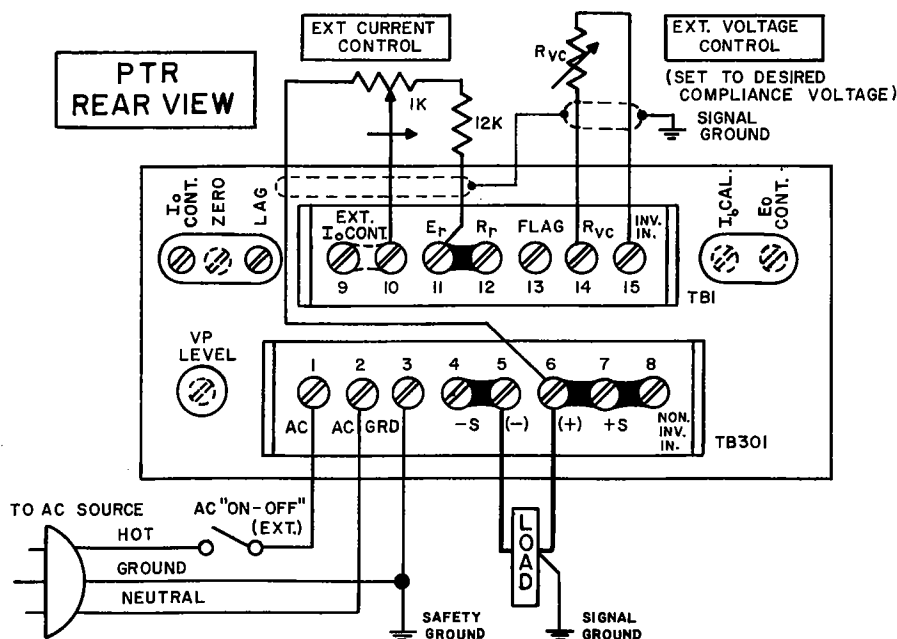
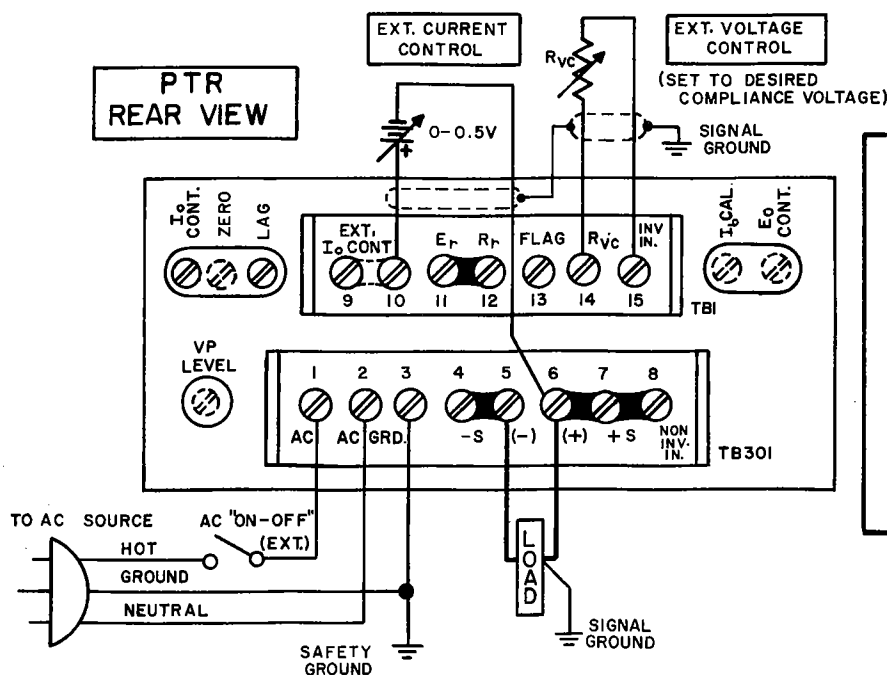

FIG. 3-7 CONNECTIONS FOR INTERNAL CURRENT MODE OPERATION, EXTERNAL RESISTANCE CONTROL.

3-39 Alternately, the output current can be controlled externally by a variable, unipolar control voltage. With the PTR connected as shown in FIG. 3-8, the output current will vary from zero to maximum rated output as the control voltage is adjusted from zero to  $\approx (+) 0.5$  volt. The output current can alternately be controlled by an external voltage source (for example, from a digital processor via the Kepco Model SN-2 D/A Converter).



NOTES:



- 1) Complete ALL rear connections BEFORE applying a-c power.
- 2) All shorting-links shown SOLID (  ) must be CLOSED. All shorting-links shown DASHED (  ) must be OPEN.
- 3) Internal controls "I<sub>O</sub> LIM" and "LAG" are standard equipment on all models; all other controls are optional.
- 4) A fold-out diagram is provided at the rear of Section III, relating the barrier-strip connections to the circuitry of the PTR.

FIG. 3-8 CONNECTION FOR INTERNAL CURRENT MODE OPERATION, EXTERNAL VOLTAGE CONTROL.

**NOTE:** Any *parallel* resistance added to the output in the constant current mode of operation (voltmeter, etc.) will *increase* the specified stabilization error ( $\Delta I_O < 5$  mA). Output voltage (compliance) can be monitored *only* by using very high impedance metering (voltmeters with FET input stage or VTVM's).

### 3-40 THE CONTROL OF SMALL OUTPUT CURRENTS WITH THE PTR

3-41 GENERAL. The specified errors for operation in the "internal current control mode" ( $\Delta I_o < 5 \text{ mA}$ ) generally preclude the use of this mode of operation for output currents near to or below 5 mA. (At an output current of  $I_o = 50 \text{ mA}$ , the "worst case" error percentage would be 10%!) For applications where these errors are not tolerable, an external current control circuit must be chosen. Three basic circuits are described in the following paragraphs, all of which use the PTR *Voltage Amplifier* and an external feedback circuit to stabilize the output current. The selection of a particular circuit will depend on the output current requirements, desired control mode and the grounding situation. The three circuits are listed below:

- EXTERNAL SENSING AND RESISTANCE CONTROL. Suitable for output current control from  $10 \mu\text{A}$  to maximum rated value. *Positive* output grounded (par. 3-42).
- EXTERNAL SENSING AND VOLTAGE CONTROL. Suitable for output current control from  $1 \mu\text{A}$  to 1 mA. *Positive* output grounded (par. 3-50).
- EXTERNAL VOLTAGE CONTROL (WITHOUT SENSING RESISTOR). Output current control from 1 to  $100 \mu\text{A}$ . *Negative* output grounded. Suitable for application where positive grounding cannot be used (par. 3-58).

**CAUTION**

- The previously outlined restrictions on the *load range* and on the *compliance voltage range* for each PTR model operating in the *internal* current control mode are equally applicable for operation in the *external* current control mode (refer to par. 3-31).
- In the *external* current control mode, voltage limiting is fixed to approximately 150% of rated output voltage and is *not* adjustable. PTR models with suffix "VP" have a built-in variable overvoltage crowbar circuit, which shorts the output should the load circuit be opened or the maximum load resistance be exceeded.
- In the *external* current control mode, the internal  $I_o$  CONTROL (R9) serves as a "back-up" current limit; i.e., its setting determines the maximum output current which may be programmed by the external current control.

### 3-42 EXTERNAL CURRENT SENSING AND RESISTANCE CONTROL

3-43 COMPONENT SELECTION. The external resistors for the current control circuit must be high-quality units with temperature coefficients not exceeding 20 parts per million. Their values are calculated using the simplified equation for the output current of the power supply in this mode of operation:

$$I_o = I_b \left( \frac{R_{CC}}{R_s} \right) + I_b, \text{ (Eq. 1)}$$

where:  $I_b$  = Control Current  
 $I_o$  = Output current  
 $R_{CC}$  = Current Control Resistance  
 $R_s$  = Current Sensing Resistance

**NOTE:** This equation (Eq. 1) is derived from the equivalent diagram shown below (refer to FIG. 3-9) and is valid for the "zeroed" PTR.

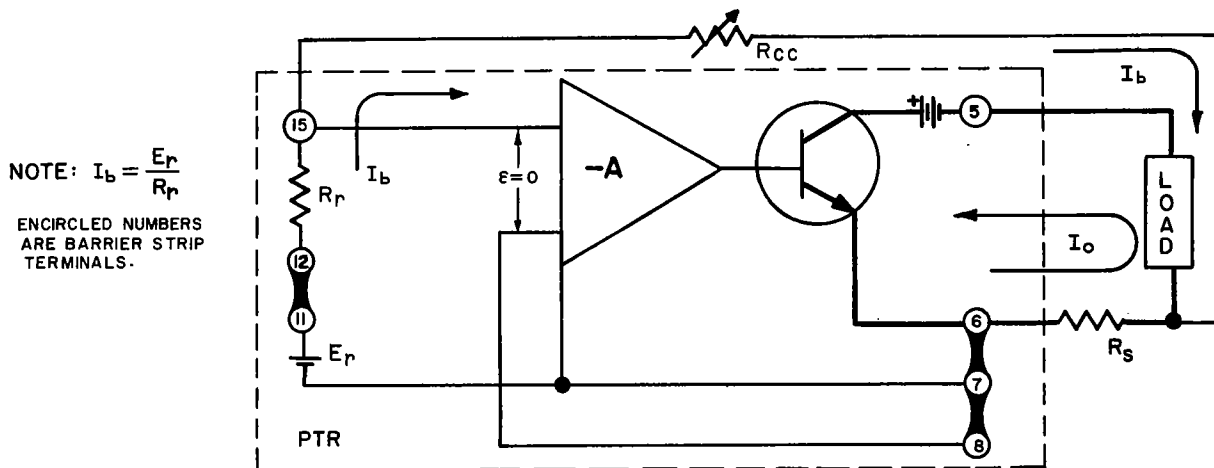

FIG. 3-9 EQUIVALENT DIAGRAM, PTR WITH EXTERNAL SENSING AND RESISTANCE CONTROL.



3-44 The circuit shown in FIG. 3-9 is suitable for output currents from the rated maximum of the PTR down to about 10  $\mu$ A. The components for the circuitry are selected as described below:

- a) CURRENT SENSING RESISTOR ( $R_S$ ). The value of the current sensing resistor ( $R_S$ ) is chosen to develop a voltage drop ( $V_S$ ) of 1 volt at the maximum desired output current ( $I_O$  max):

$$R_S = 1V/I_O \text{ max.}$$

The value of 1 volt for the sensing voltage ( $V_S$ ) is somewhat arbitrary and the value of  $R_S$  may be therefore the closest standard resistance available. A wide departure from the recommended value should, however, be avoided because of the following considerations. While a large value of  $V_S$  (and therefore  $R_S$ ) is desirable for a good signal/noise ratio, the sensing voltage sample is lost at the output and must be subtracted from the available rated compliance voltage. Also a large sample voltage is not desirable in view of the power dissipation caused in the sensing resistor ( $R_S$ ). Since all the load current is flowing through  $R_S$  and a high gain amplifier circuit is connected across it, all *extraneous* changes (such as those caused by self-heating) must be kept as low as possible.

In view of these considerations, it has been found that the recommended value for  $V_S$  (1 volt) provides an acceptable signal/noise ratio for current control over a range of 1:10. *If several decades of current must be controlled, a new sensing resistor must be selected for each range.* All sensing resistors should be calculated to drop 1 volt at the maximum output current for each range.

- b) CONTROL CURRENT ( $I_b$ ). The internal zener voltage source of the PTR ( $E_T$  6.2V nominal) can deliver a maximum control current of 1.2 mA with its internal reference resistor ( $R_T$ ) connected as shown in FIG. 3-9. PTR models with suffix "R" are equipped with a calibrating control ( $R_{18}$ —1 K ohm) in series with  $R_T$ , which permits calibration of  $I_b$  to 1 mA. This " $I_b$  CAL" or calibration control can be added internally by the user (refer to Section V of this manual) or, a rheostat may be added externally, between terminals (11) and (12) on TB1. The standard (1 mA) control current ( $I_b$ ) may be reduced to smaller values as required, by connecting an external resistance between terminals (11) and (15). The required values are given in Table 3-1.

$I_O$ RANGE	$I_b$	$R_T$	$R_{CC}$	$R_S$
10 mA – 100 mA	1 mA	6.2 K ohm	1000 ohm	10 ohm
1 mA – 10 mA	100 $\mu$ A	62 K ohm	10 K ohm	100 ohm
100 $\mu$ A – 1 mA	10 $\mu$ A	620 K ohm	100 K ohm	1000 ohm

TABLE 3-1 VALUES FOR EXTERNAL SENSING AND CONTROL CIRCUITS.

**NOTE:** The values in this table are calculated using the output equation (Eq. 1). They are valid for a sensing voltage 1 volt at  $I_O$  max. and for the PTR with a "zero" control (option "E").

- c) CURRENT CONTROL RESISTANCE ( $R_{CC}$ ). The current control resistance may be a fixed resistor, a step-controlled decade box or a rheostat. The resistors should be high quality components with a minimum temperature coefficient of 20 parts per million. The value of  $R_{CC}$  is determined by substituting selected values (for  $I_O$ ,  $I_b$  and  $R_S$ ) into the equation (Eq. 1, given in par. 3-42) and solving for  $R_{CC}$ . (Refer to Table 3-1 for tabulated values.)

3-45 CALIBRATING THE OUTPUT. As seen from the output equation (Eq. 1) the minimum output current ( $I_O$ ) with the control resistance at zero ohms ( $R_{CC} = 0$ ) is equal to the value of the control current ( $I_b$ ). A compensating circuit is provided in the PTR Power Supply (Models with suffix "E") which is used to "zero" the control current effect and allow the output current to reach "zero." The maximum value of the output current is calibrated by adjusting the control current. A trim rheostat is provided for this purpose (Models with suffix "R"). Both controls ("E" and "R" options) may be added by the user (refer to Section V of this manual) or, alternately, both controls may be added externally:

- a) A "zero" control can be added externally by connecting an adjustable voltage divider network between the built-in reference source ( $E_T$ ) and the noninverting amplifier input as shown in FIG. 3-10.
- b) An external trim rheostat for calibrating the control current (and thereby the maximum output current) may be added by inserting a rheostat between terminals (11)–(12) on TB1. The value of the trim-rheostat or resistor depends on the value of  $R_T$  (see Table 3-1). It should be approximately 10% of the  $R_T$  value.

3-46 OUTPUT MEASUREMENTS. Output current measurements may be performed either with an ammeter in series with the load, or for better accuracy, across a measuring resistor ( $R_M$ ) in series with the load, paralleled by a digital voltmeter. The series "Measuring Resistor" ( $R_M$ ) should be of a similar value as the sensing resistor. Voltage measurements across  $R_M$  must be divided by the resistance value of  $R_M$  to convert the results into ampere units. Stabilization measurements may be performed with a sensitive "Null" type millivolt meter in series with a stable, adjustable voltage source (see FIG. 3-10). After the output current ( $I_O$ ) is adjusted, the voltage drop across the measuring resistor ( $R_M$ ) is "nulled" by means of the adjustable voltage source. If the load resistance is now shorted, the deviation of the "Null" meter ( $\Delta V$ ), divided by the value of the sensing resistor, is an indication of the d-c stability of the output current. In percent:

$$\Delta I_O (\%) = \frac{\Delta V / R_M}{I_O} \times 100\%.$$

3-47 RIPPLE. Excessive output current ripple, as observed with an oscilloscope across the measuring resistor ( $R_M$ ), can often be greatly reduced by an electrolytic capacitor across the sensing resistor ( $R_S$ ). Since the major ripple component is the source frequency, the capacitor must have a low impedance compared to  $R_S$  at this frequency. The voltage rating must be at least as high as the drop across  $R_S$ .

3-48 EXAMPLE I. To summarize the material presented in the previous paragraphs (3-42 to 3-47), a circuit for external sensing and resistance control is shown in FIG. 3-10 below. A PTR model is used to deliver stabilized output current from 0–10 mA into a fixed load. From the table of values (Table 3-1) we have:

- $I_b = 100 \mu A$
- $R_s = 100 \text{ ohm}$
- $R_{cc} = 10 \text{ K ohm}$
- $R_r = 62 \text{ K (nominal value, trim with series rheostat for exact } I_b)$ .

3-49 Connect all components as shown in FIG. 3-10. The sensing resistor ( $R_S$ ) should be located as close to the power supply as possible. The leads connecting the control resistance ( $R_{CC}$ ) must be shielded, with the shield (single-ended) connected to the signal ground. The signal ground point must be selected carefully to avoid ground-loops. Note: PTR supplies have an internal "signal ground," consisting of a resistor/capacitor series connection from the negative output to chassis. This ground connection must be removed if the signal ground is established externally as shown. Refer to Section II (par. 2-8) of this manual for the location of the internal ground connection.

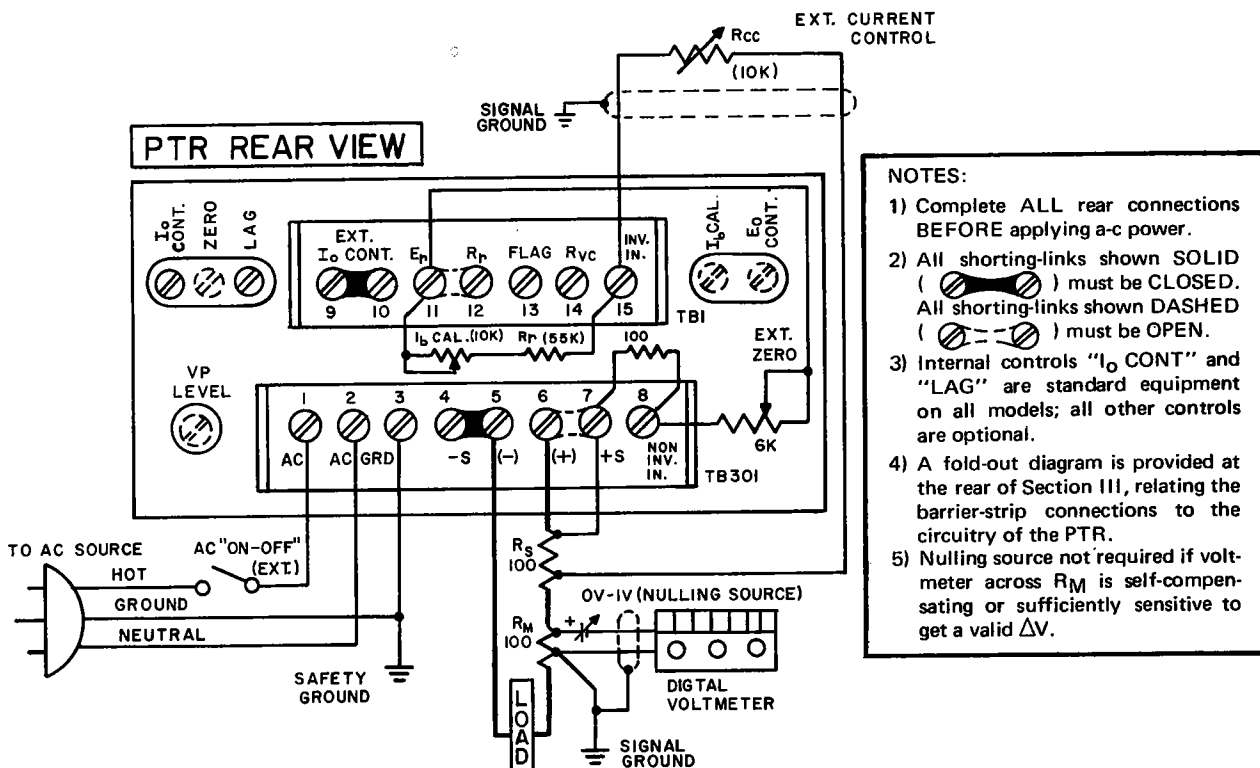

FIG. 3-10 CONNECTIONS FOR EXTERNAL SENSING AND RESISTANCE CONTROL ( $I_O$  max. = 10 mA).

### 3-50 EXTERNAL CURRENT SENSING AND VOLTAGE CONTROL

3-51 COMPONENT SELECTION. The use of increasingly smaller control currents and higher resistance values in the control circuit precludes the use of the previously illustrated control methods for output currents below about  $10\ \mu\text{A}$ . A method by which  $I_B$  is eliminated and replaced by an external control voltage is described in the following paragraphs.

3-52 The transfer function for output control by voltage was derived from FIG. 3-11 below and can be expressed by:

$$I_o = E_{CC}/R_S \quad (\text{Eq. 2}),$$

where:  $I_o$  = Desired Maximum Output Current  
 $E_{CC}$  = External Control Voltage  
 $R_S$  = Current Sensing Resistor

**NOTE:** This equation (Eq. 2) is derived from the equivalent diagram (FIG. 3-11), and is valid for the "zeroed" PTR.

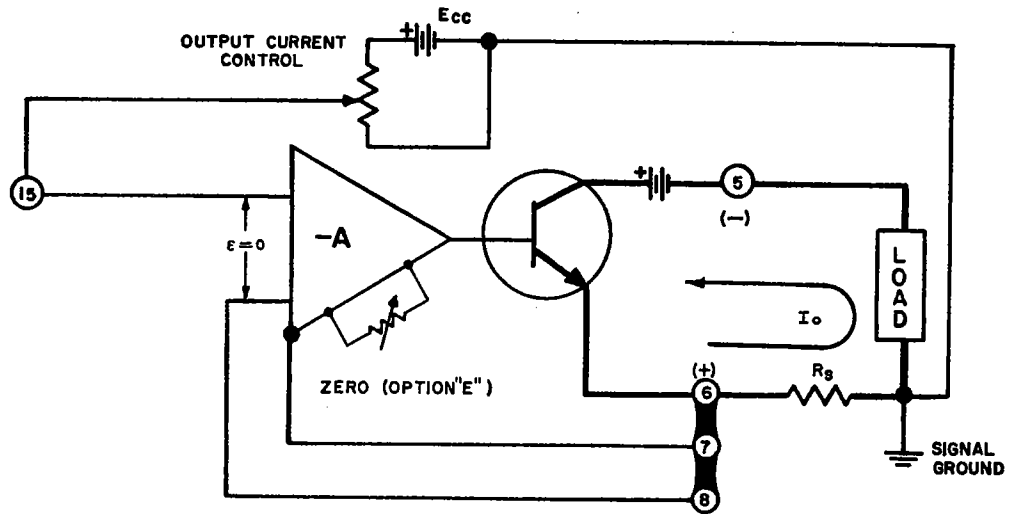

FIG. 3-11 EQUIVALENT DIAGRAM, PTR WITH EXTERNAL SENSING AND VOLTAGE CONTROL.

3-53 The circuit shown in FIG. 3-11 is suitable for output current from about 1 mA down to  $1\ \mu\text{A}$ . The necessary sensing resistors for various current ranges are given in the table for a control voltage ( $E_{CC}$ ) of 0–1 volt. For other control voltages, they can be calculated using the output equation (Eq. 2).

$I_o$ RANGE	$R_S$
0 – 1 mA	1 K ohm
0 – 100 $\mu\text{A}$	10 K ohm
0 – 10 $\mu\text{A}$	100 K ohm

3-54 The external control voltage ( $E_{CC}$ ) may simply consist of a potentiometer across a mercury cell (as indicated in FIG. 3-11) or it may be a controlled voltage source of your choice. The voltage source ( $E_{CC}$ ) must be stable, but its current capacity can be quite small, since it is connected to a virtually open circuit (provided the offsets are nulled or zeroed, as previously described in par. 3-45). If offset current zeroing is *not* used,  $E_{CC}$  must supply the offset current (typically  $0.1\text{--}0.5 \times 10^{-6}\ \text{A}$ ).

3-55 OUTPUT MEASUREMENTS. Stabilization measurements and output ripple checks can be performed by using the methods described in previous paragraphs (refer to par. 3-46 and 3-47).

3-56 EXAMPLE II. A PTR model is used to deliver stabilized output current from 0 to  $100\ \mu\text{A}$ . The actual connecting pattern for the circuit with external sensing and voltage control is illustrated in FIG. 3-12. Connect all components as shown in FIG. 3-12, locating the sensing resistor as close as possible to the power supply. The leads connecting the control voltage ( $E_{CC}$ ) must be shielded, with the shield (single-ended) connected to the common signal ground point. This ground point must be selected carefully, to avoid possible ground-loop effects. Note: PTR Power Supplies have an internal "signal ground" consisting of a resistor/capacitor, series connected from the negative output terminal to the chassis. This signal ground must be removed for the connection shown in FIG. 3-12. Refer to Section II (par. 2-8) of this manual.

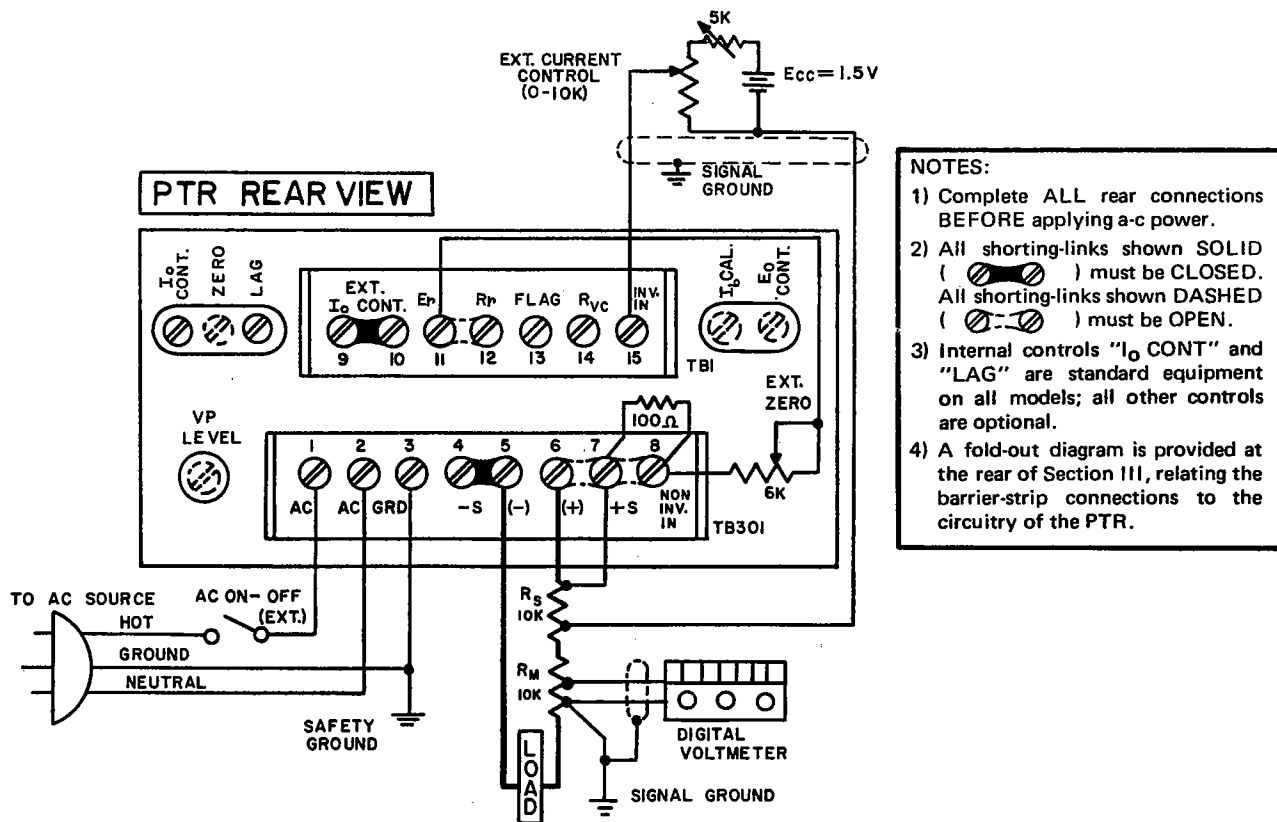



- NOTES:
- 1) Complete ALL rear connections BEFORE applying a-c power.
  - 2) All shorting-links shown SOLID (  ) must be CLOSED. All shorting-links shown DASHED (  ) must be OPEN.
  - 3) Internal controls "I<sub>o</sub> CONT" and "LAG" are standard equipment on all models; all other controls are optional.
  - 4) A fold-out diagram is provided at the rear of Section III, relating the barrier-strip connections to the circuitry of the PTR.

FIG. 3-12 CONNECTIONS FOR EXTERNAL SENSING AND VOLTAGE CONTROL ( $I_o$  max. = 100  $\mu$ A).

3-57 CALIBRATING THE OUTPUT. With the external control voltage ( $E_{CC}$ ) set to zero, the current output from the PTR should be zero. A small offset may, however, be observed on the output meter. This offset can be set to zero with the internal "zero" control ( $R_{12}$ —on PTR models with suffix "E") or by an external zero control consisting of a voltage divider, connected from the internal reference source ( $E_r$ ) to the noninverting input (refer to FIG. 3-12, delete external control if an "E" option PTR is used). The maximum output current value must be calibrated at the control voltage ( $E_{CC}$ ), or with an external rheostat, as shown in FIG. 3-12.

### 3-58 CURRENT CONTROL BY VOLTAGE (WITHOUT SENSING RESISTOR)

3-59 COMPONENT SELECTION. For applications where the *negative* power supply must be grounded, the output current of the PTR can be controlled by means of the internal reference source or an external control source, *without* the use of a sensing resistor. External component values are selected using the output current equation:

$$I_o = \frac{E_{in}}{R_{in}} - I_{io} \quad (\text{Eq. 3}),$$

NOTE:  $I_{io}$  is a small offset current which may be set to zero as shown in par. 3-63.

which is derived from the equivalent circuit shown in FIG. 3-13, and is valid for the "zeroed" PTR.

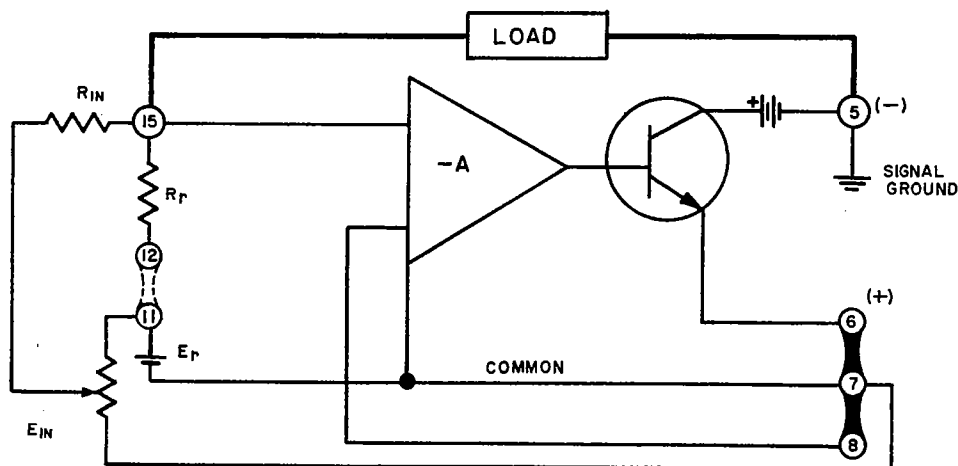
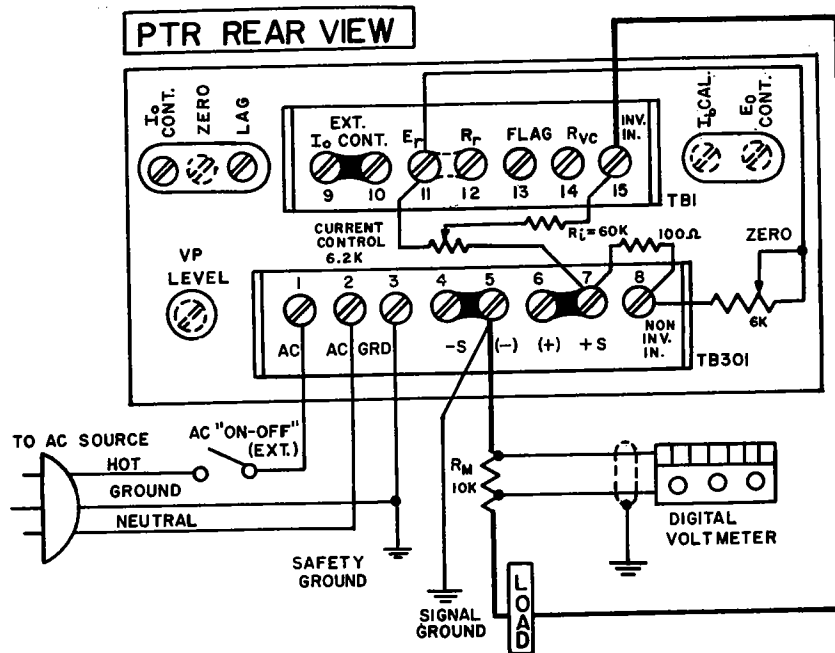

FIG. 3-13 EQUIVALENT DIAGRAM, PTR CURRENT CONTROL WITHOUT SENSING RESISTOR.

- 3-60 The circuit shown in FIG. 3-13 is suitable only for output currents to about  $100 \mu\text{A}$ , since the output current is derived from the internal reference source ( $E_r$ ) and *not* from the power supply, which acts as a "controller" only. The circuit is very useful, however, for applications requiring very small output currents, where the negative output side of the power supply (or the load) must be grounded.
- 3-61 The internal reference voltage ( $E_r$ ) is loaded with a 10 K ohm potentiometer to draw approximately 1 mA from  $E_r$ , while the control voltage ( $E_{in}$ ) is taken between its center tap and "common." The control voltage ( $E_{in}$ ) can now be varied between 0 and 6 volts. A series resistor ( $R_{in}$ ) of 60 K ohm, connected as shown (refer to FIG. 3-13) completes the control circuit. Stabilized output current in the range from 0 to  $100 \mu\text{A}$  can now be adjusted as the current control potentiometer is varied between its limits. The actual interconnections are illustrated in FIG. 3-14.
- 3-62 MEASUREMENTS. Stabilization measurements can be performed by connecting a current measuring resistor ( $R_M$  in FIG. 3-14) as shown.



**NOTES:**



- 1) Complete ALL rear connections BEFORE applying a-c power.
- 2) All shorting-links shown SOLID (  ) must be CLOSED. All shorting-links shown DASHED (  ) must be OPEN.
- 3) Internal controls "I<sub>o</sub> CONT" and "LAG" are standard equipment on all models; all other controls are optional.
- 4) A fold-out diagram is provided at the rear of Section III, relating the barrier-strip connections to the circuitry of the PTR.

FIG. 3-14 CONNECTIONS FOR CURRENT CONTROL BY VOLTAGE (WITHOUT  $R_g$ ).

- 3-63 CALIBRATING THE OUTPUT. With the external control voltage set to zero ( $E_{in} = 0$ ), the current output from the PTR Power Supply should be zero. A small, initial offset effect (the " $-I_{io}$ " term in Eq. 3) may, however, be observed on the monitoring output current meter. This offset can be set to zero with the circuitry shown in FIG. 3-14, or, if a PTR with "E" option is available, with the built-in "zero" control. The *maximum* output current can be calibrated by adjusting either " $R_i$ " or " $E_i$ " at the input.

**NOTE:** For assistance with special circuit problems, please contact your nearest Kepco Representative or the Kepco Engineering Applications Department at Flushing, New York.

### 3-64 PRECISION STABILIZED OUTPUT VOLTAGE PROGRAMMING

3-65 The PTR Power Supply, operating in the voltage mode, may be symbolically represented as a unipolar, inverting amplifier (refer to FIG. 3-15) with certain advantages and restrictions: Its high frequency response is limited due to a large output capacitor and its output is unipolar. Its low frequency response, on the other hand, includes d-c, and power gain is limited only by the power supply output rating. With these facts in mind, amplifier technology may be applied to power supply analysis.

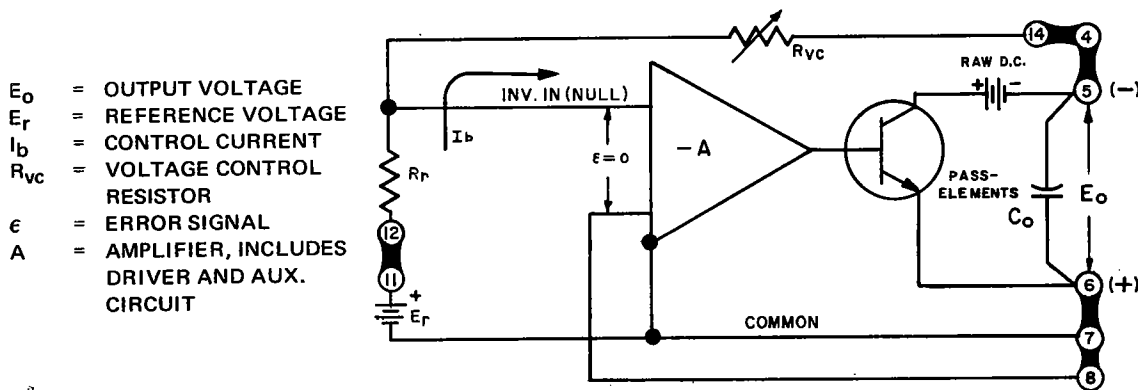

FIG. 3-15 EQUIVALENT DIAGRAM, PTR AS A POWER AMPLIFIER.

3-66 At the inverting input of the amplifier (Null Junction) a fixed reference voltage is compared to a portion of the stabilized output quantity by means of the feedback resistance ( $R_{vc}$ ). The "closed loop" feedback circuit, consisting of the reference source, feedback resistors and amplifier, tends to keep the error signal ( $\epsilon$ ) at zero, regardless of external or internal influences. At balance ( $\epsilon = 0$ ), the circuit equations for the voltage stabilizer may be written by referring to FIG. 3-15:

$$\left[ E_r/R_r = E_o/R_{vc} \right] \epsilon = 0, \text{ or, solving for "E}_o\text{":}$$

$$E_o = E_r/R_r (R_{vc}) \quad (\text{Eq. 4}), \text{ or (since } E_r/R_r = I_b\text{):}$$

$$E_o = I_b (R_{vc}) \quad (\text{Eq. 5})$$

where Eq. 4 or Eq. 5 represent the ideal transfer function of the power supply in the voltage mode.

3-67 VOLTAGE MODE PROGRAMMING. For the power supply in the voltage stabilized operating mode, the transfer function was shown to be:

$$E_o = E_r/R_r (R_{vc}) \quad (\text{Eq. 4}).$$

3-68 Inspection of this equation shows that a change in any of the three quantities on the right side will produce a change in the output voltage ( $E_o$ ). If, for example, a constant (d-c) control current is used ( $I_b = E_r/R_r$ ), the output voltage can be linearly controlled by  $R_{vc}$ :

$$E_o = I_b R_{vc} \quad (\text{Eq. 5}).$$

3-69 Making  $R_{vc}$  a variable resistance is the conventional manner of power supply voltage control. Leaving  $R_{vc}$  at a fixed value and substituting a variable control current source for the internal (fixed) control current ( $I_b$ ) constitutes another control method. Similarly, by substituting a variable voltage ( $E_i$ ) for the fixed reference source ( $E_r$ ), output control by voltage can be performed:

$$E_o = E_i \left( \frac{R_f}{R_i} \right) \quad (\text{Eq. 6}),$$

where  $R_f$  and  $R_i$  have been substituted for the internal voltage control and reference resistors ( $R_{vc}, R_r$ ). Practical examples of these control methods are presented in the following paragraphs.

### 3-70 PRECISION RESISTANCE PROGRAMMING

3-71 Resistance control of the output voltage is the standard method of power supply control and has been described in its simplest form in previous paragraphs (refer to par. 3-27). Many applications, however, require linear, precision control of the power supply output. For these applications, precise programming resistors (for example, precision decades) must be used and the power supply programming ratio (output volts per ohm of control resistance) must be calibrated.

3-72 VOLTAGE MODE. From an inspection of the equation for voltage output:

$$E_o = I_b (R_{vc}) \quad (\text{Eq. 5}),$$

we find that if  $I_b = 1 \text{ mA}$ , each 1000 ohms of control resistance ( $R_{vc}$ ) will produce 1 volt of output. Also, from (Eq. 5) if  $R_{vc} = 0$  (shorted out), the output voltage should be zero. Standard Kepco PTR Power Supplies (without suffix) have a control current ( $I_b$ ) slightly higher than 1 mA, and a small offset voltage ( $\approx -10 \text{ mV}$ ) in order to ensure full range output. Both inaccuracies, the slightly larger control current and the small negative offset voltage, may be precisely adjusted to provide a linear and highly accurate programming ratio. Kepco PTR Models with suffix "ER" (for example Model PTR 100-0.6ER) are equipped with zero and control current adjustments. On other models, these controls may be added by the user. Section V of this manual provides instruction for the installation of these components.

### 3-73 PROCEDURE, PRECISION PROGRAMMING RATIO CALIBRATION, VOLTAGE MODE

a) EQUIPMENT REQUIRED:

- 1) Precision digital or differential voltmeter (M1).
- 2) Precision resistor or resistor decade, depending on desired output: For each 1000 ohms, ( $R_{vc}$ ), 1 volt will be produced at the output.
- 3) Single pole, single throw (SPST) switch (S1).

b) Connect calibration setup as shown in FIG. 3-16 and connect the power supply to the a-c power input source.

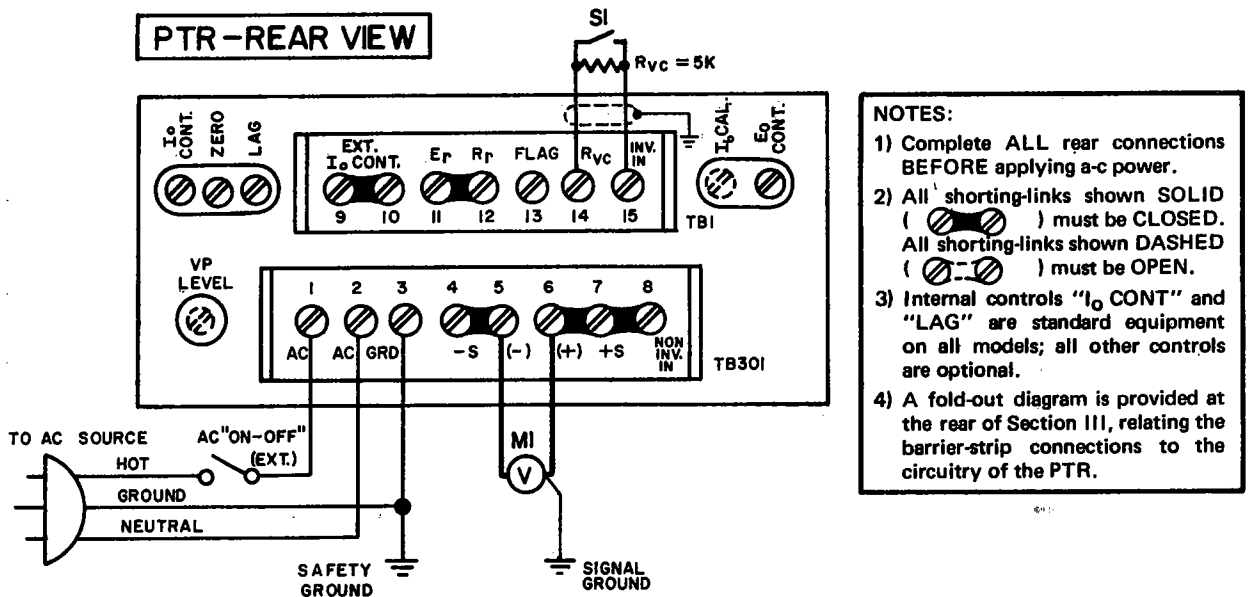

FIG. 3-16 CONNECTIONS FOR PROGRAMMING RATIO CALIBRATION.

- c) With S1 open, and  $R_{vc}$  set to 5 K ohms, for example, approximately 5 volts will be read out on M1. Turn "I<sub>b</sub> CAL." (R20) until *exactly* 5 volts are read out on M1.
- d) Close S1 and note deviation from true "zero" on M1 (approximately 2–8 mV negative). Adjust "zero" (R12) until *exactly* zero volts are read out on M1.
- e) Open S1 again and check the previously calibrated 5-volt reading. Repeat "zero" and "I<sub>b</sub> CAL." adjustments by alternately opening and closing S1 and correcting the calibrations to achieve the desired accuracy. Refer to FIG. 3-17 for a graph illustrating the programming ratio calibrating process.

- f) Depending on the quality of the programming resistors, a minor readjustment of the calibrating controls may be needed after all components have reached thermal equilibrium. Following final calibration, the voltmeter can be disconnected and operation can proceed.

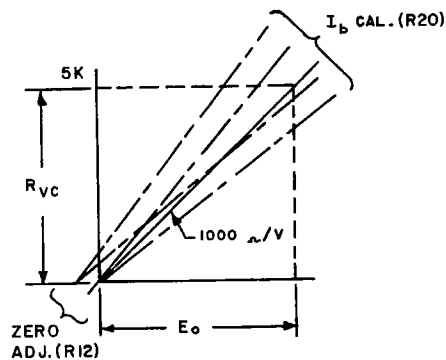

FIG. 3-17 PROGRAMMING RATIO GRAPH.

### 3-74 CONDUCTANCE PROGRAMMING

3-75 For applications requiring only a small output voltage change and for applications where the programming loop is likely to be opened (by switching or connectors), inverse resistance (conductance) programming can be used. This programming method can be applied in the voltage, as well as in the external current stabilizing mode. It is characterized in the voltage mode by the equation:

$$E_o = E_r (R_{vc}) (G), \quad \text{where: } G = \frac{1}{R_r + R_x} = \text{programming conductance or,}$$

$$E_o = \frac{E_r}{R_r + R_x} (R_{vc}) \quad (\text{Eq. 7})$$

$E_o$  = Output voltage  
 $E_r$  = Reference voltage  
 $R_{vc}$  = Control resistance  
 $R_r$  = Reference resistance  
 $R_x$  = Programming resistor

3-76 Since  $E_r/R_r = I_b$  and  $E_o = I_b R_{vc}$ , the output voltage varies directly as  $I_b$  changes. Changing  $I_b$  with the help of an additional resistor in series with  $R_r$  results in an inversely proportional change of  $I_b$  since now:

$$I_b = \frac{E_r}{R_r + R_x}$$

3-77 This method of output voltage adjustment is therefore referred to as **Conductance Programming**. It can be seen from an inspection of the equation for the control current ( $I_b$ ) that, if the programming resistor ( $R_x$ ) should open accidentally, the total resistance ( $R_r + R_x$ ) would go to infinity and  $I_b$  to zero. Consequently the output would become zero. A practical example should illustrate component selection for conductance programming.

3-78 PROCEDURE (Refer to FIG. 3-18)

Example:  $E_o$  desired = 3 to 5 volts.

- a) Select  $R_{vc}$  for maximum desired output voltage  $E_o$ .

$$R_{vc} = \frac{E_o}{I_b}, \quad R_{vc} = \frac{5V}{1 \text{ mA}} = 5 \text{ K ohms.}$$

- b) A change of  $E_o$  to 3 volts requires a bridge current reduction of:

$$\Delta I_b = \frac{\Delta E_o}{R_{vc}} = \frac{2 \text{ volts}}{5 \text{ K ohms}} = 0.4 \text{ mA.}$$





3-82 Component values must be selected to suit each individual application, using the programming equations above. The process will be illustrated by a practical example. In general, some basic facts should be kept in mind:

- The output quantities ( $E_o$ ,  $I_o$ ) are limited by the maximum rating of the power supply model to be programmed. If the internal current control ( $I_o$  CONT) is set to a lower limit, *this* current value constitutes the maximum programmable output current. For models equipped with overvoltage crowbars (suffix "VP"), having the level control "VP" set to a lower than maximum output voltage value, *this* voltage value constitutes the maximum programmable output voltage.
- The input signal ( $E_i$ ) must be a high-quality source, if high-quality output is expected. Errors (drift with temperature and time, instability, nonlinearity) will be amplified with the signal!  $E_i$  should be able to deliver between 0.01 mA and 10 mA of programming current. These limits are dictated by the requirement of a reasonable signal/noise ratio on one hand and by the need to limit dissipation in the feedback resistor on the other.
- Feedback and input resistors ( $R_f$ ,  $R_i$ ) should be selected for stability (low temperature coefficients) rather than accuracy, since part of either resistance can be made variable to compensate for tolerances. A wide safety margin should be allowed when determining the wattage rating of the programming resistors (at least 10-times the actual *calculated* wattage should be used).

3-83 Actual component values are determined by the signal/source output level and the desired power supply output. Example: A Model PTR 40-1.4 is to be voltage programmed by an external signal source, delivering a positive-going sawtooth wave with an amplitude of 10 volts at 5 mA (for instance, by a KEPCO Model FG 100A Function Generator). A power supply output of 40 volts at maximum rated current is desired (VOLTAGE MODE OPERATION).

- The basic equation for voltage output is used to calculate the necessary components:

$$E_o = E_i (R_f/R_i) \quad (\text{Eq. 6})$$

Since a voltage gain of  $E_o/E_i = 4$  is needed, the equation (Eq. 6) shows that the ratio  $R_f/R_i$  must also equal 4. If we decide to use a control current of 5 mA,  $R_i$  can be calculated from:

$$E_i/R_i = I_b = 5 \text{ mA}, \quad R_i = 10\text{V}/5 \text{ mA} = 2 \text{ K ohm.}$$

Therefore  $R_f$  must be:  $4 \times 2 \text{ K} = 8 \text{ K ohm.}$

Power dissipated in  $R_f = 40\text{V} (0.005) = 0.2\text{W}$  (use 2W).

Power dissipated in  $R_i = 10\text{V} (0.005) = 0.05\text{W}$  (use 0.5W).

3-84 Connect the selected components and the signal source as illustrated in FIG. 3-19. Use shielding as indicated and connect (single-ended) to the chosen signal ground.

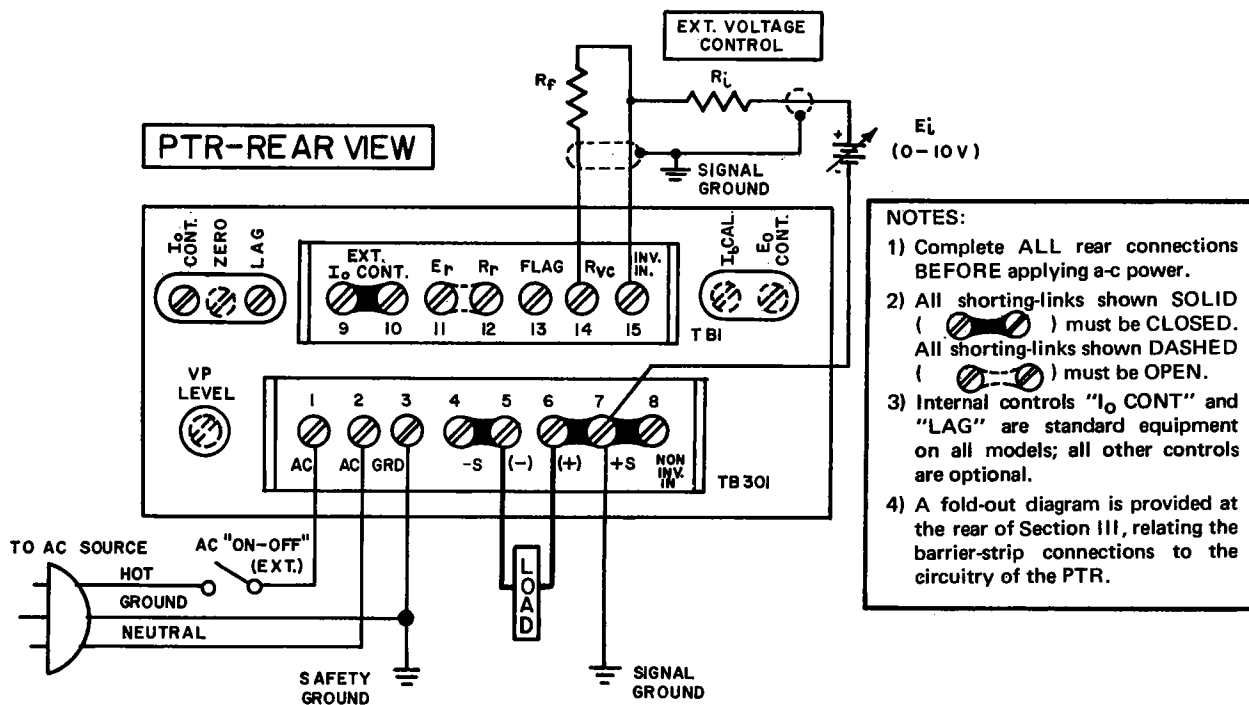

FIG. 3-19 CONNECTIONS FOR VOLTAGE PROGRAMMING IN THE VOLTAGE MODE.

### 3-85 SERIES CONNECTION WITH KEPCO POWER SUPPLIES

3-86 GENERAL. Kepco Power Supplies can be series connected for increased voltage output, provided the specified limits for "Isolation Voltage" are not exceeded. Two basic series-connection methods are generally used, the "Automatic" series connection, as illustrated in FIG. 3-20 and the "Master/Slave" connection, shown in FIG. 3-21. The basic difference between these two alternate methods lies in the manner of the output control. While in the "Automatic" connection, the outputs of both supplies may be controlled *individually*. In the "Master/Slave" connection, control is exercised from the "master" supply alone, while the "slave" supply follows the master command in a ratio which may be predetermined by the user. The latter method of series operation is therefore frequently termed "Automatic Tracking."

#### 3-87. PROCEDURE FOR AUTOMATIC SERIES CONNECTION

- Connect load as shown in FIG. 3-20. Keep voltage drop in load wires as low as practical by using heavy gauge wire.
- Remove jumpers as shown and connect error sensing leads. These leads should also be as heavy as practicable, and should be twisted and shielded.
- Turn supplies on and adjust voltage on both controls as required.

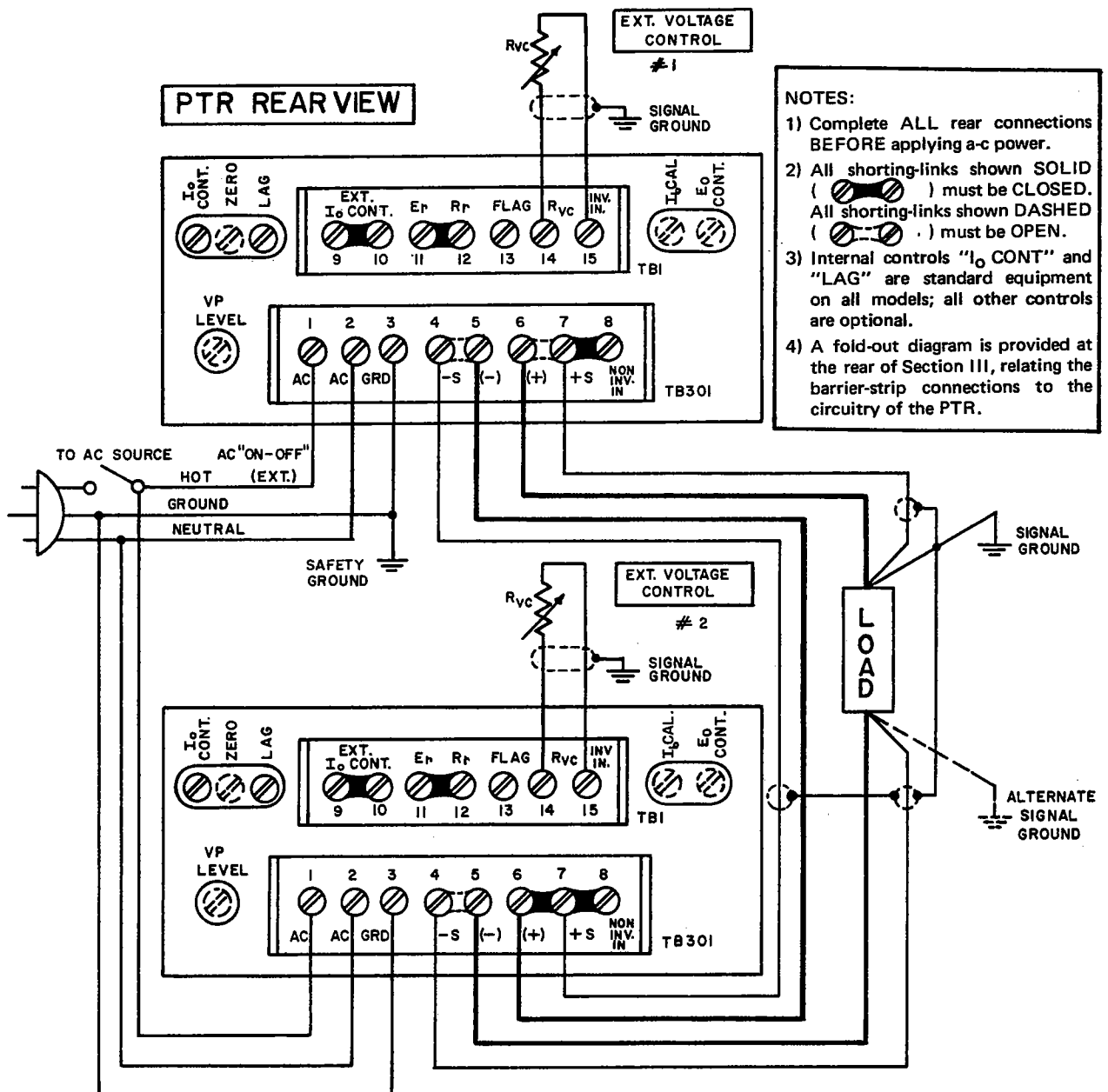

FIG. 3-20 "AUTOMATIC" SERIES CONNECTION.

3-88 The "Master/Slave" series connection method is illustrated in FIG. 3-21. As seen from the figure, the reference voltage ( $E_r$ ) of the "slave" supply is disconnected and its input or null junction is connected to the output of the "master" supply via the tracking resistor ( $R_t$ ). The "slave" supply output is thus completely dependent on the "master" output voltage:

$$E_{os} = E_{om} \frac{R_{vcs}}{R_t}$$

where:  $E_{om}$  = Output Voltage, Master  
 $E_{os}$  = Output Voltage, Slave  
 $R_t$  = Tracking Resistor  
 $R_{vcs}$  = Voltage Control Resistance, Slave

3-89 As evident from the equation above, if the tracking resistor ( $R_t$ ) value is equal to that of the voltage control resistor of the "slave" supply ( $R_{vcs}$ ), a tracking ratio of 1:1 is achieved and the output of the "slave" will equal that of the "master." If a single load is connected to the series "Master/Slave" combination, twice the "master" output voltage is applied to it. If separate loads are connected, identical voltages are applied to the individual loads.

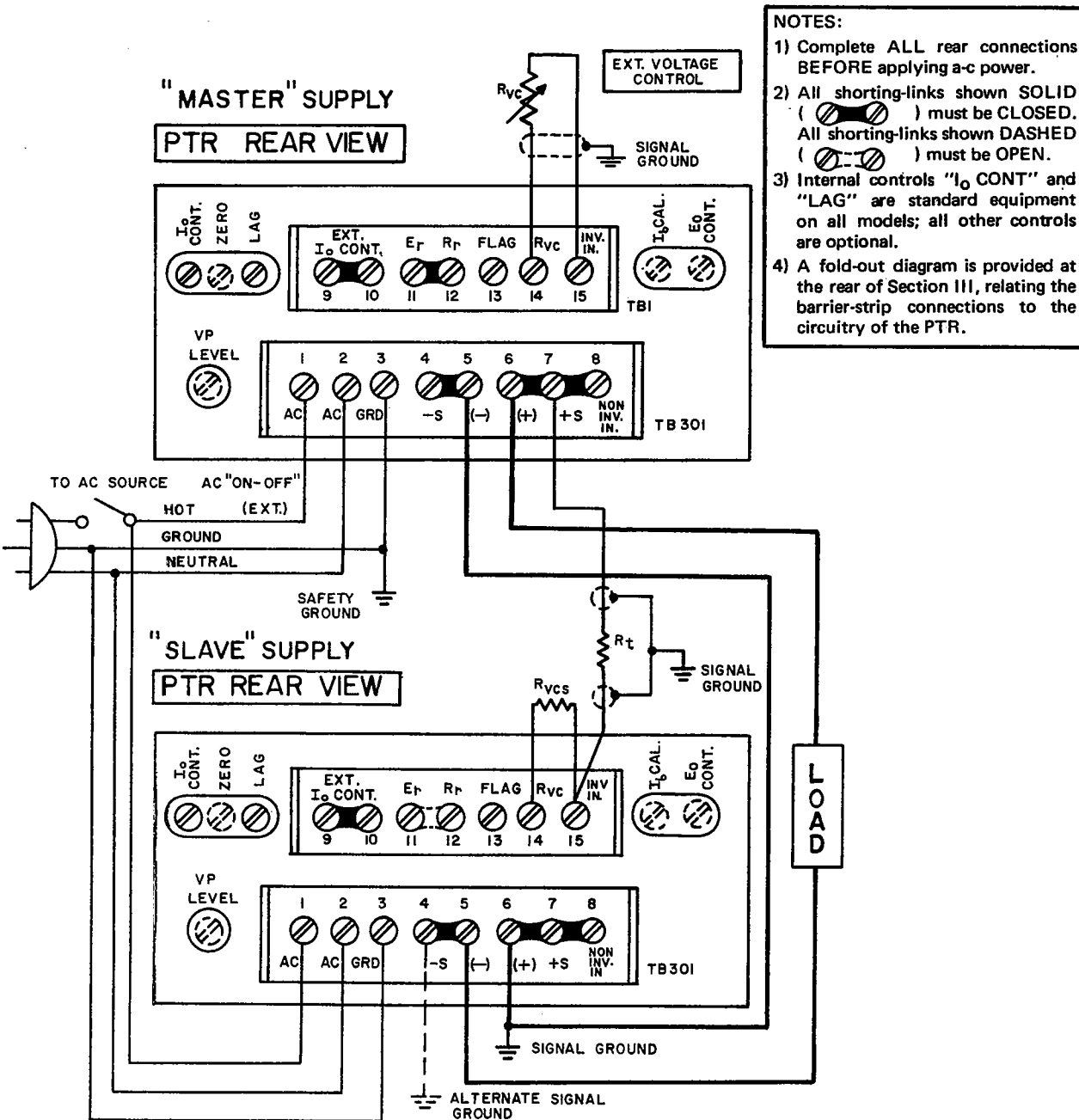

FIG. 3-21 "MASTER/SLAVE" SERIES CONNECTION.

3-90 The ratio  $E_{OS}/E_{OM}$  can be readily changed if the application so requires by simply altering the value of either  $R_{VCS}$  or  $R_t$ . In practice, the tracking resistor ( $R_t$ ) is selected for the desired tracking ratio. For a 1:1 ratio,  $R_t = R_{VCS}$ ; for a 1:2 ratio,  $R_t = 1/2 R_{VCS}$ , etc.

### 3-91 PROCEDURE FOR MASTER/SLAVE SERIES CONNECTION

- a) Connect load as shown in FIG. 3-21. Keep voltage drop in the load wires as low as possible by using heavy gauge wire.
- b) Remove jumper links as shown (FIG. 3-20) and connect error-sensing leads if remote sensing is desired. Sensing leads should be twisted and shielded.
- c) Select value of the tracking resistor ( $R_t$ ) and connect with shielded wire as shown (FIG. 3-21).
- d) Turn supplies "on," and adjust output voltage on the "master" voltage control as desired.

### 3-92 PARALLEL OPERATION OF KEPKO POWER SUPPLIES



Special precautions are required when paralleling *more than two* Kepco PTR Power Supplies, or when "redundant" operation is required. Please contact the KEPKO APPLICATIONS ENGINEERING DEPARTMENT for more information.

3-93 Kepco Power Supplies may be operated in parallel for increased load current output. Two parallel connection methods are generally used, the "automatic" parallel connection as shown in FIG. 3-23 and the "Master/Slave" connection as illustrated in FIG. 3-24. The difference between these two alternate methods lies in the manner in which the output is controlled. While in the "automatic" parallel connection the output is set individually, in the "Master/Slave" connection control is exercised from the "master" supply alone. In effect, output current sharing must be individually adjusted with the "automatic" method, and is inherent with the "Master/Slave" connection

3-94 "AUTOMATIC" PARALLEL OPERATION. Two Kepco Power Supplies are connected with their outputs in parallel as shown in FIG. 3-23. Each supply is set approximately to the desired output voltage, with its respective Current Control at its maximum clockwise position. After turn-on, one of the supplies (#1) in FIG. 3-23 will be at a slightly higher voltage than the other (supply #2). Consequently, supply #1 will operate in the *current mode* and deliver all the load current up to the setting of its current control. As the load current demand is increased beyond this limit of supply #1, supply #2 takes over and operating in the *voltage mode*, delivers the additional current. The current control adjustment of supply #1 can now be decreased, so that approximately equal current sharing is obtained. FIG. 3-22 shows in form of a diagram, how the two supplies operate in parallel, with their respective current controls set to the maximum clockwise position (105%  $I_O$  max.). It will be obvious from the diagram, that the areas of load regulation are within the output current band of supply #2 only. Therefore, load regulation *cannot be measured from zero to twice the load current* for example, but *only within the individual load current band of supply #2*. Error sensing, as described in par. 3-21, (from supply #2, operating in the *voltage mode*) may be used if precise regulation at the load is required.

### 3-95 PROCEDURE FOR "AUTOMATIC" PARALLEL CONNECTION (refer to FIG. 3-22)

- a) Connect units as shown in FIG. 3-23. Open S1 and connect to line. Close a-c source switch.
- b) Adjust both units to the approximate output voltage desired.
- c) Close S1. Observe load current meters M1 and M2. Adjust current control ( $I_O$  CONT) on the unit showing the higher current on its load current meter. Turn current control counterclockwise until currents on M1 and M2 are approximately equal.
- d) If error sensing is used, check flag signal to be sure that the unit used for error sensing is in *voltage mode* (see voltmeter "V" in FIG. 3-23).

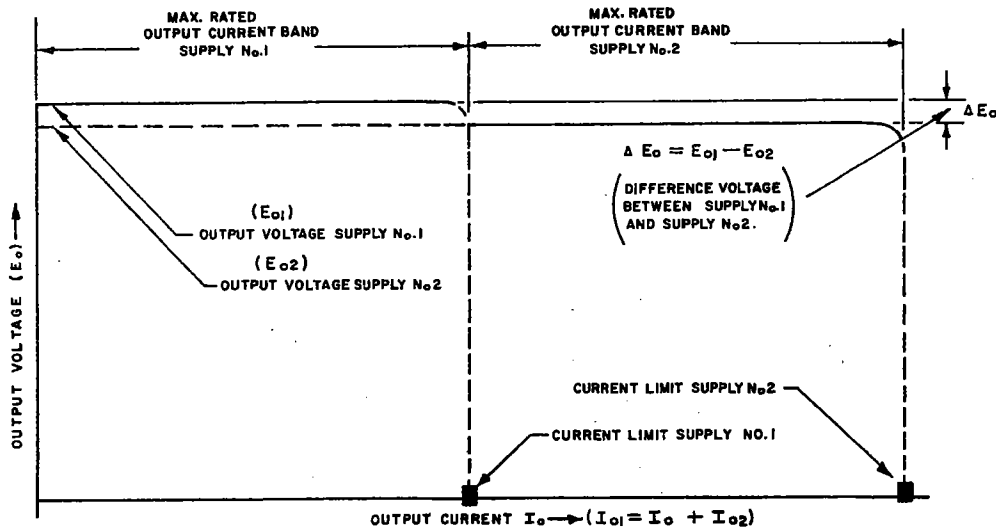

FIG. 3-22  $E_o/I_o$  CHARACTERISTIC OF TWO PARALLEL POWER SUPPLIES.

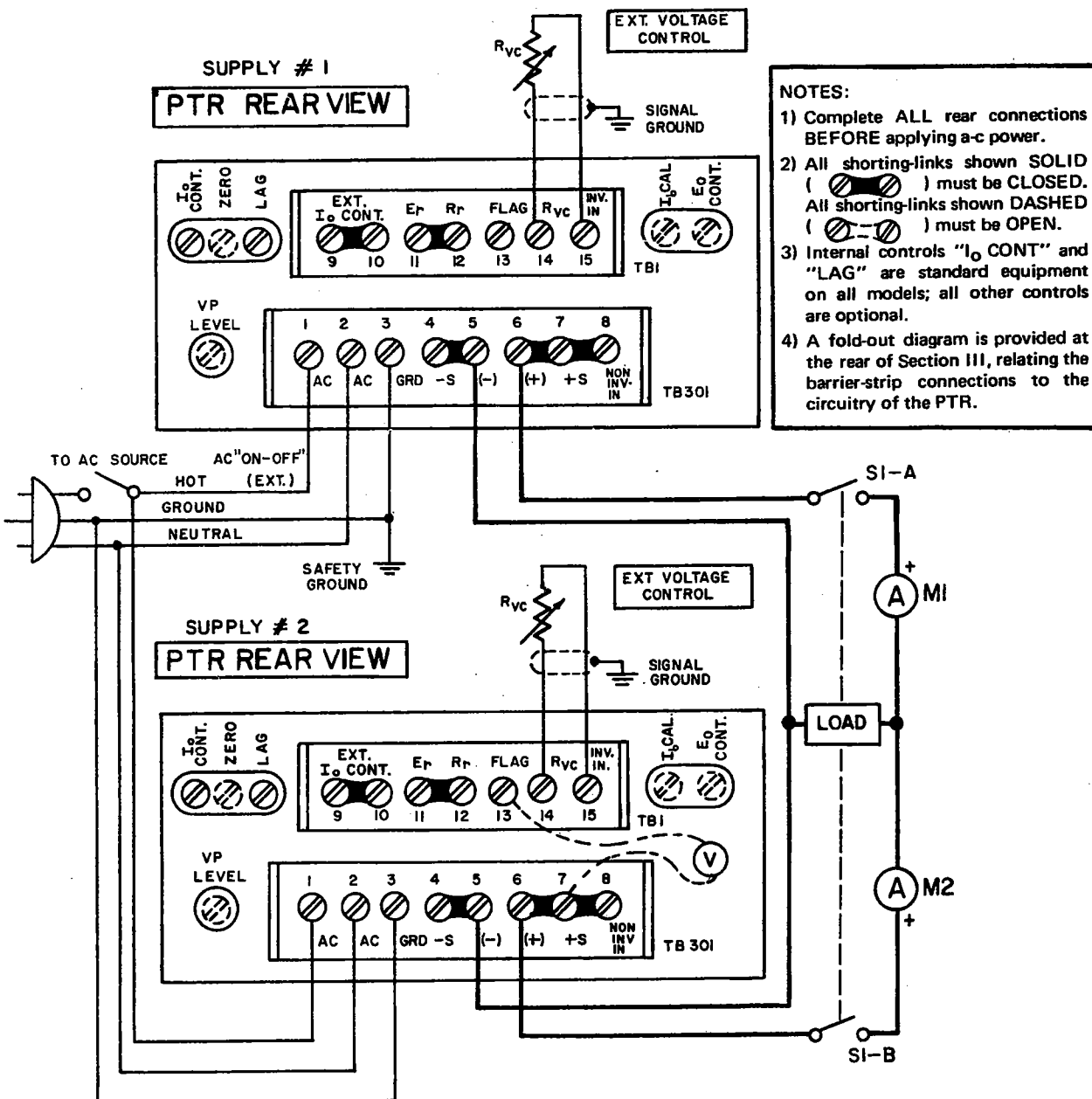
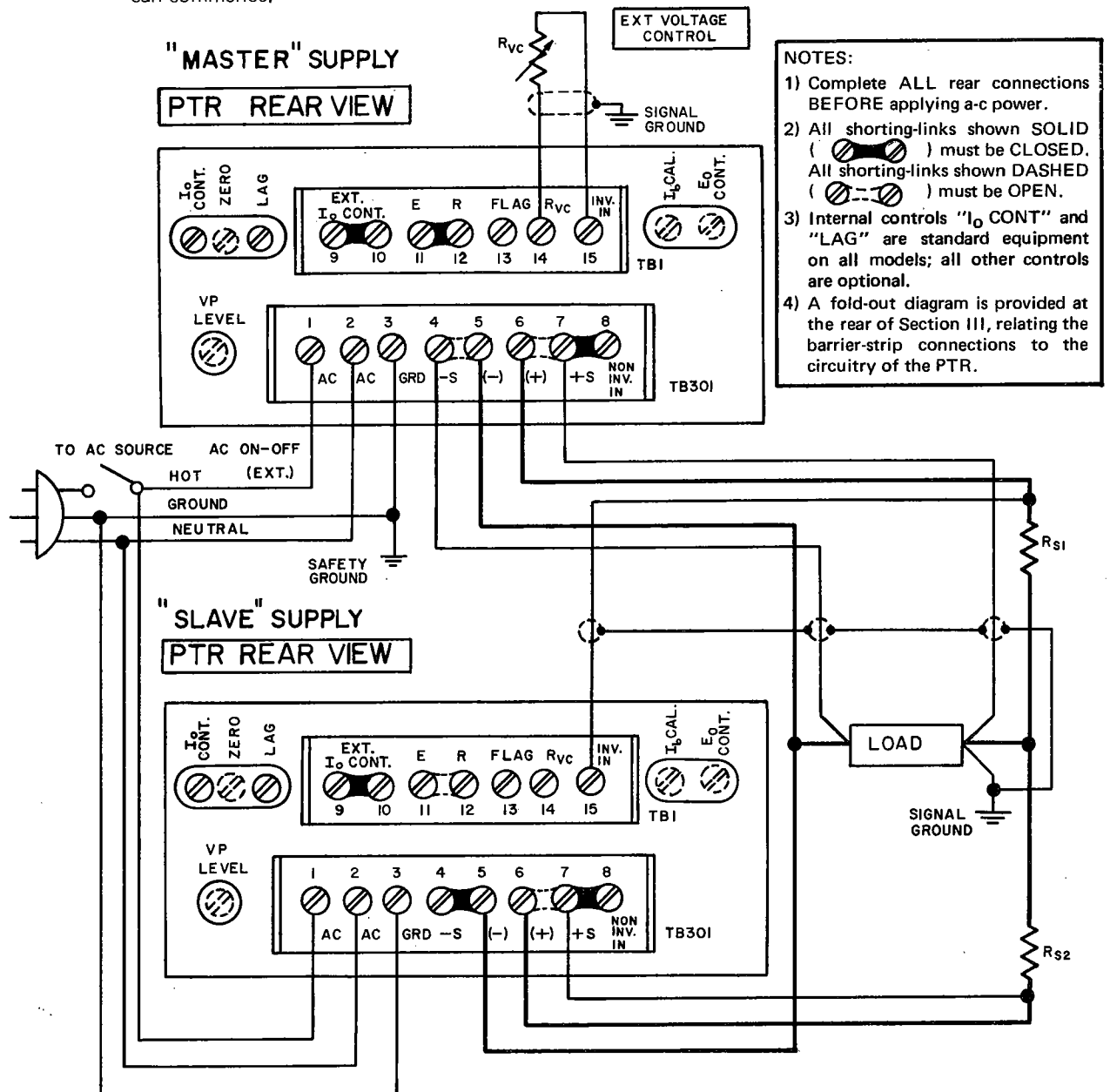

FIG. 3-23 "AUTOMATIC" PARALLEL CONNECTION.

3-96 MASTER/SLAVE PARALLEL OPERATION. Kepco Power Supplies may be paralleled if the output current from a single supply is not sufficient for the application at hand. With the parallel connection shown in FIG. 3-24, the total output current of the parallel supplies may be controlled from a single "master" supply. To operate the parallel supplies in the "Master/Slave" connection "sharing" resistors of equal value must be selected ( $R_{S1}$ ,  $R_{S2}$  in FIG. 3-24 such that the voltage drop across them is about 0.1 to 0.25 volts at the output current of interest. The *sum* of the voltage drops across the load wire with the sensing resistor in series should *never exceed 0.5 volts* at the maximum desired operating current. If "sharing" resistors of the proper value are not available, the resistances of the load wires may be used to establish the necessary voltage drops. In this case, the load wires should be trimmed such that *equal voltage drops* are established in the lead from the "master" and from the "slave" supply. Load wires should in general be of as heavy a wire gauge as practicable. Twisting of the load wires, as well as of the error sensing leads from the "master" supply (although *not* shown in FIG. 3-24) is recommended.

3-97 PROCEDURE FOR "MASTER/SLAVE" PARALLEL CONNECTIONS

- Select external current-sensing resistors ( $R_{S1}$ ,  $R_{S2}$ ), or trim load wires to equal lengths.
- Connect supplies as shown in FIG. 3-24, keeping load and error-sensing leads as short as possible. Use shielded wire for the connection from terminal (6) of the "master" to terminal (15) of the "slave" unit.
- Connect supplies to common a-c power line and use common power switching as shown.
- Set the current controls ( $I_O$  CONT) of both supplies to their maximum clockwise position. After turn-on, output voltage can be adjusted on the voltage control of the "master" supply and operation can commence.





- NOTES:
- Complete ALL rear connections BEFORE applying a-c power.
  - All shorting-links shown SOLID (  ) must be CLOSED. All shorting-links shown DASHED (  ) must be OPEN.
  - Internal controls "I<sub>O</sub> CONT" and "LAG" are standard equipment on all models; all other controls are optional.
  - A fold-out diagram is provided at the rear of Section III, relating the barrier-strip connections to the circuitry of the PTR.

FIG. 3-24 "MASTER/SLAVE PARALLEL CONNECTION."

### 3-98 VOLTAGE PROGRAMMING WITH NONINVERTING INPUT

3-99 A useful property of a noninverting amplifier is the large input impedance developed by negative feedback. Since the noninverting input of the error amplifier is made available at the barrier-strip of the PTR Power Supply, it can be used for applications where the programming source impedance is high and large control currents cannot be drawn. Since the high input impedance of the noninverting configuration does not depend upon the magnitude of the feedback components, the latter may be selected quite low, in a region of values, where high quality, stable components are readily available. The *common-mode voltage limit* must be observed for the amplifier used in the PTR Power Supplies (typically 8 volts) since excessive input voltages will saturate the amplifier. The approximate transfer function for noninverting operation may be expressed by:

$$E_o = E_i \left( \frac{R_{vc}}{R_i} + 1 \right) \text{ (Eq. 8).}$$

3-100 For exact equations, limitation and compensation circuits, please refer to the standard literature for operational amplifiers. A simple example illustrating the use of the noninverting input is given below:

3-101 A Model PTR 40-1.4 is available to produce a 2:1 replica of a -5V reference source. Referring to the transfer function given above, we must have:  $E_o = 2 E_i$ ; i.e., the ratio  $R_{vc}/R_i$  must equal unity or  $R_{vc} = R_i$ . If two 1 K ohm wirewound resistors are available, the output current loss of the PTR Power Supply due to the feedback current is negligible:

$$I_{\text{feedback}} = \frac{E_o}{R_{vc} + R_i} = \frac{10V}{1K + 1K} = 5 \text{ mA.}$$

No appreciable current is drawn from the reference source (except leakage current in the nanoampere range), but full load current (1.4A less 5 mA) can be drawn from the Model PTR 40-1.4 at twice the reference potential ( $2 \times 5V = 10V$ ). The appropriate rear barrier-strip connections are shown in FIG. 3-25.

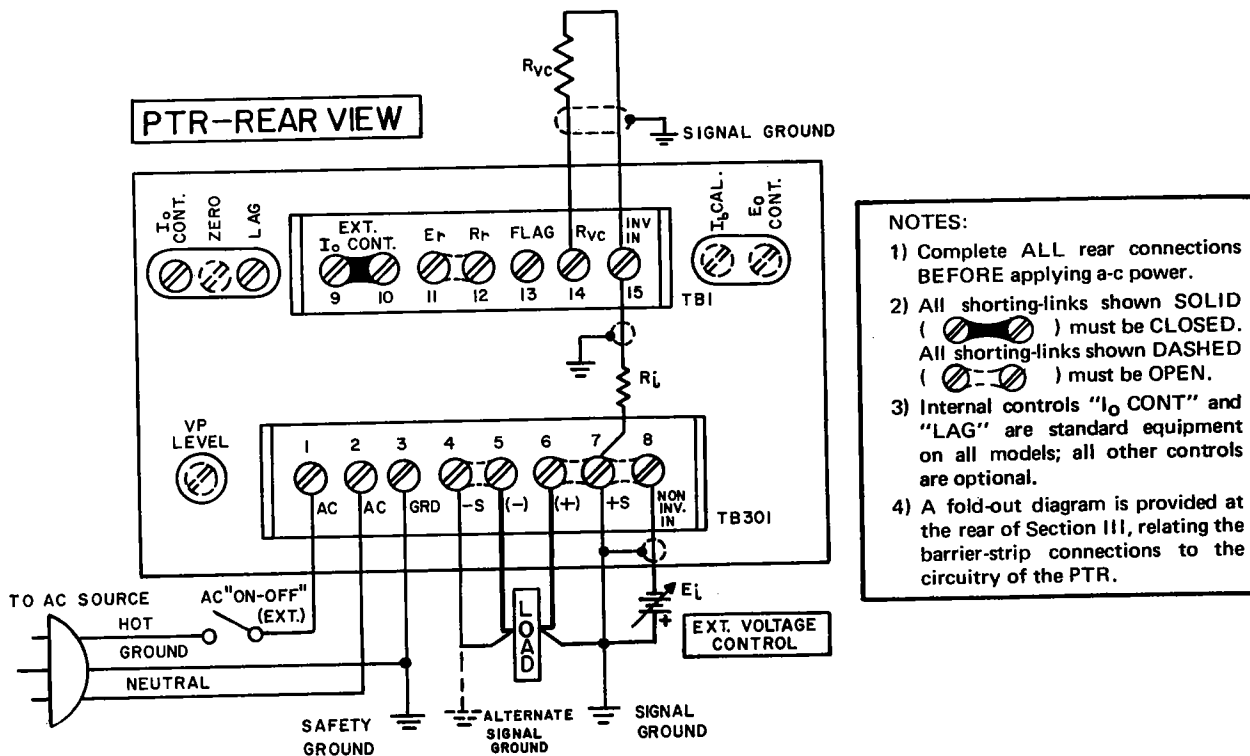

FIG. 3-25 CONNECTIONS FOR NONINVERTING PROGRAMMING.



### 3-102 FLAG SIGNAL

3-103 A "Flag Signal" is provided at terminal (13) which indicates the mode of operation of the PTR. When the *voltage-mode* amplifier ( $A_V$ ) is in control, the flag signal will be *zero* or slightly negative [with reference to terminal (7)]. When the *current-mode* amplifier ( $A_I$ ) is controlling the output, the flag signal will be *+5 volts d-c* or more. The source impedance of the flag signal is  $\approx 5$  K ohms. This signal may be used to trigger a remote alarm for feedback to computer control and many other automatic process operations. It is also highly useful in determining the mode of operation when two or more PTR's are autoparalleled (see par. 3-94).

3-104 It must be borne in mind that when the unit is used in the *external* current mode,  $A_V$  becomes the *current-control* amplifier. In this case, the flag signal will only go high when the "back-up" current limit is in control.

It is therefore recommended, when using the power supply in the external current mode, to set the built-in current control ( $I_O$  CONT-R9), acting now as the "back-up" current limit, to a point slightly beyond the maximum desired output current. The flag signal output can thus be used to indicate an overcurrent condition.



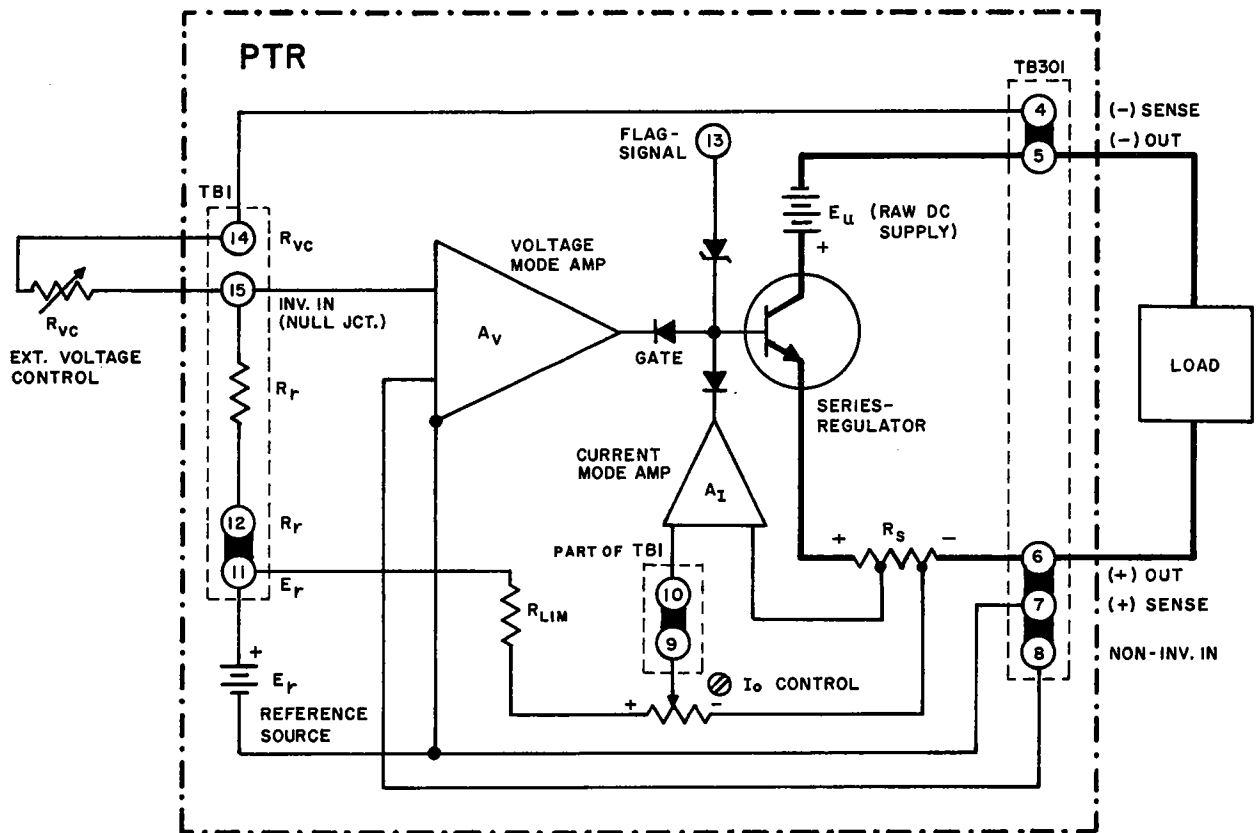

NOTES:

- 1) Encircled numbers [0] refer to terminals on barrier-strips TB1 and TB301.
- 2) Diagram shows PTR connected for standard operation, without error sensing.

FIG. 3-26 SIMPLIFIED DIAGRAM, KEPCO PTR MODELS.

