

OPERATOR'S MANUAL

FPD 50 WATT POWER SUPPLY

Flat Pack Single Output DC to DC Converter
50 Watts Output
12 Vdc Nominal Input

KEPCO INC.
An ISO 9001 Company.

MODEL FPD 50W-12V POWER SUPPLY

IMPORTANT NOTES:

- 1) This manual is valid for the following Model and associated serial numbers:

MODEL	SERIAL NO.	REV. NO.
-------	------------	----------
- 2) A Change Page may be included at the end of the manual. All applicable changes and revision number changes are documented with reference to the equipment serial numbers. Before using this Operator's Manual, check your equipment serial number to identify your model. If in doubt, contact your nearest Kepco Representative, or the Kepco Documentation Office in New York, (718) 461-7000, requesting the correct revision for your particular model and serial number.
- 3) The contents of this manual are protected by copyright. Reproduction of any part can be made only with the specific written permission of Kepco, Inc.

Data subject to change without notice.

©2007, KEPCO, INC.
P/N 243-0792



KEPCO, INC. • 131-38 SANFORD AVENUE • FLUSHING, NY. 11355 U.S.A. • TEL (718) 461-7000 • FAX (718) 767-1102
email: hq@kepcopower.com • World Wide Web: <http://www.kepcopower.com>

**FLAT PACK
Single Output
DC to DC Converters**

I INTRODUCTION:

SCOPE OF MANUAL: This instruction brief contains information for the installation and operation of the Kepco FPD 50 Watt DC to DC Converter Series of switching power supplies. For further operating and service information for the FPD 50 Watt DC to DC Converter Series contact your Kepco Representative directly, or write to Kepco, Inc., 131-38 Sanford Avenue, Flushing, New York 11352 U.S.A.

DESCRIPTION: The Kepco FPD 50 Watt DC to DC Converter Series consists of four switching power supplies, having a nominal 12 Vdc input and different DC output voltages, rated as listed in Section II. FPD 50 Watt Converter switching power supplies have similar electrical specifications, except for the output ratings. They are low-dissipative stabilizers, using pulse-width modulation to control the output. The units feature input/output isolation and remote ON/OFF. Remote ON/OFF is accomplished by an isolated TTL level signal that may use either mechanical or solid state closure for turn-off. All models are guaranteed for one year when operated within the specifications given herein.

II MODELS:

The following specifications apply to the power supply models listed below:

MODEL	INPUT	OUTPUT
FPD 5-10-12	12 Vdc	5 Vdc 10A
FPD 12-4.2-12	12 Vdc	12 Vdc 4.2A
FPD 15-3.4-12	12 Vdc	15 Vdc 3.4A
FPD 24-2.1-12	12 Vdc	24 Vdc 2.1A

NOTE: Normal conditions are nominal input, nominal output, and 25 degrees C.

III SPECIFICATIONS:

Nominal Input Voltage:	12 Vdc
Input Voltage Range:	9-18 Vdc
Input Current:	5.6A Typical, 8.0A Maximum at 12 Vdc Input
Brownout Voltage:	8 Vdc
Efficiency:	80 percent Typical
Switching Frequency:	300 kHz Typical
Circuit Type:	Forward Converter
Soft Start Circuit:	None
Input Fuse:	15-20A Recommended

IV OUTPUT SPECIFICATIONS:

MODEL	FPD 5-10-12	FPD 12-4.2-12	FPD 15-3.4-12	FPD 24-2.1-12
Output Voltage Nominal	5V	12V	15V	24V
Output Current Nominal	10A	4.2A	3.4A	2.1A
Output Power Maximum	50W	50.4W	51W	50.4W
Voltage Adjustment Range	4.5~5.5V	10.8~13.2V	13.5~16.5	21.6~26.4
Ripple, Maximum 0-50 Degrees C 10-100 % Load	150mV p-p	200mV p-p	200mV p-p	200mV p-p
Noise, DC to 50 MHz, Maximum 0-50 Degrees C 10-100% Load	250mV p-p	300mV p-p	300mV p-p	400mV p-p
Overcurrent Setting Square Wave Characteristic	10.3~ 13.5A	4.3~ 5.7A	3.5~4.5A	2.2~2.9A
Overvoltage Setting Shut Down Characteristic	5.5~ 6.9V	13.7~15.7V	17.0~19.0V	27.0~30.5

Source Effect	1% Typical — 2% Maximum (9-18V Input)
Load Effect	1% Typical — 2% Maximum (10-100% Load)
Temperature Effect	1% Typical — 2% Maximum (0-70 Degrees C)
Combined Effect	3% Typical — 6% Maximum (Source, Load, Temperature)
Time Effect	0.1% Typical — 2% Maximum (0.5~8 Hours at 25 Degrees C)
Recovery Characteristics 50 to 100% Load Change	Less Than ± 4 Percent Excursion . Recovery to within 1 percent in less than 1ms (tr, tf of load change $\geq 50 \mu\text{s}$ at 12V Input (See Figure 4)

V GENERAL SPECIFICATIONS

SPECIFICATIONS	CONDITIONS	
Temperature	Operating 0~70 Degrees C Storage - 40 ~ 105 Degrees C	See Figures 7A and 7B
Humidity	Operating and Storage: 5 ~ 95 percent RH	Wet bulb temperature < 35 Degrees C - No Condensing
Vibration	5 ~10Hz — 10mm Amplitude 10 ~55Hz — 5G Acceleration	Non-Operating 1 Hour on each 3 axis
Shock	50 G 11 \pm 5 ms Pulse Duration	Non-Operating, 1/2 Sine Pulse - 3 Shocks each axis
Withstand Voltage	Input-Output: 500 Vdc 1 minute Input-Ground: 500 Vdc 1 minute	at 25 Degrees C 65 percent RH
Isolation Resistance	Output-Ground: >100M ohm, 500 Vdc	
Dimensions	4.53 (115) x 2.3 (58) x 0.52 (13.2)	See Outline Drawing, Figure 1
Weight	5.29 oz. (150 grams) Maximum	
Cover Material	Plastic (UL94V-O) With Aluminum Base	

VI REMOTE ON/OFF:

The following input signals applied to the RC terminal, control the output voltage (see Figure 3).

REMOTE CONTROL INPUT SIGNAL	POWER SUPPLY OUTPUT
TTL H Level 2.4 ~5.0V or Open	ON
TTL L Level 0 ~0.4V (Short Circuit Current 6 mA Maximum)	OFF

- NOTE:**
1. The RC terminal should be left open for normal operation.
 2. The rise and fall time of the input waveform to the RC terminal should be 2 msec maximum.
 3. The input circuit to the RC terminal should be designed with a photo coupler or relay (see Figure 3)
 4. The RC control circuit is on the primary side

VII REMOTE SENSE:

Two terminals are provided for remote error sensing (see Figure 2). Remote error sensing can compensate for load wire voltage drops of up to 0.25V per wire. The unit will NOT operate if there are no connections between the sense and output terminals. Connections must be made at the load or at the power supply terminals.

NOTE: If long sense wires are used it is recommended to place a 100 μ F (or more) electrolytic capacitor between the (+) and (+S) terminals and between the (-) and (-S) terminals to reduce possible oscillations of the output voltage (see Figure 5).

VIII OUTPUT VOLTAGE CONTROL

Terminals (RV1) and (RV2) are provided for the addition of fixed and trimmer resistors to permit control of the output voltage within the published specifications.

OUTPUT VOLTAGE	5V	12V	15V	24V
TRIMMER RESISTOR	10K	10K	10K	10K
FIXED RESISTOR	2.2K ohms	5.6K	15K	39K

NOTE: For a fixed output voltage (see Figure 5) do not connect any resistors to the (RV1) and (RV2) terminals.

IX FOR SINGLE POWER SUPPLY OPERATION

For single power supply operation connect the Overcurrent Sense terminal (OC1) to the Common terminal (COM) (see Figure 9). In this configuration, the maximum output current and power is delivered to the load.

X PARALLEL OPERATION

Parallel operation is available to increase the output current. For parallel operation open the connection between the Common terminal (COM) and the Overcurrent Sense terminal (OC1)

(see Figure 10). The output power of each power supply will then be 80 percent of the maximum rated power. To get a balanced output current from each power supply (in parallel operation) the user must check to ensure that the difference in output voltages are limited to 1 percent of maximum for each power supply (see Figure 10)

XI SERIES OPERATION

Series operation is available to increase the output voltage. In series operation the output current is limited to the power supply with the lowest rated current (See Figure 11).

XII POLARITY OF INPUT POWER

The power supply has no built-in protection circuit against reverse connection of the (+) and (-) input terminals. The following circuit is recommended (with a diode and fuse on the input terminals) for protection against a reverse polarity connection (see Figure 12).

XIII CONNECTION OF OTHER TERMINALS

The (OC2) terminal and the GATE terminal must remain open. Do not connect any signals to these terminals. If signals are connected to the terminals the power supply will not work correctly and may be subject to electrical damage.

Non-isolated remote ON/OFF circuits are not recommended. Such circuits may short portions of the EMI input filter circuit, making it non-operational. Also, large currents may return to the minus input terminal (-) via the Common terminal (COM), resulting in damage to the PC Board Foil.

XIV AVOID EXTRA OSCILLATIONS

If the input or output cables to the power supply are too long, the output voltage waveforms may show extra oscillations attributable to line inductance or noise.

In that case, placing a 100–470 μ F capacitor between the input terminals or between the output terminals (or at both sets of terminals) will reduce the oscillations.

XV HEAT SINKS

Kepeco recommends the use of a heat sink with the FPD 50 Watt Power Supply. The performance of the Power Supply is improved with a heat sink (see Figures 7A and 7B). Two heat sinks are available, depending on how the FPD 50 Watt Power Supply is mounted (see Figures 8A and 8B).

REVISIONS	
NO.	DESCRIPTION

DRAWN BY		CHECKED BY		APPROVED BY	
DATE		DATE		DATE	

NO.	ITEM	QTY.	MATERIAL DESCRIPTION
4	TERMINAL	8	COPPER ALLOY, 0.03(0.7) DIA., SOLDER PLATED
3	TERMINAL	6	COPPER ALLOY, 0.01(0.3) THICK, SOLDER PLATED
2	COVER	1	HEAT-RESISTANT RESIN
1	HEAT SINK	1	ALUMINUM

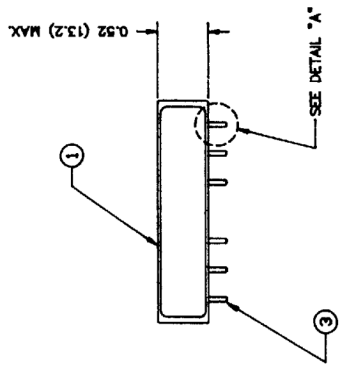
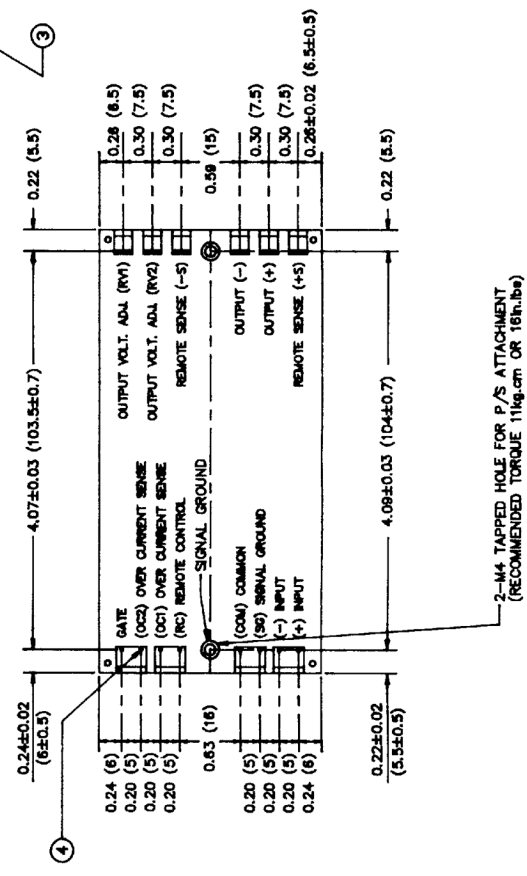
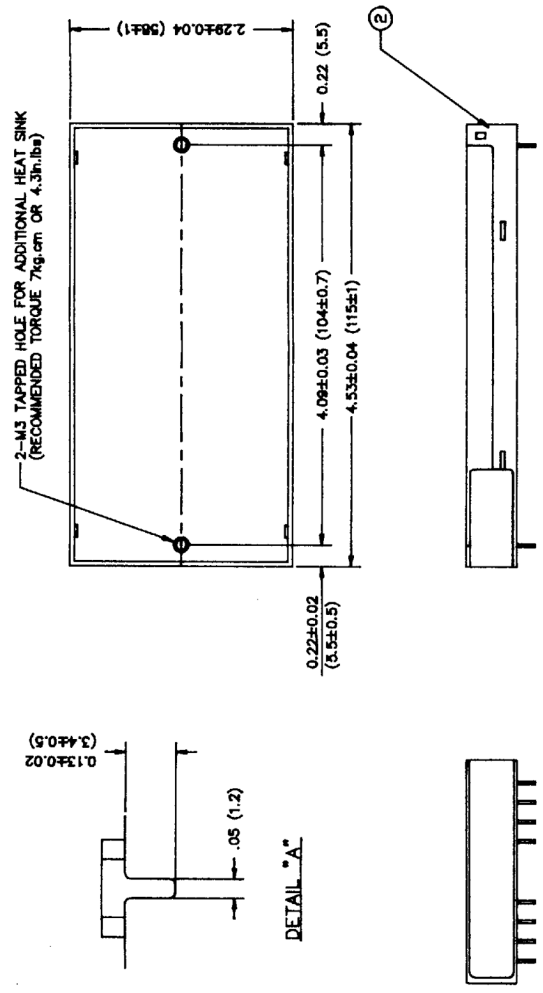

- NOTES:
- THIS DRAWING USED FOR THE FOLLOWING MODELS:
FPD 50-12, -24, -48; FPD 100-24, -48
 - DIMENSIONS IN PARENTHESIS ARE IN MILLIMETERS, ALL OTHERS ARE IN INCHES.
 - MAXIMUM PENETRATION FOR SCREWS FOR M3 AND M4 MOUNTING HOLES NOT TO BE MORE THAN 0.24in (6mm) FROM CASE SURFACE.
 - ±0.01in. (±0.3mm) TOLERANCE UNLESS OTHERWISE SPECIFIED.
 - KEPCO SUPPLIES THE FOLLOWING HARDWARE FOR FPD METRIC INSERTS:
TWO METRIC M3 SCREWS WITH CAPTIVE FLAT AND LOCK WASHERS P/N 501-0062.
TWO METRIC M4 SCREWS WITH CAPTIVE FLAT AND LOCK WASHERS P/N 501-0035.
TWO NYLON WASHERS (FOR INSULATION) P/N 103-0144.

TOLERANCES UNLESS OTHERWISE SPECIFIED		DRAWN BY	DATE
FRACTIONS	3/16	PAD	5-3-90
DECIMALS	0.001	CHECKED BY	DATE
ANGLES	1/16	REC	9-28-90
MATERIAL	AS SHOWN	DESIGNED BY	DATE
FINISH	AS SHOWN	REC	9-28-90
APPROVED BY	DATE	APPROVED BY	DATE
K.K.	9-28-90	K.K.	9-28-90

KEPCO
Parsippany, N.J. USA

MODEL NO. SEE NOTE #1
PART NO. SCALE
SHEET NO. CF04183

OUTLINE DRAWING

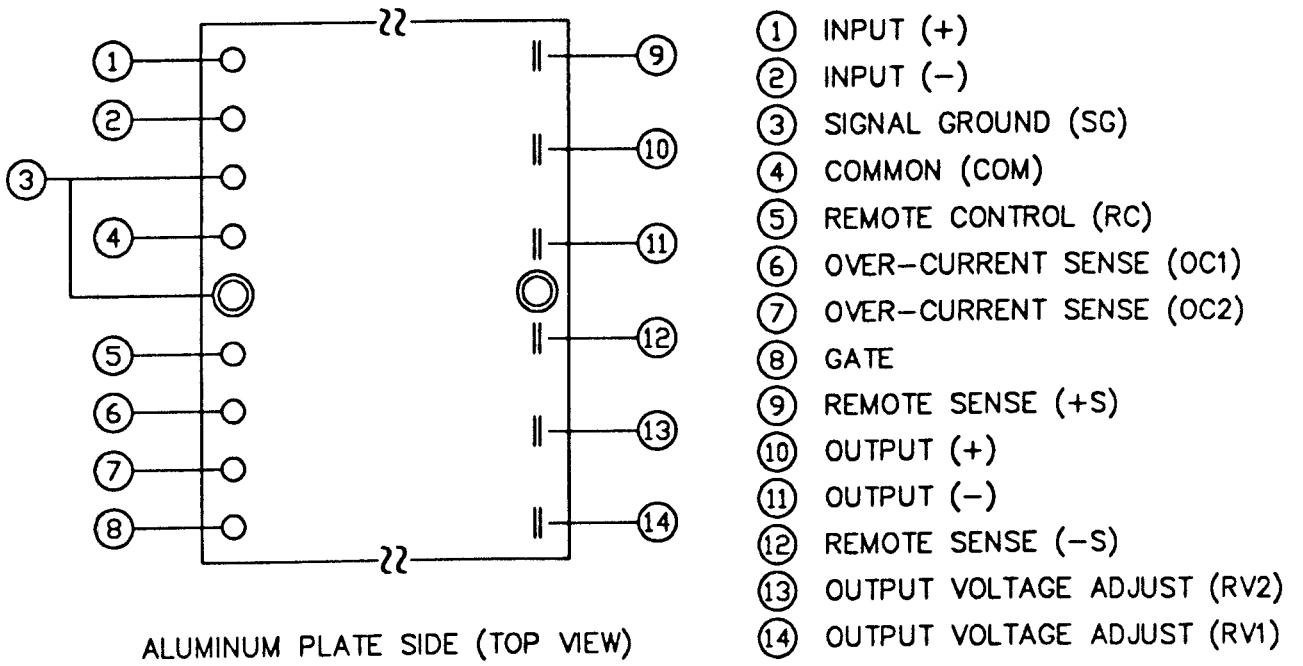

FIGURE 2 TERMINAL LOCATIONS OF THE FPD 50-12 DC TO DC CONVERTER, ALUMINUM PLATE SIDE (TOP VIEW)

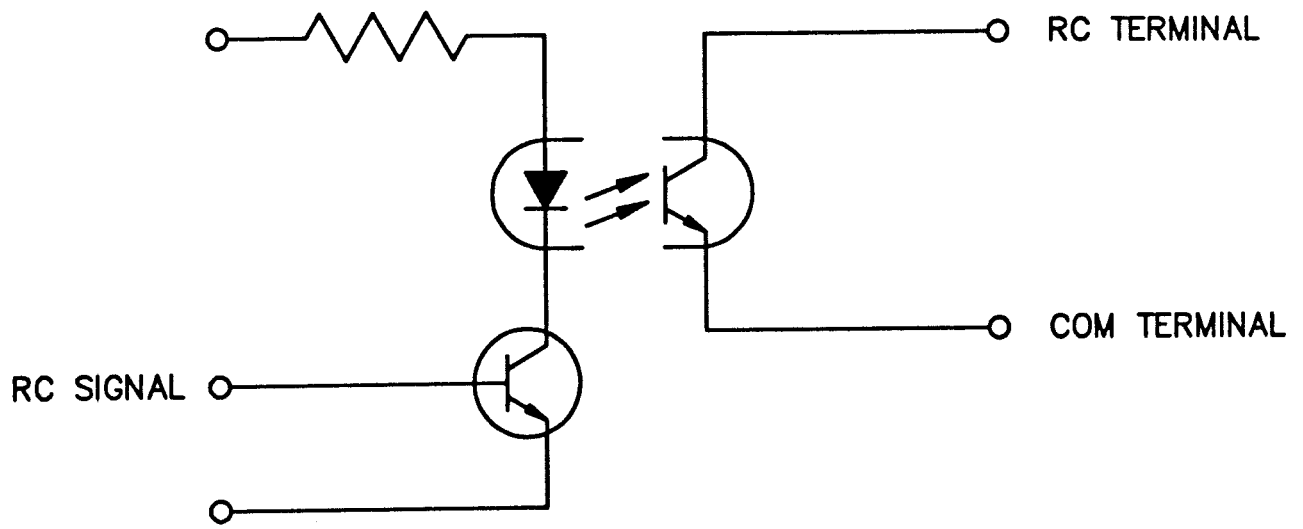

FIGURE 3 RECOMMENDED REMOTE ON/OFF INPUT CIRCUIT TO THE RC TERMINAL OF THE FPD 50-12 POWER SUPPLY

OUTPUT CHARACTERISTIC

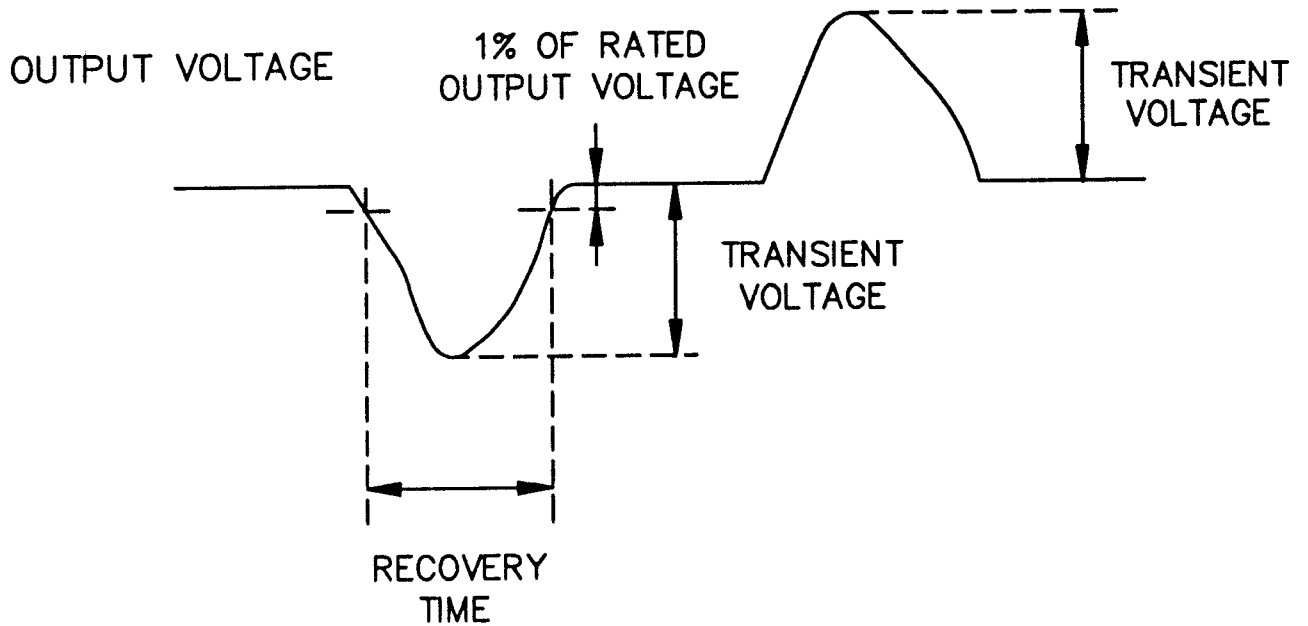
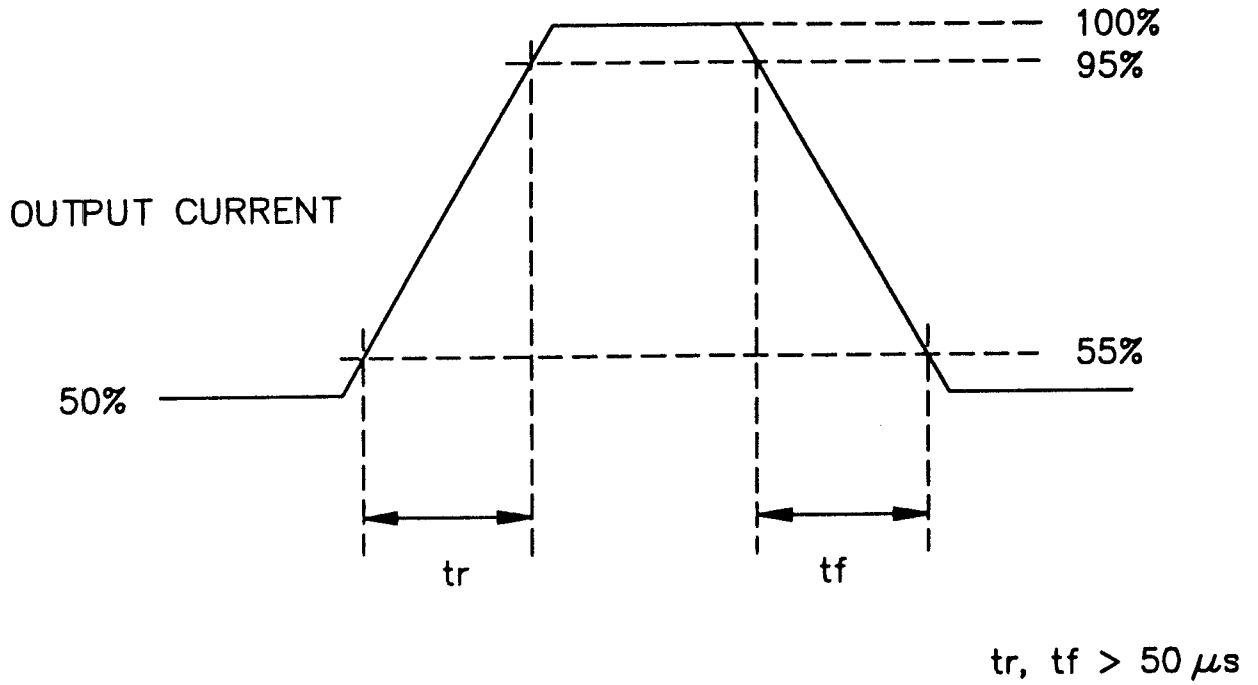

FIGURE 4 THE RECOVERY CHARACTERISTICS OF THE FPD 50-12 POWER SUPPLY

NOTE: To further reduce the transient voltage place a capacitor between the (+) and (-) output terminals of the Power Supply, preferably close to the load.

(OUTPUT VOLTAGE FIXED)

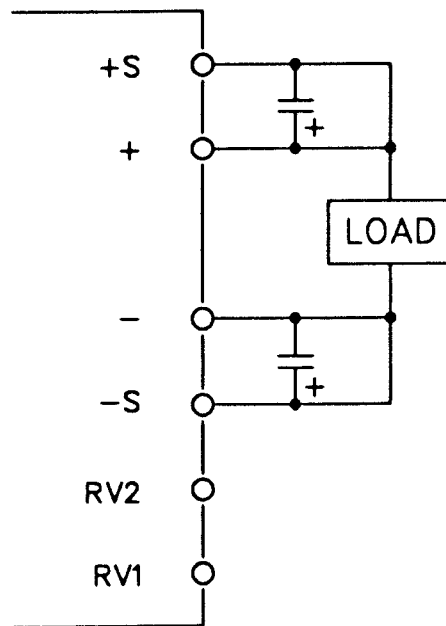

FIGURE 5 THE FPD 50-12 DC TO DC CONVERTER WITH REMOTE SENSING AND FIXED OUTPUT VOLTAGE

(OUTPUT VOLTAGE ADJUSTABLE)

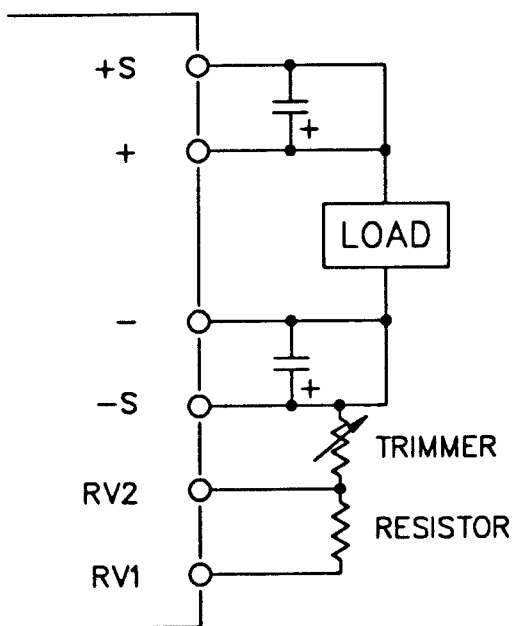

FIGURE 6 THE FPD 50-12 DC TO DC CONVERTER WITH ADJUSTABLE OUTPUT VOLTAGE

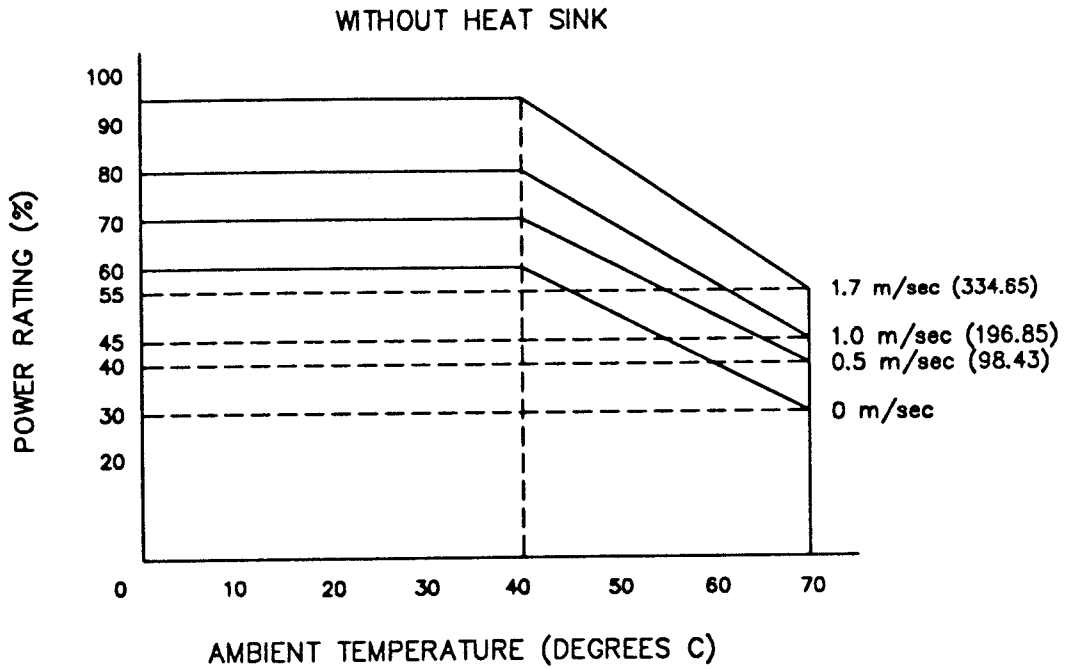
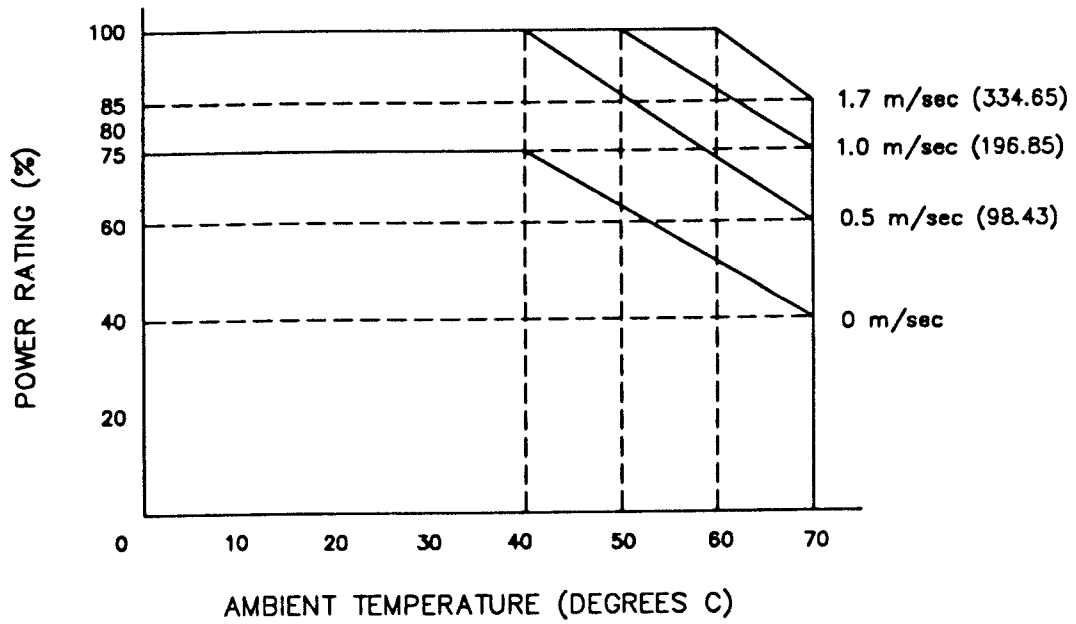

FIGURE 7A (ABOVE) PERCENT OUTPUT POWER RATING VERSUS AMBIENT TEMPERATURE DEGREES C FOR THE FPD 50-12 DC TO DC CONVERTER WITH HEAT SINK

NOTE: The maximum temperature on the power supply base plate (aluminum plate) is 85°C. Dimensions in parenthesis are in linear ft/min.

FIGURE 7B (BELOW) PERCENT OUTPUT POWER RATING VERSUS AMBIENT TEMPERATURE DEGREES C FOR FPD 50-12 DC TO DC CONVERTER WITHOUT HEAT SINK

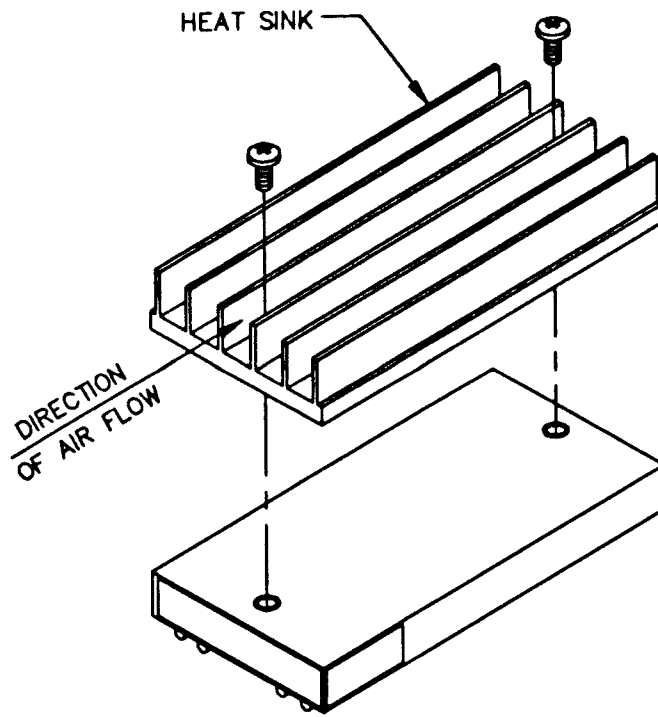

FIGURE 8A HEAT SINK FOR VERTICAL MOUNTING OF THE FPD 50-12 DC TO DC CONVERTER

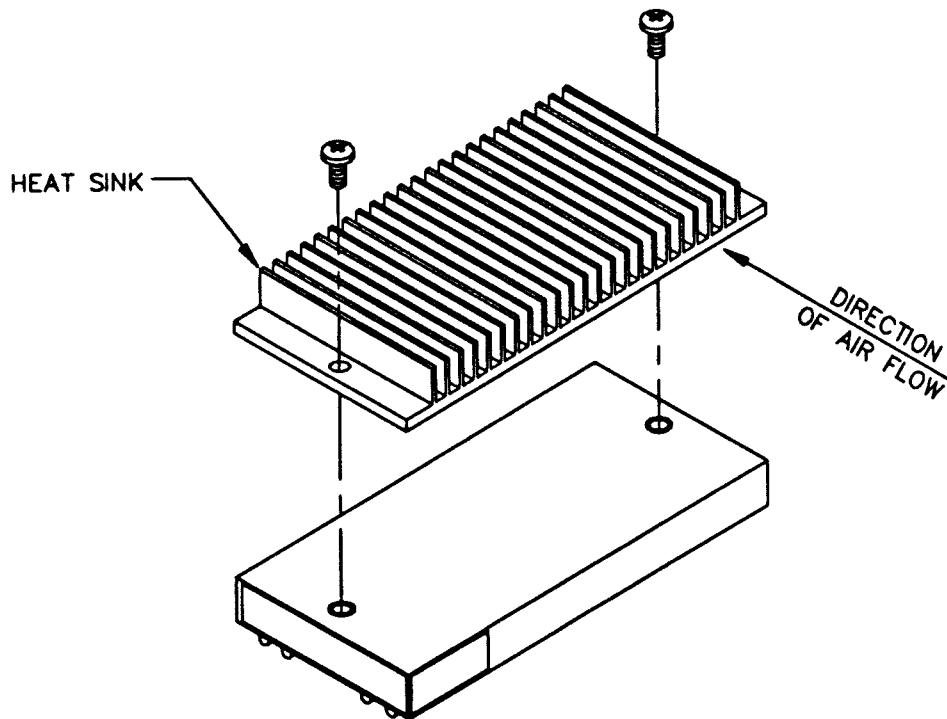

FIGURE 8B HEAT SINK FOR HORIZONTAL MOUNTING OF THE FPD 50-12 DC TO DC CONVERTER

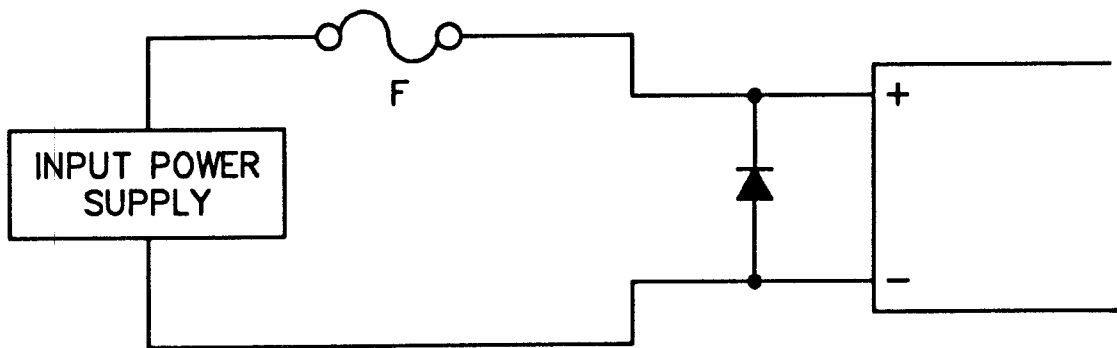
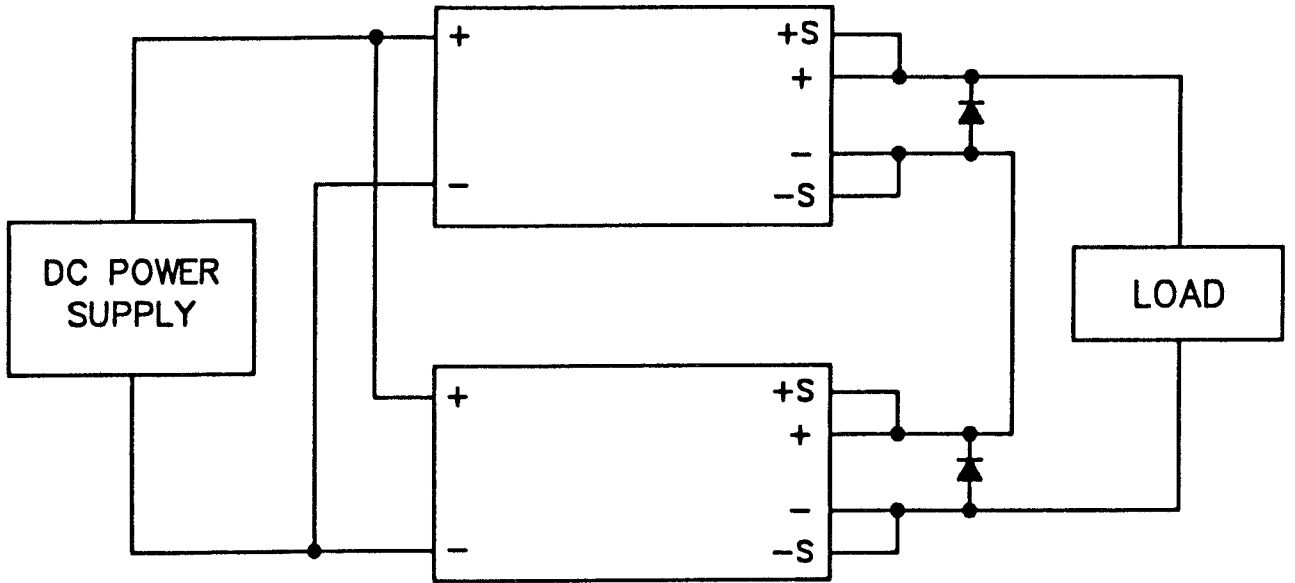

FIGURE 11 (ABOVE) CONNECTION FOR SERIES OPERATION OF THE FPD 50-12 POWER SUPPLY

FIGURE 12 (BELOW) PROTECTION CIRCUIT FOR REVERSE POLARITY CONNECTION TO THE FPD 50-12 POWER SUPPLY

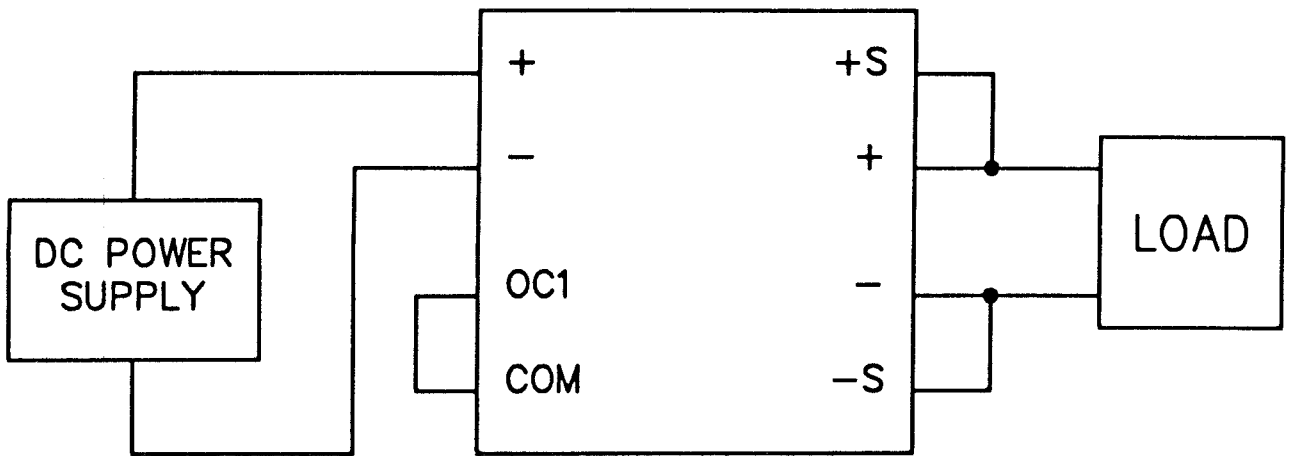

FIGURE 9 CONNECTION FOR SINGLE FPD 50-12 POWER SUPPLY OPERATION

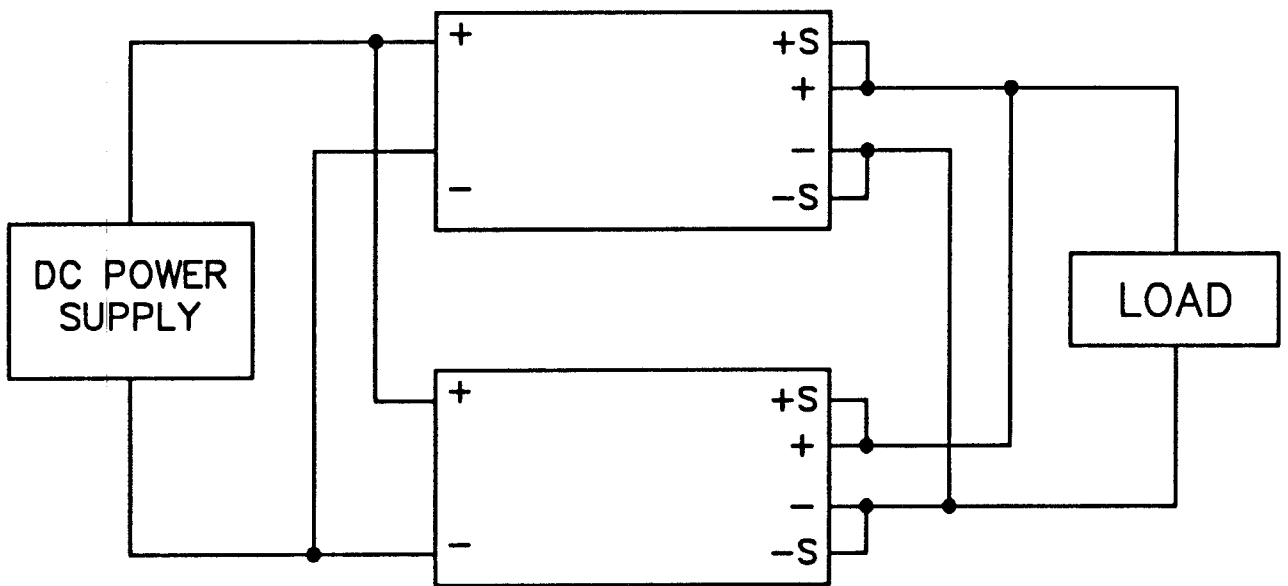

FIGURE 10 CONNECTION FOR PARALLEL OPERATION OF THE FPD 50-12 POWER SUPPLY

You must register your product to comply with the terms of the warranty. Either fill out the form below and mail or fax to Kepco, or for rapid on-line registration go to:

<http://www.kepcopower.com/warranty.htm>

PRODUCT PURCHASED:

Model Number) _____

Serial Number _____

PURCHASE INFORMATION:

Date Purchased: _____

Date Received: _____

REQUEST ADDITIONAL INFORMATION

Send complete Catalog

Have Sales Engineer Call

Contact via: E-Mail Telephone Fax S-mail

REGISTER TO:

Registered by: _____

Company Name: _____

Street: _____

City: _____

State: _____

Country: _____

Zip: _____

E-mail: _____

FAX: _____

Phone: _____

WHAT INFLUENCED YOUR CHOICE OF THIS POWER SUPPLY?

Previous Experience (which Kepco Models do you have?) _____

Magazines (which ones?) _____

Trade Shows (which ones?) _____

Directory? _____

Kepco Catalog or Brochure? _____

Sales Representative?

Web Site

Other (please explain): _____

What products would you like to see Kepco make?

CUT HERE

Kepco 1 Year Warranty

This is to certify that we, KEPCO, INC., (hereinafter called "Company"), Flushing, NY 11355 USA, warrants for a period of ONE YEAR, this instrument known as:

MODEL: _____

SERIAL NO. _____

The Company's products are warranted for a period of one year from date of delivery to be free from defects in materials and workmanship and to conform to the specifications furnished or approved by the Company. Liability under this warranty shall be limited to the repair or replacement of any defective product at Company's option.

If any defect within this warranty appears within the warranty period, the Purchaser shall promptly notify the Company in writing. No material will be accepted for repair or replacement without written authorization of the Company.

Upon such authorization, and in accordance with instructions of the Company, parts or materials for which replacement is requested shall be returned to the Company for examination, with shipping charges prepaid by the Purchaser. Final determination as to whether a product is actually defective rests with the Company.

This warranty does not extend to any product which has been subjected to misuse, neglect, accident, improper installation, or use in violation of instructions furnished by the Company. The warranty does not extend to, or apply to, any unit which has been repaired or altered outside of the Company's factory by persons not expressly approved by the Company.

THE WARRANTY HEREIN CONTAINED IS IN LIEU OF AND EXCLUDES ALL OTHER WARRANTIES, EXPRESS, IMPLIED OR STATUTORY, INCLUDING WITHOUT LIMITATION THE WARRANTY OF MERCHANTABILITY.

THIS KEPCO PRODUCT IS WARRANTED FOR ONE YEAR!

KEPCO, INC. • 131-38 SANFORD AVENUE, FLUSHING, NY 11355 USA • Tel. 718-461-7000 • Fax. 718-767-1102
E-mail: hq@kepcopower.com • URL: <http://www.kepcopower.com>



FOLD HERE

Please
place
stamp
here

KEPCO, INC.

131-38 SANFORD AVE.
FLUSHING, NY 11355 USA

CUT HERE