

INSTRUCTION MANUAL



KEPCO An ISO 9001 Company.

**KIT
DIN AK
-150/200S**

DIN-RAIL MOUNTING KIT FOR SERIES AK-150S, AK-200S

DESCRIPTION. Kepco KITS, Models DIN AK-150S and AK-200S each contain two preassembled mounting clips and associated hardware used to install AK-150 and AK-200 Series power supplies on a DIN rail. The "S" suffix is for mounting horizontally along the short dimension (width) as shown in Figure 1. Outline dimensions are shown in Figure 4.

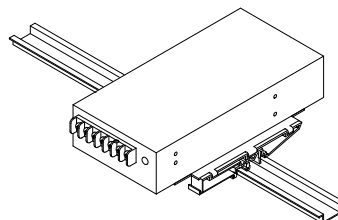

3043979

FIGURE 1. S SUFFIX ORIENTATION

TABLE 1. COMPONENTS SUPPLIED

KIT MODEL NO.	MOUNTING PLATE (QTY 1) PART NO.	CLIP (QTY 2) PART NO.	SCREW, SEMS (QTY 2) PART NO.	LOCK-WASHER (QTY 2) PART NO.	FLAT WASHER (QTY 2) PART NO.	NUT (QTY 2) PART NO.	SCREW (QTY 2) PART NO.
DIN AK-150S, DIN AK-200S	128-2449	108-0362	101-0463 (M4 X 8 PHPH)	103-0015 (NO. 6, Int. Tooth)	103-0028 (NO. 6)	102-0004 (Hex, 1/4" x 6-32)	101-0408 (FH 6-32 x 5/16")

INSTALLING KIT. Attach the preassembled mounting clips to the power supply using the hardware supplied (see Figure 3). The clips may be mounted with the release lever on either side to facilitate removal.

INSTALLING POWER SUPPLY ON DIN RAIL. To mount the power supply on the rail insert one end of both clips under one edge of the rail, then snap the other end of the two clips into place (see Figure 2A). If the DIN rail is mounted on a flat surface, the DIN rail must be raised at least 0.86 in. above flat surface to avoid interference during installation/removal.

REMOVING POWER SUPPLY FROM DIN RAIL. While grasping the power supply with one hand, use a screwdriver to apply leverage towards the right as shown in Figure 2B to disengage each clip from the rail. Where mounting clips are close together, it may be necessary to apply leverage with two screwdrivers simultaneously.

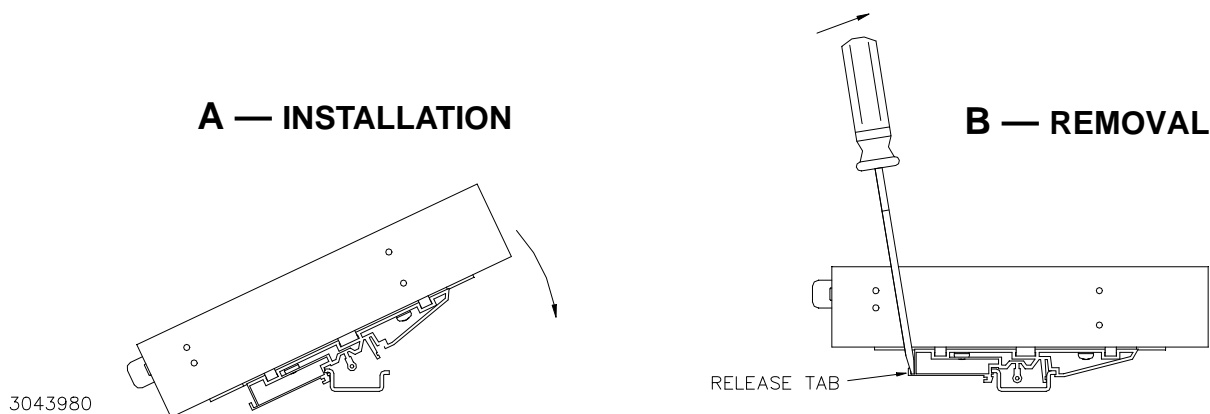

FIGURE 2. INSTALLATION AND REMOVAL OF POWER SUPPLY FROM DIN RAIL

KEPCO, INC. ● 131-38 SANFORD AVENUE ● FLUSHING, NY. 11355 U.S.A. ● TEL (718) 461-7000 ● FAX (718) 767-1102
http://www.kepcopower.com ● email: hq@kepcopower.com

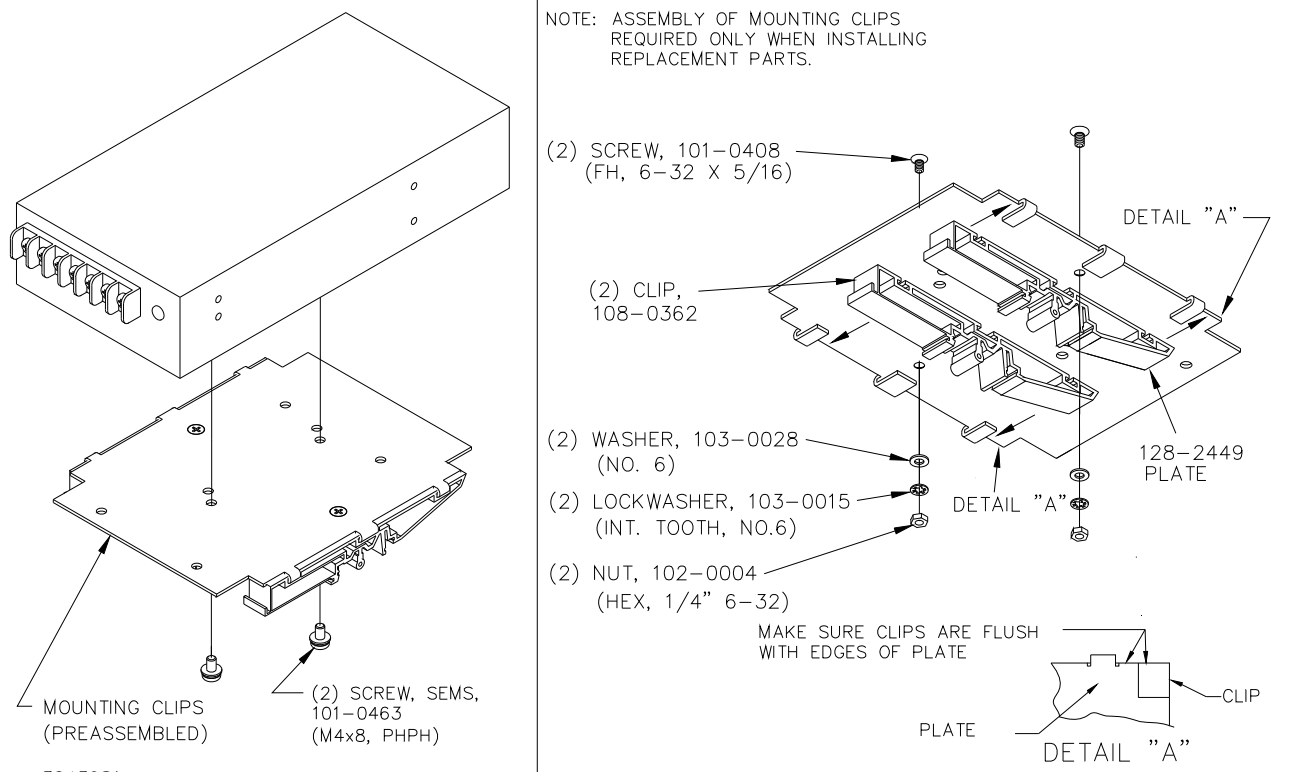

FIGURE 3. INSTALLATION OF KIT ON POWER SUPPLY

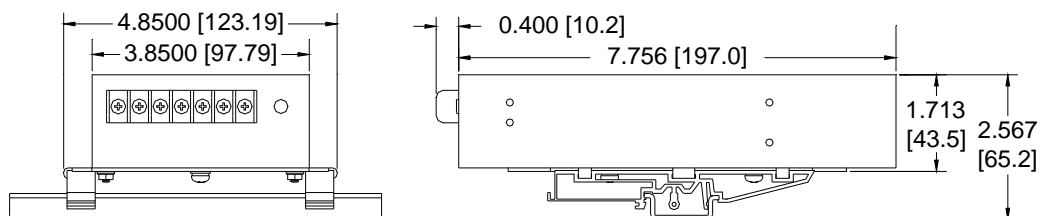

FIGURE 4. POWER SUPPLY WITH KIT INSTALLED, OUTLINE DIMENSIONS