

INSTRUCTION MANUAL



KEPCO An ISO 9001 Company.

**KIT
DIN RKW-600P**

DIN-RAIL MOUNTING KIT FOR SERIES RKW 600W

DESCRIPTION. Kepco Kit, Model DIN RKW-600P, contains a preassembled mounting plate and associated hardware used to install RKW 600 Watt Series power supplies on a DIN rail. The "P" suffix is for mounting perpendicular to the long dimension (length) as shown in Figure 1. Outline dimensions are shown in Figure 4.

3042417

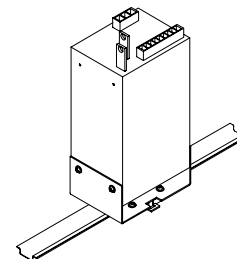

FIGURE 1. P SUFFIX ORIENTATION

INSTALLING KIT. Attach the preassembled mounting plate to the power supply using the hardware supplied (see Figure 3). The plate may be mounted with the release lever on either side to facilitate removal.

INSTALLING POWER SUPPLY ON DIN RAIL. To mount the power supply on the rail insert one end of the clip under one edge of the rail, then snap the other end of the clip into place (see Figure 2A).

NOTE: For applications where the installed power supply may be subject to unusual levels of shock or vibration, the use of two DIN rail end stops (Kepco P/N 108-0367) is recommended. After installing the power supply on the rail, the end stops are installed by clearing the DIN rail of other components and sliding the end stops over the rail. When the end stops are secure against the power supply, tighten the two integral screws of each end stop.

REMOVING POWER SUPPLY FROM DIN RAIL. While grasping the power supply with one hand, use a screwdriver to apply leverage towards the left as shown in Figure 2B to disengage the clip from the rail.

A - INSTALLATION

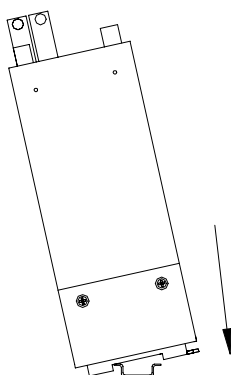

3042418

B - REMOVAL

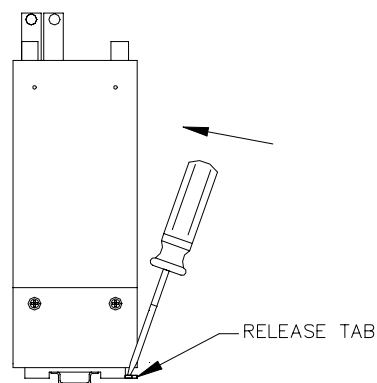
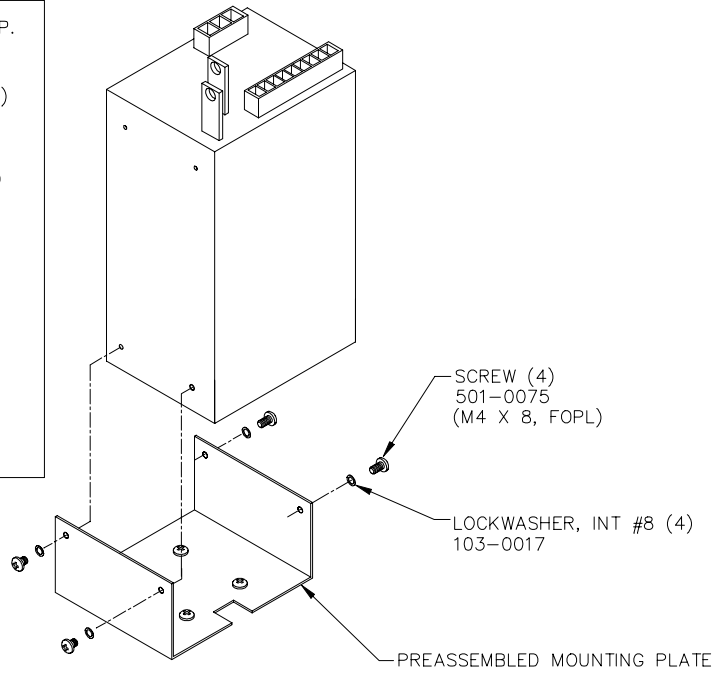
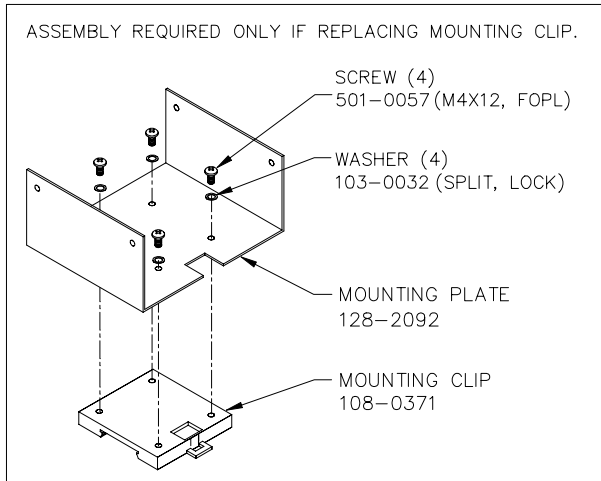
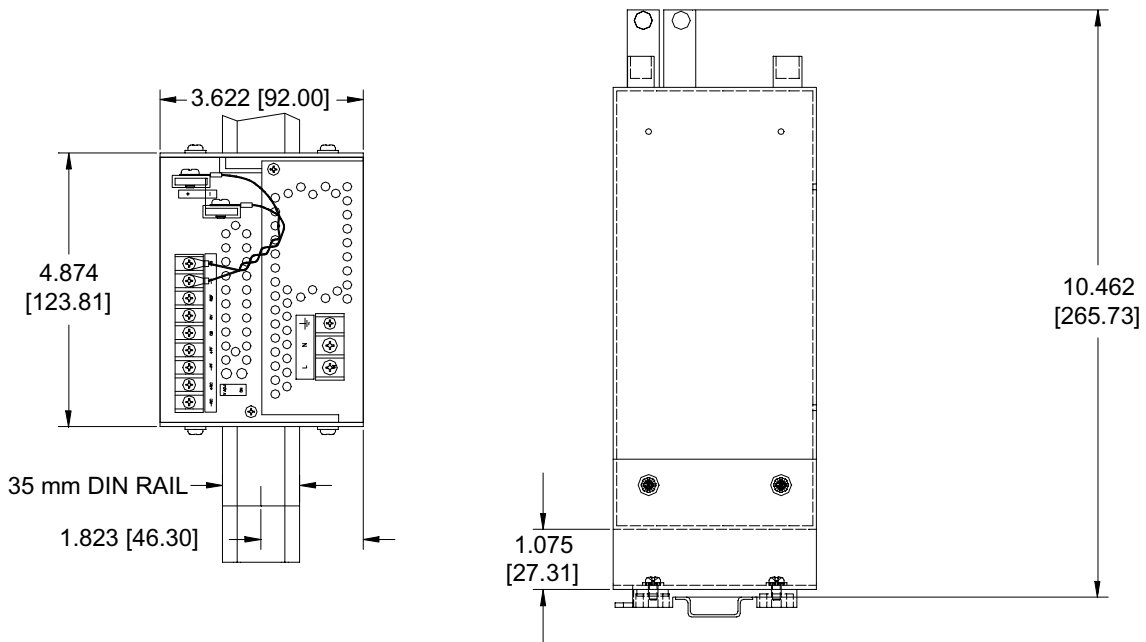

FIGURE 2. INSTALLATION AND REMOVAL OF POWER SUPPLY FROM DIN RAIL



3042419

FIGURE 3. INSTALLATION OF KIT ON RKW 600W POWER SUPPLY



3042420

NOTE: DIMENSIONS ARE IN INCHES. DIMENSIONS IN BRACKETS ARE IN MILLIMETERS.

FIGURE 4. RKW 600W POWER SUPPLY WITH KIT INSTALLED, OUTLINE DIMENSIONS