

INSTRUCTION MANUAL



KEPCO An ISO 9001 Company.

**KIT
DIN ERX
-60L**

DIN-RAIL MOUNTING KIT FOR SERIES ERX 60W

DESCRIPTION. Kepco KIT, Model DIN ERX-60L contains a cover, cable kit, left and right mounting clips, and associated hardware (see Table 1) used to install ERX Series 60W power supplies on a DIN rail. The "L" suffix is for mounting along the long dimension (length) as shown in Figure 1. Outline dimensions are shown in Figure 4.

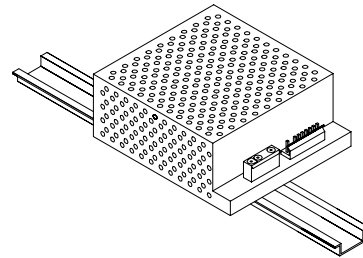

3041827

FIGURE 1. L SUFFIX ORIENTATION

TABLE 1. COMPONENTS SUPPLIED

KIT MODEL NO.	COVER PART NO.	CABLE KIT PART NO.	CLIP (QTY 2) PART NO.	BRACKET (QTY 2) PART NO.	SCREW (QTY 4) PART NO.	WASHER (QTY4) PART NO.
DIN ERX-60L	CA 16	518-0006 518-0008	108-0362	128-1989	101-0383 (8-32 X 0.187 PHPH)	103-0017 (NO. 8, INT. TOOTH)

NOTE: Clip and Bracket are supplied preassembled into left and right mounting clip assemblies. To replace a mounting clip assembly, order both the clip and bracket and assemble per Figure 2 detail.

INSTALLATION

- INSTALL COVER.** Attach the cover to the power supply per Instruction Manual supplied with the cover.
- INSTALL CLIPS.** Attach left and right clips to power supply using hardware supplied (see Figure 2).

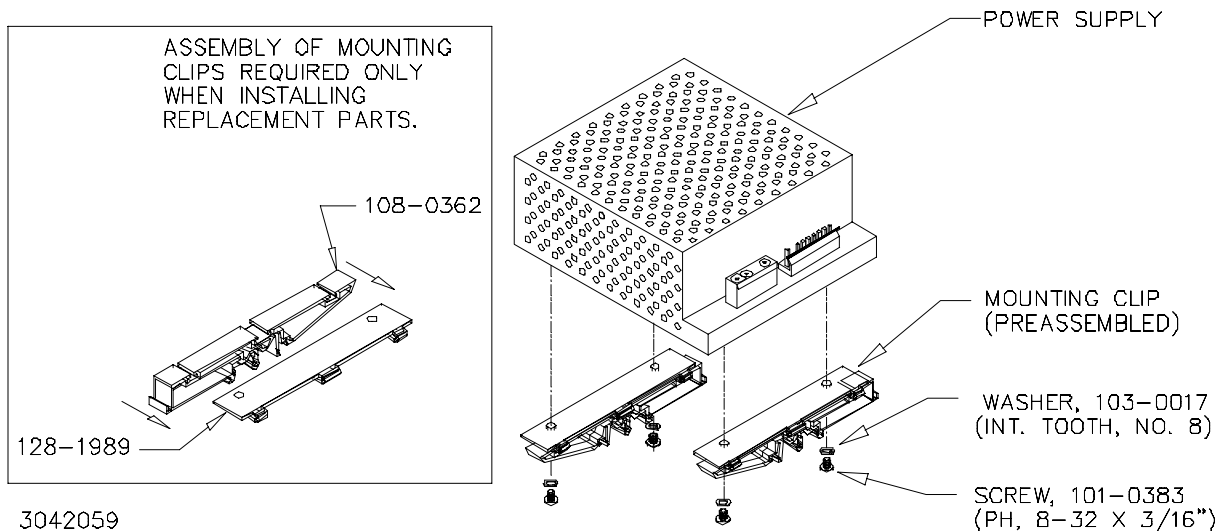

FIGURE 2. INSTALLING CLIPS ON POWER SUPPLY

KEPCO, INC. ● 131-38 SANFORD AVENUE ● FLUSHING, NY. 11352 U.S.A. ● TEL (718) 461-7000 ● FAX (718) 767-1102
<http://www.kepcopower.com> ● email: hq@kepcopower.com

3. **INSTALL CABLE KIT.** Attach wires to the power supply per Instruction Sheet supplied with cable kit.
4. **INSTALL POWER SUPPLY ON DIN RAIL.** To mount the power supply on the rail insert one end of both clips under one edge of the rail, then snap the other end of the two clips into place (see Figure 3A).

REMOVING POWER SUPPLY FROM DIN RAIL. With power off, disconnect wires from power supply. While grasping the power supply with one hand, insert a screwdriver in the area shown in Figure 3B and apply leverage towards the left as shown in Figure 3B to disengage each clip from the rail. Where mounting clips are close together, it may be necessary to apply leverage with two screwdrivers simultaneously.

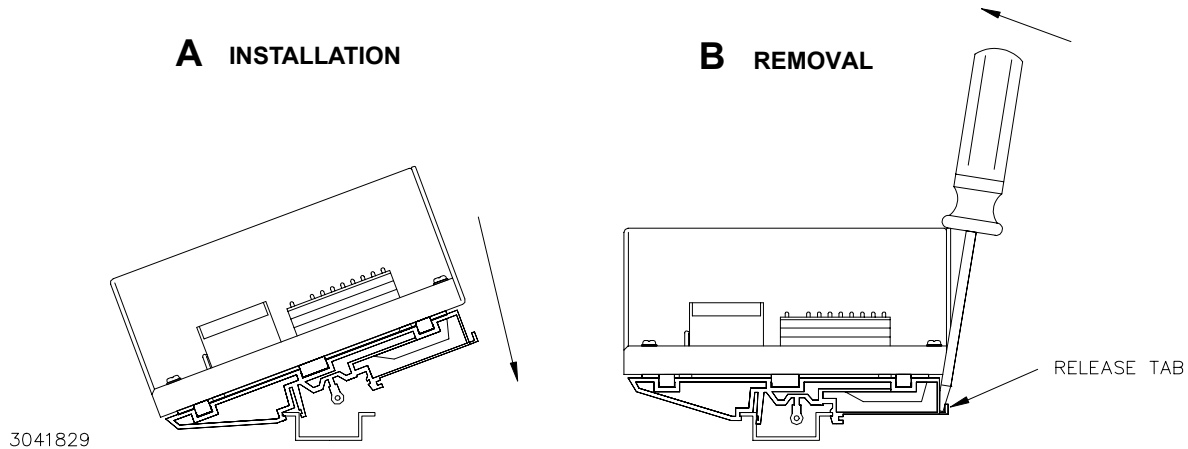
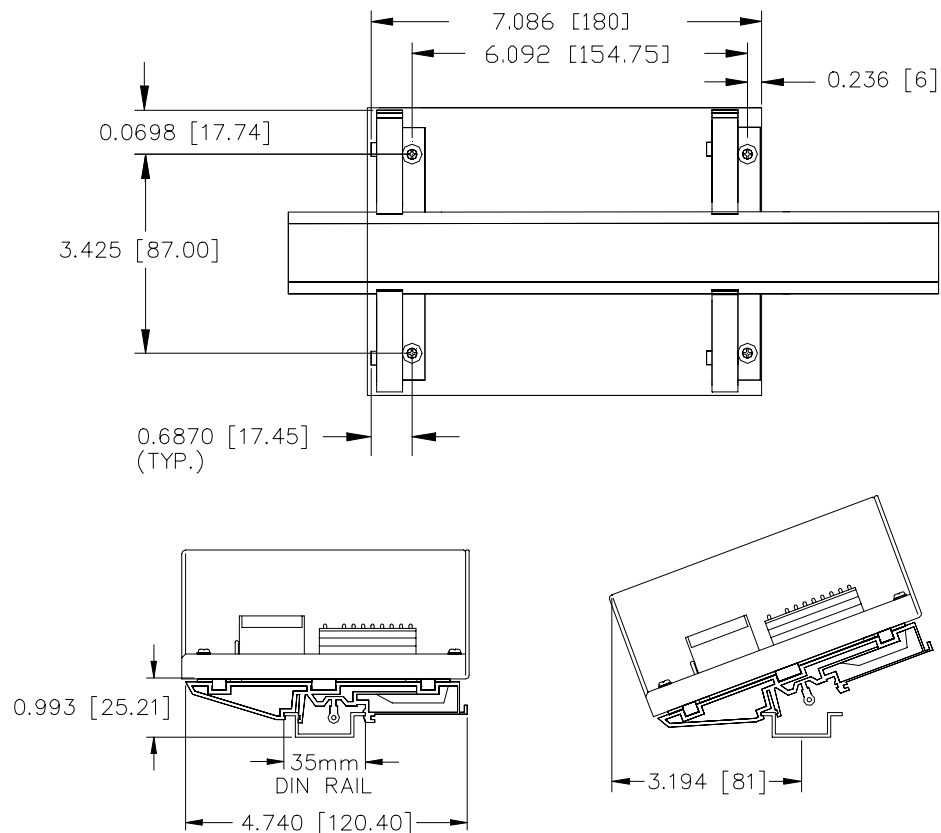

FIGURE 3. INSTALLATION AND REMOVAL OF POWER SUPPLY FROM DIN RAIL



3042060

NOTE: DIMENSIONS ARE IN INCHES; DIMENSIONS IN BRACKETS ARE IN MILLIMETERS.

FIGURE 4. POWER SUPPLY WITH KIT INSTALLED, OUTLINE DIMENSIONS