

# INSTRUCTION MANUAL



**KEPCO** An ISO 9001 Company.

**KIT  
DIN RCW  
-175S**

## DIN-RAIL MOUNTING KIT FOR SERIES RCW 175W

**DESCRIPTION.** Kepco KIT, Model DIN RCW-175S, contains two preassembled mounting clips and associated hardware used to install RCW 175 Watt Series power supplies on a DIN rail. The "S" suffix is for mounting along the short dimension (width) as shown in Figure 1. Outline dimensions are shown in Figure 4.

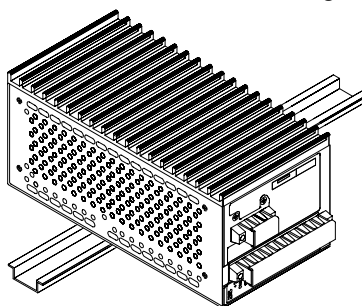

3041781

**FIGURE 1. S SUFFIX ORIENTATION**

**INSTALLING KIT.** Attach the preassembled mounting clips to the power supply using the hardware supplied (see Figure 3). The clips may be mounted with the release lever on either side to facilitate removal.

**INSTALLING POWER SUPPLY ON DIN RAIL.** To mount the power supply on the rail insert one end of both clips under one edge of the rail, then snap the other end of the two clips into place (see Figure 2A).

**REMOVING POWER SUPPLY FROM DIN RAIL.** While grasping the power supply with one hand, use a screwdriver to apply leverage towards the left as shown in Figure 2B to disengage each clip from the rail. Where mounting clips are close together, it may be necessary to apply leverage with two screwdrivers simultaneously.

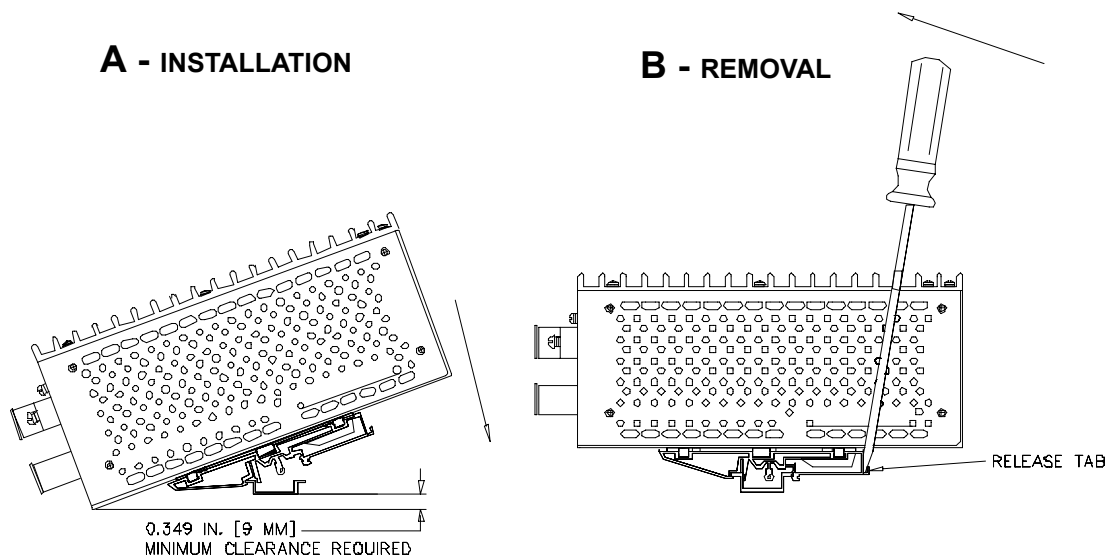

3041782

**FIGURE 2. INSTALLATION AND REMOVAL OF POWER SUPPLY FROM DIN RAIL**

KEPCO, INC. ● 131-38 SANFORD AVENUE ● FLUSHING, NY. 11352 U.S.A. ● TEL (718) 461-7000 ● FAX (718) 767-1102  
<http://www.kepcopower.com> ● email: [hq@kepcopower.com](mailto:hq@kepcopower.com)

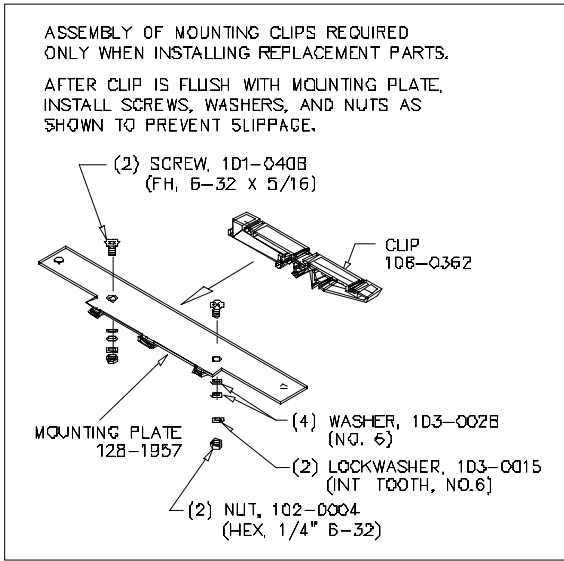

3D41796

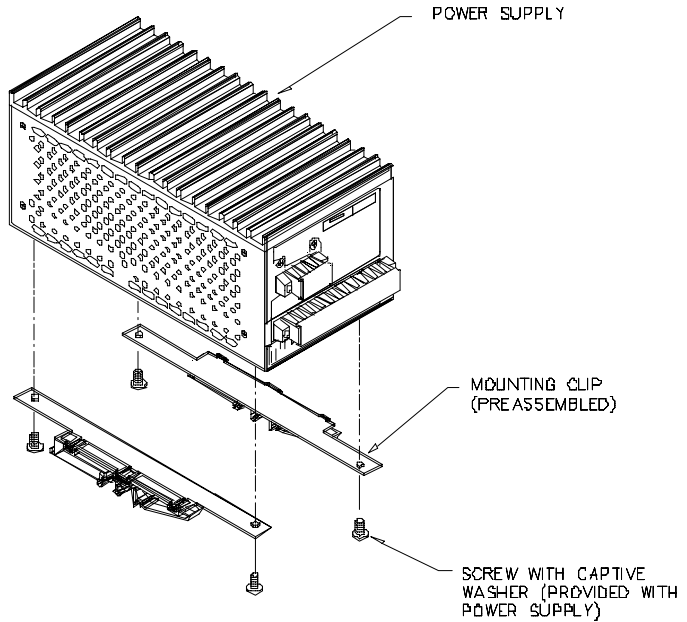
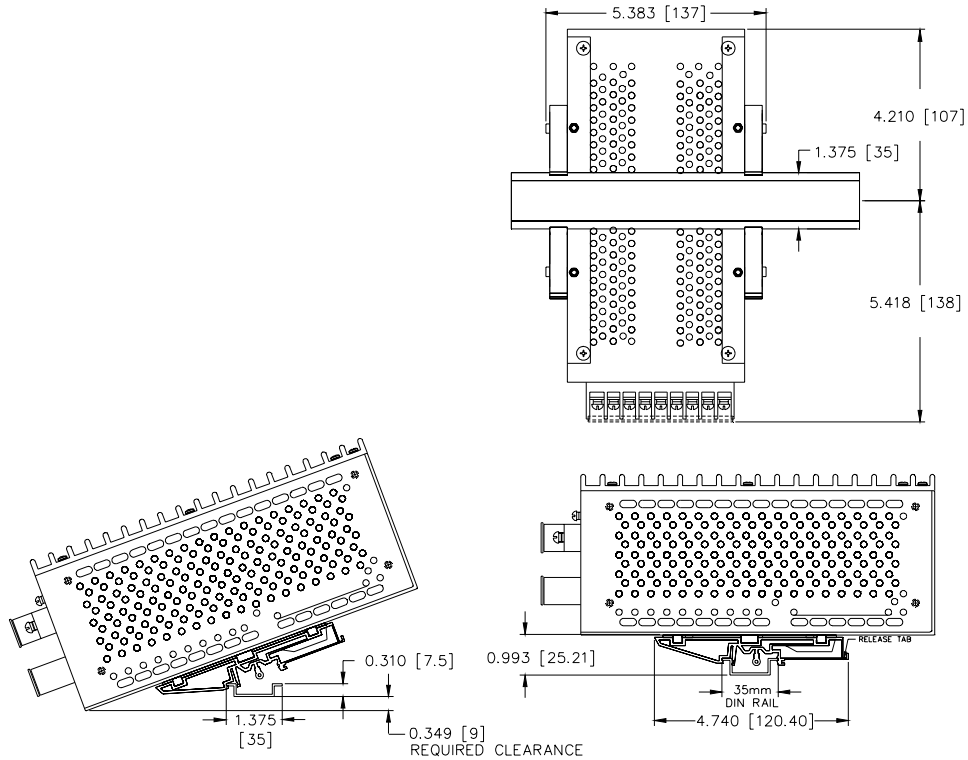

FIGURE 3. INSTALLATION OF KIT ON RCW 175W POWER SUPPLY



3041784

NOTE: DIMENSIONS ARE IN INCHES, DIMENSIONS IN BRACKETS ARE IN MILLIMETERS.

FIGURE 4. RCW 175W POWER SUPPLY WITH KIT INSTALLED, OUTLINE DIMENSIONS